

## High-Performance 8-Bit Single Chip Microcontroller

SAB 80515/80535

### Preliminary

**SAB 80515** Microcontroller with factory mask-programmable ROM

**SAB 80535** Microcontroller for external ROM

- 8 K × 8 ROM (SAB 80C515 only)
- 256 × 8 RAM
- Six 8-bit I/O ports, one 8-bit input port for analog signals
- Three 16-bit timer/counters
- Highly flexible reload, capture, compare capabilities
- Full-duplex serial channel
- Twelve interrupt vectors, four priority levels
- 8-bit A/D converter with 8 multiplexed inputs and programmable internal reference voltages
- 16-bit watchdog timer
- $V_{PD}$  provides standby current for 40 bytes of RAM
- Boolean processor
- 256-bit-addressable locations
- Most instructions execute in 1  $\mu$ s (750 ns)
- 4  $\mu$ s (3  $\mu$ s) multiply and divide
- External memory expandable up to 128 Kbytes
- Backwardly compatible with SAB 8051
- Three temperature ranges available:
  - 0 to 70 °C
  - 40 to 85 °C (T40/85)
  - 40 to 110 °C (T40/110)

The SAB 80515/80535 is a powerful member of the Siemens SAB 8051 family of 8-bit microcontrollers. It is fabricated in + 5 V N-channel, silicon-gate Siemens MYMOS technology. The SAB 80515/80535 is a stand-alone, high-performance single-chip microcontroller based on the SAB 8051 architecture. While maintaining all the SAB 8051 operating characteristics, the SAB 80515/80535 incorporates several enhancements which significantly increase design flexibility and overall system performance.

The SAB 80535 is identical with the SAB 80515 except that it lacks the on-chip program memory. The SAB 80515/80535 is supplied in a 68-pin plastic leaded chip carrier package (P-LCC-68).

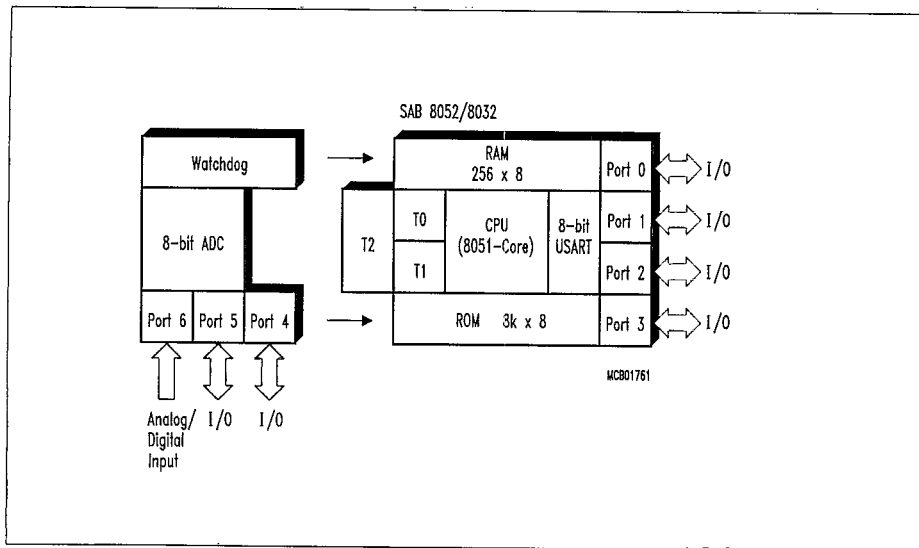

**Ordering Information**

Type	Ordering code	Package	Description 8-bit CMOS microcontroller
SAB 80515-N	Q 67120-C211	P-LCC-68	with mask-programmable ROM
SAB 80535-N	Q 67120-C241	P-LCC-68	for external memory
SAB 80515-N-T40/85	Q 67120-C210	P-LCC-68	with mask-programmable ROM
SAB 80535-N-40/85	Q 67120-C240	P-LCC-68	for external memory

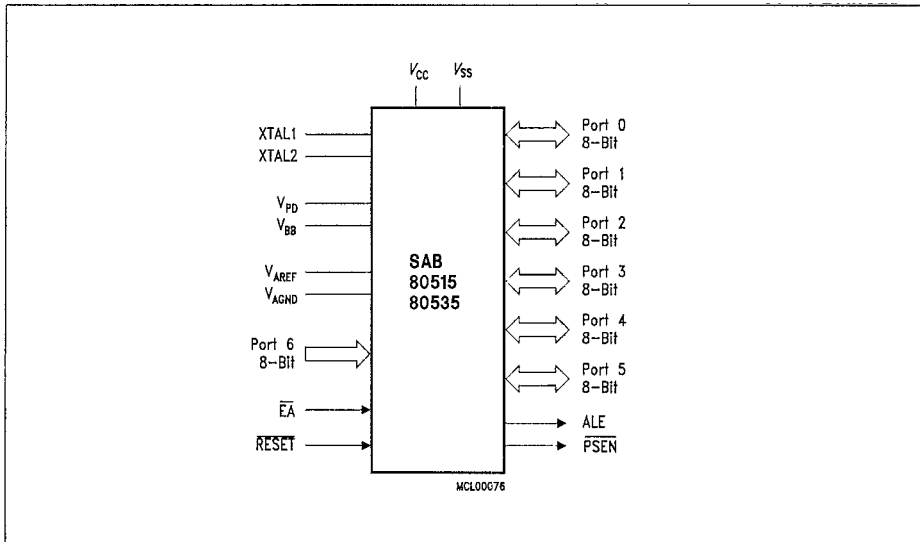

Logic Symbol

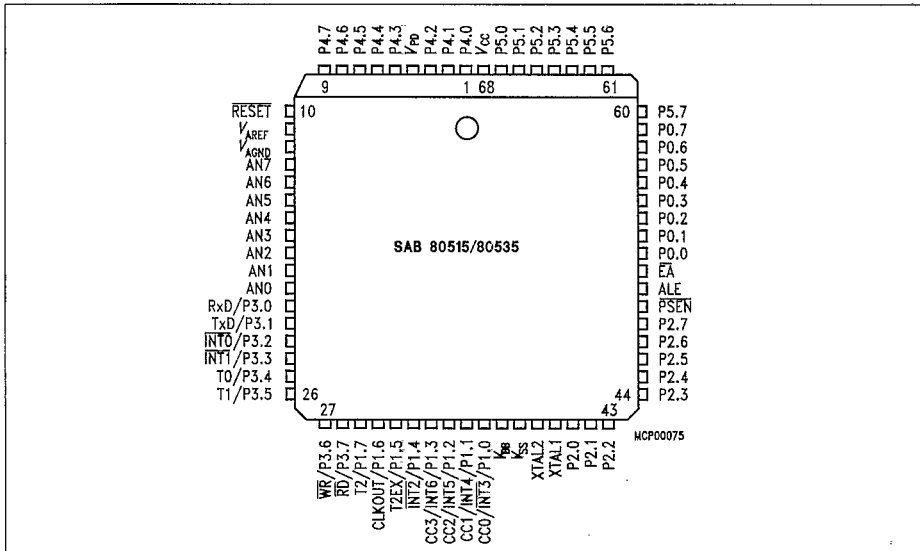

Pin Configuration  
(P-LCC-68)

## Pin Definitions and Functions

Symbol	Pin	Input (I) Output (O)	Function
P4.0-P4.7	1-3, 5-9	I/O	<b>Port 4</b> is an 8-bit quasi-bidirectional I/O port. Port 4 can sink/source 4 LS-TTL loads.
$V_{PD}$	4	I	Power down supply. If $V_{PD}$ is held within its specs while $V_{CC}$ drops below specs, $V_{PD}$ will provide standby power to 40 byte of the internal RAM. When $V_{PD}$ is low, the RAM's current is drawn from $V_{CC}$ .
$\overline{RESET}$	10	I	A low level on this pin for the duration of two machine cycles while the oscillator is running resets the SAB 80C515. A small internal pullup resistor permits power-on reset using only a capacitor connected to $V_{SS}$ .
$V_{AREF}$	11		Reference voltage for the A/D converter
$V_{AGND}$	12		Reference ground for the A/D converter
AN7-AN0	13-20	I	Multiplexed analog inputs

**Pin Definitions and Functions (cont'd)**

Symbol	Pin	Input (I) Output (O)	Function
P3.0-P3.7	21-28	I/O	<p>Port 3 is an 8-bit bidirectional I/O. It also contains the interrupt, timer, serial port and external memory strobe pins that are used by various options. The output latch corresponding to a secondary function must be programmed to a one (1) for that function to operate. Port 3 can sink/source 4 LS-TTL loads. The secondary functions are assigned to the pins of port 3, as follows:</p> <ul style="list-style-type: none"> <li>- R × D (P3.0): serial port's receiver data input (asynchronous) or data input/output (synchronous)</li> <li>- T × D (P3.1): serial port's transmitter data output (asynchronous) or clock output (synchronous)</li> <li>- <math>\overline{\text{INT0}}</math>(P3.2): interrupt 0 input/timer 0 gate control input</li> <li>- <math>\overline{\text{INT1}}</math>(P3.3): interrupt 1 input/timer 1 gate control input</li> <li>- T0 (P3.4): counter 0 input</li> <li>- T1 (P3.5): counter 1 input</li> <li>- <math>\overline{\text{WR}}</math>(P3.6): the write control signal latches the data byte from port 0 into the external data memory</li> <li>- <math>\overline{\text{RD}}</math> (P3.7): the read control signal enables the external data memory to port 0</li> </ul>

**Pin Definitions and Functions (cont'd)**

Symbol	Pin	Input (I) Output (O)	Function
P1.7 - P1.0	29 - 36	I/O	<p>Port 1 is an 8-bit bidirectional I/O port. It is used for the low-order address byte during program verification. It also contains the interrupt, timer, clock, capture and compare pins that are used by various options. The output latch must be programmed to a one (1) for that function to operate (except when used for the compare functions). The secondary functions are assigned to the port 1 pins as follows:</p> <ul style="list-style-type: none"> <li>- <math>\overline{\text{INT3}}/\text{CC0}</math> (P1.0): interrupt 3 input / compare 0 output / capture 0 input</li> <li>- <math>\overline{\text{INT4}}/\text{CC1}</math> (P1.1): interrupt 4 input / compare 1 output / capture 1 input</li> <li>- <math>\overline{\text{INT5}}/\text{CC2}</math> (P1.2): interrupt 5 input / compare 2 output / capture 2 input</li> <li>- <math>\overline{\text{INT6}}/\text{CC3}</math> (P1.3): interrupt 6 input / compare 3 output / capture 3 input</li> <li>- <math>\overline{\text{INT2}}</math>(P1.4): interrupt 2 input</li> <li>- T2EX (P1.5): timer 2 external reload trigger input</li> <li>- CLKOUT (P1.6): system clock output</li> <li>- T2 (P1.7): counter 2 input</li> </ul>
$V_{\text{BB}}$	37		Substrate pin. Must be connected to $V_{\text{SS}}$ through a capacitor (47 to 100 nF) for proper operation of the A/D converter.
XTAL2	39	-	XTAL2 is the output from the oscillator's amplifier. Input to the internal timing circuitry. A crystal, ceramic resonator, or external source can be used.
XTAL1	40	-	XTAL1 is the input to the oscillator's high gain amplifier. Required when a crystal or ceramic resonator is used. Connect to $V_{\text{SS}}$ when external source is used on XTAL2.

**Pin Definitions and Functions (cont'd)**

Symbol	Pin	Input (I) Output (O)	Function
P2.0-P2.7	41- 48	I/O	Port 2 is an 8-bit quasi-bidirectional I/O port. It also emits the high-order address byte when accessing external memory. It is used for the high-order address and the control signals during program verification. Port 2 can sink/source 4 LS-TTL loads.
PSEN	49	O	The program store enable output is a control signal that enables the external program memory to the bus during external fetch operations. It is activated every six oscillator periods except during external data memory accesses. Remains high during internal program execution.
ALE	50	O	Provides address latch enable output used for latching the address into external memory during normal operation. It is activated every six oscillator periods except during an external data memory access.
$\overline{EA}$	51	I	When held at a TTL high level, the SAB 80515 executes instructions from the internal ROM when the PC is less than 8192. When held at a TTL low level, the SAB 80515 fetches all instructions from external program memory. For the SAB 80535 this pin must be tied low.
P0.0-P0.7	52-59	I/O	Port 0 is an 8-bit open-drain bidirectional I/O port. It is also the multiplexed low-order address and data bus when using external memory. It is used for data output during program verification. Port 0 can sink/source 8 LS-TTL loads.
P5.7-P5.0	60-67	I/O	Port 5 is an 8-bit quasi-bidirectional I/O port. Port 5 can sink/source 4 LS-TTL loads.
$V_{CC}$	68		POWER SUPPLY (+ 5 V power supply during normal operation and program verification)
$V_{SS}$	38		GROUND (0 V)

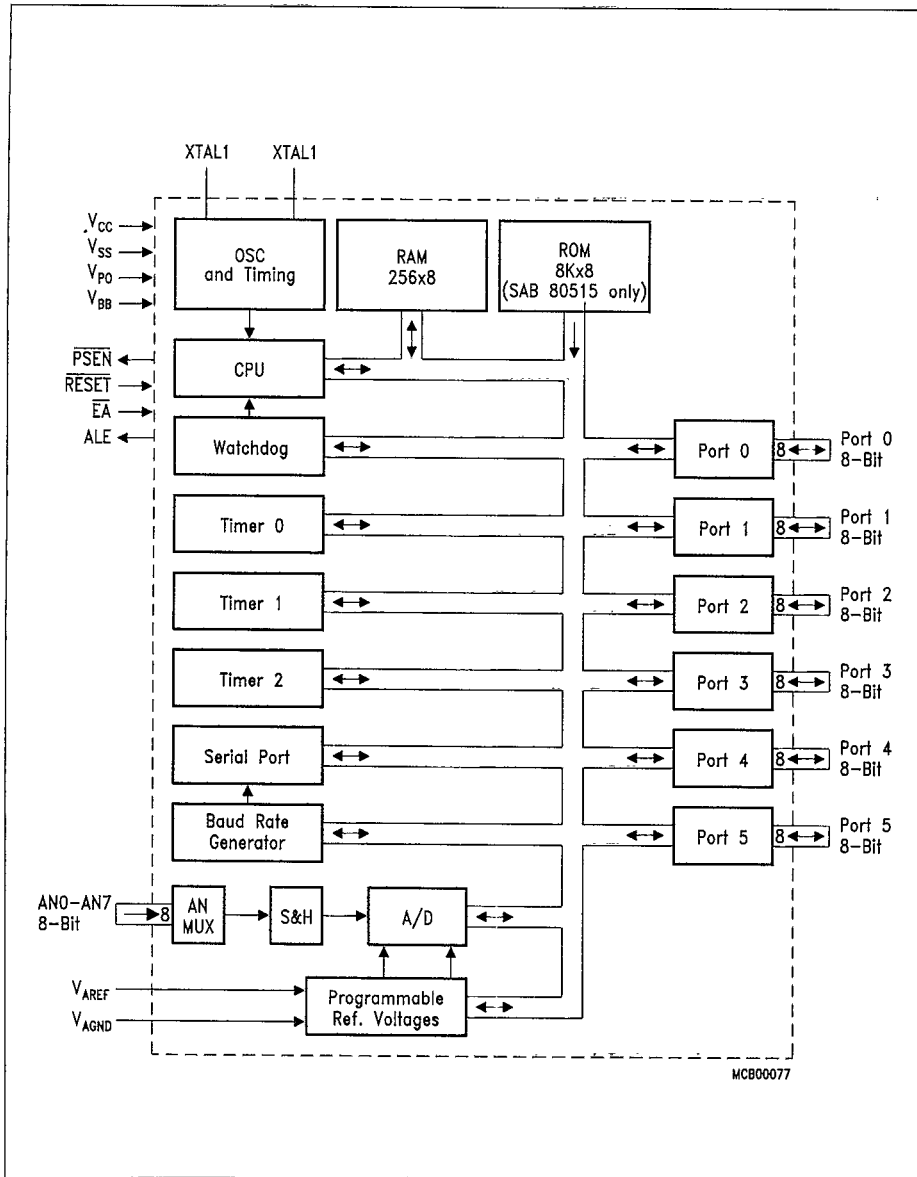

Figure 1  
Block Diagram



**Functional Description**

The architecture of the SAB 80515 is based on the SAB 8051 microcontroller family. The following features of the SAB 80515 are fully compatible with the SAB 8051 features:

- Instruction set
- External memory expansion interface (port 0 and port 2)
- Full-duplex serial port
- Timer/counter 0 and 1
- Alternate functions on port 3
- The lower 128 bytes of internal RAM and the lower 4 Kbytes of internal ROM

The SAB 80515 additionally contains 128 bytes of internal RAM and 4 Kbytes of internal ROM, which results in a total of 256 bytes of RAM and 8 Kbytes of ROM on chip. The SAB 80515 has a new 16-bit timer/counter with a 2:1 prescaler, reload mode, compare and capture capability. It also contains a 16-bit watchdog timer, an 8-bit A/D converter with programmable reference voltages, two additional quasi-bidirectional 8-bit ports, one 8-bit input port for analog signals, and a programmable clock output ( $f_{OSC}/12$ ).

Furthermore, the SAB 80515 has a powerful interrupt structure with 12 vectors and 4 programmable priority levels.

Figure 1 shows a block diagram of the SAB 80515.

**CPU**

The SAB 80515 is efficient both as a controller and as an arithmetic processor. It has extensive facilities for binary and BCD arithmetic and excels in its bit-handling capabilities. Efficient use of program memory results from an instruction set consisting of 44% one-byte, 41% two-byte, and 15% three-byte instructions. With a 12 MHz crystal, 58% of the instructions execute in 1.0  $\mu$ s.

**Memory Organization**

The SAB 80515 manipulates operands in the four memory address spaces described in the following. (Figure 2 illustrates the memory address spaces of the SAB 80515).

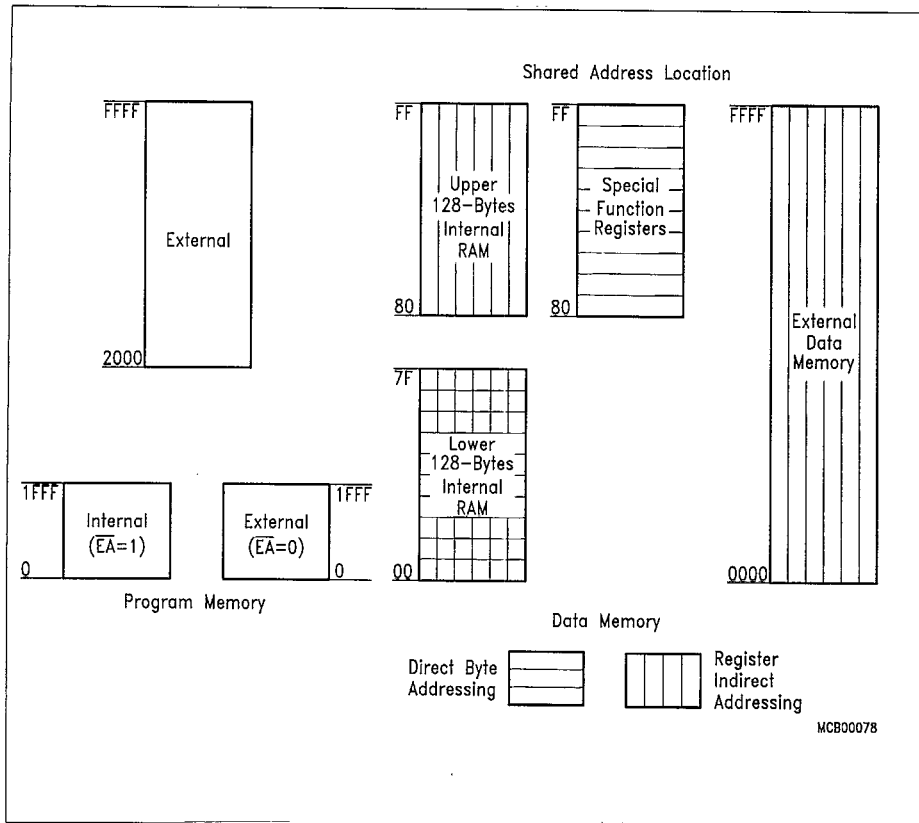

**Figure 2**  
Memory Address Spaces

**Program memory**

The SAB 80515 has 8 Kbyte of on-chip ROM, while the SAB 80535 has no internal ROM. The program memory can be externally expanded up to 64 Kbytes. If the  $\overline{EA}$  pin is held high, the SAB 80515 executes out of internal ROM unless the address exceeds 1FFFFH. Locations 2000H through 0FFFFH are then fetched from the external program memory. If the  $\overline{EA}$  pin is held low, the SAB 80515 fetches all instructions from the external program memory. Since the SAB 80535 has no internal ROM, pin  $\overline{EA}$  must be tied low when using this component.

**Data Memory**

The data memory address space consists of an internal and an external memory space. The internal data memory is divided into three physically separate and distinct blocks: the lower 128 bytes of RAM, the upper 128 bytes of RAM, and the 128-byte special function register (SFR) area. While the upper 128 bytes of data memory and the SFR area share the same address locations, they are accessed through different addressing modes. The lower 128 bytes of data memory can be accessed through direct or register indirect addressing; the upper 128 bytes of RAM can be accessed through register indirect addressing; the special function registers are accessible through direct addressing.

Four 8-register banks, each bank consisting of eight 8-bit multi-purpose registers, occupy locations 0 through 1FH in the lower RAM area. The next 16 bytes, locations 20H through 2FH, contain 128 directly addressable bit locations. The stack can be located anywhere in the internal data memory address space, and the stack depth can be expanded up to 256 bytes.

The external data memory can be expanded up to 64 Kbytes and can be accessed by instructions that use a 16-bit or an 8-bit address.

**Special Function Registers**

All registers, except the program counter and the four 8-register banks, reside in the special function register area. The 41 special function registers (SFR's) include arithmetic registers, pointers, and registers that provide an interface between the CPU and the on-chip peripheral functions. There are also 128 directly addressable bits within the SFR area. The special function registers are listed in the following table:

In table 1 they are organized in numeric order of their addresses. In table 2 they are organized in groups which refer to the functional blocks of the SAB 80515/80535.

**Table 1  
Special Function Register**

Address	Register	Contents after Reset	Address	Register	Contents after Reset
80H	P0 <sup>1)</sup>	0FFH	98H	SCON <sup>1)</sup>	00H
81H	SP	07H	99H	SBUF	XXXX XXXX B
82H	DPL	00H	9AH	reserved	XXH <sup>2)</sup>
83H	DPH	00H	9BH	reserved	XXH <sup>2)</sup>
84H	reserved	XXH <sup>2)</sup>	9CH	reserved	XXH <sup>2)</sup>
85H	reserved	XXH <sup>2)</sup>	9DH	reserved	XXH <sup>2)</sup>
86H	reserved	XXH <sup>2)</sup>	9EH	reserved	XXH <sup>2)</sup>
87H	PCON	000X 0000B <sup>2)</sup>	9FH	reserved	XXH <sup>2)</sup>
88H	TCON <sup>1)</sup>	00H	A0H	P2 <sup>1)</sup>	0FFH
89H	TMOD	00H	A1H	reserved	XXH <sup>2)</sup>
8AH	TL0	00H	A2H	reserved	XXH <sup>2)</sup>
8BH	TL1	00H	A3H	reserved	XXH <sup>2)</sup>
8CH	TH0	00H	A4H	reserved	XXH <sup>2)</sup>
8DH	TH1	00H	A5H	reserved	XXH <sup>2)</sup>
8EH	reserved	XXH <sup>2)</sup>	A6H	reserved	XXH <sup>2)</sup>
8FH	reserved	XXH <sup>2)</sup>	A7H	reserved	XXH <sup>2)</sup>
90H	P1 <sup>1)</sup>	0FFH	A8H	IENO <sup>1)</sup>	00H
91H	reserved	XXH <sup>2)</sup>	A9H	IPO	X000 0000B <sup>2)</sup>
92H	reserved	XXH <sup>2)</sup>	AAH	reserved	XXH <sup>2)</sup>
93H	reserved	XXH <sup>2)</sup>	ABH	reserved	XXH <sup>2)</sup>
94H	reserved	XXH <sup>2)</sup>	ACH	reserved	XXH <sup>2)</sup>
95H	reserved	XXH <sup>2)</sup>	ADH	reserved	XXH <sup>2)</sup>
96H	reserved	XXH <sup>2)</sup>	AEH	reserved	XXH <sup>2)</sup>
97H	reserved	XXH <sup>2)</sup>	AFH	reserved	XXH <sup>2)</sup>

<sup>1)</sup> Bit-addressable Special Function Register

<sup>2)</sup> X means that the value is indeterminate and the location is reserved

**Table 1**  
**Special Function Register (cont'd)**

Address	Register	Contents after Reset	Address	Register	Contents after Reset
<b>B0H</b>	<b>P3<sup>1)</sup></b>	<b>0FFH</b>	<b>D0H</b>	<b>PSW<sup>1)</sup></b>	<b>00H</b>
B1H	reserved	XXH <sup>2)</sup>	D1H	reserved	XXH <sup>2)</sup>
B2H	reserved	XXH <sup>2)</sup>	D2H	reserved	XXH <sup>2)</sup>
B3H	reserved	XXH <sup>2)</sup>	D3H	reserved	XXH <sup>2)</sup>
B4H	reserved	XXH <sup>2)</sup>	D4H	reserved	XXH <sup>2)</sup>
B5H	reserved	XXH <sup>2)</sup>	D5H	reserved	XXH <sup>2)</sup>
B6H	reserved	XXH <sup>2)</sup>	D6H	reserved	XXH <sup>2)</sup>
B7H	reserved	XXH <sup>2)</sup>	D7H	reserved	XXH <sup>2)</sup>
<b>B8H</b>	<b>IEN1<sup>1)</sup></b>	<b>00H</b>	<b>D8H</b>	<b>ADCON</b>	<b>00X0 0000 B<sup>2)</sup></b>
B9H	IP1	XX00 0000B <sup>2)</sup>	D9H	ADDAT	00H
BAH	reserved	XXH <sup>2)</sup>	DAH	DAPR	00H
BBH	reserved	XXH <sup>2)</sup>	DBH	P6	
BCH	reserved	XXH <sup>2)</sup>	DCH	reserved	XXH <sup>2)</sup>
BDH	reserved	XXH <sup>2)</sup>	DDH	reserved	XXH <sup>2)</sup>
BEH	reserved	XXH <sup>2)</sup>	DEH	reserved	XXH <sup>2)</sup>
BFH	reserved	XXH <sup>2)</sup>	DFH	reserved	XXH <sup>2)</sup>
<b>C0H</b>	<b>IRCON<sup>1)</sup></b>	<b>00H</b>	<b>E0H</b>	<b>ACC<sup>1)</sup></b>	<b>00H</b>
C1H	CCEN	00H	E1H	reserved	XXH <sup>2)</sup>
C2H	CCL1	00H	E2H	reserved	XXH <sup>2)</sup>
C3H	CCH1	00H	E3H	reserved	XXH <sup>2)</sup>
C4H	CCL2	00H	E4H	reserved	XXH <sup>2)</sup>
C5H	CCH2	00H	E5H	reserved	XXH <sup>2)</sup>
C6H	CCL3	00H	E6H	reserved	XXH <sup>2)</sup>
C7H	CCH3	00H	E7H	reserved	XXH <sup>2)</sup>
<b>C8H</b>	<b>T2CON<sup>1)</sup></b>	<b>00H</b>	<b>E8H</b>	<b>P4<sup>1)</sup></b>	<b>0FFH</b>
C9H	reserved	XXH <sup>2)</sup>	E9H	reserved	XXH <sup>2)</sup>
CAH	CRCL	00H	EAH	reserved	XXH <sup>2)</sup>
CBH	CRCH	00H	EBH	reserved	XXH <sup>2)</sup>
CCH	TL2	00H	ECH	reserved	XXH <sup>2)</sup>
CDH	TH2	00H	EDH	reserved	XXH <sup>2)</sup>
CEH	reserved	XXH <sup>2)</sup>	EEH	reserved	XXH <sup>2)</sup>
CFH	reserved	XXH <sup>2)</sup>	EFH	reserved	XXH <sup>2)</sup>

<sup>1)</sup> Bit-addressable Special Function Register

<sup>2)</sup> X means that the value is indeterminate and the location is reserved

**Table 1**  
**Special Function Register (cont'd)**

Address	Register	Contents after Reset	Address	Register	Contents after Reset
<b>F0H</b>	<b>B<sup>1)</sup></b>	<b>00H</b>	<b>F8H</b>	<b>P5<sup>1)</sup></b>	<b>0FFH</b>
F1H	reserved	XXH <sup>2)</sup>	F9H	reserved	XXH <sup>2)</sup>
F2H	reserved	XXH <sup>2)</sup>	FAH	reserved	XXH <sup>2)</sup>
F3H	reserved	XXH <sup>2)</sup>	FBH	reserved	XXH <sup>2)</sup>
F4H	reserved	XXH <sup>2)</sup>	FCH	reserved	XXH <sup>2)</sup>
F5H	reserved	XXH <sup>2)</sup>	FDH	reserved	XXH <sup>2)</sup>
F6H	reserved	XXH <sup>2)</sup>	FEH	reserved	XXH <sup>2)</sup>
F7H	reserved	XXH <sup>2)</sup>	FFH	reserved	XXH <sup>2)</sup>

<sup>1)</sup> Bit-addressable Special Function Register

<sup>2)</sup> X means that the value is indeterminate and the location is reserved

**Table 2**  
**Special Function Registers - Functional Blocks**

Block	Symbol	Name	Address	Contents after Reset	
CPU	ACC	Accumulator	<b>0E0H</b> <sup>1)</sup>	00H	
	B	B-Register	<b>0F0H</b> <sup>1)</sup>	00H	
	DPH	Data Pointer, High Byte	083H	00H	
	DPL	Data Pointer, Low Byte	082H	00H	
	PSW	Program Status Word Register	<b>0D0H</b> <sup>1)</sup>	00H	
	SP	Stack Pointer	081H	07H	
A/D-Converter	ADCON <sup>2)</sup>	A/D Converter Control Register	<b>0D8H</b> <sup>1)</sup>	00X0 0000 B <sup>3)</sup>	
	ADDAT	A/D Converter Data Register	09DH	00H	
	DAPR	A/D Converter Program Register	0DAH	00H)	
Interrupt System	IEN0 <sup>2)</sup>	Interrupt Enable Register 0	<b>0A8H</b> <sup>1)</sup>	00H	
	IEN1 <sup>2)</sup>	Interrupt Enable Register 1	<b>0B8H</b> <sup>1)</sup>	00H	
	IP0 <sup>2)</sup>	Interrupt Priority Register 0	0A9H	X000 0000 B <sup>3)</sup>	
	IP1	Interrupt Priority Register 1	0B9H	XX00 0000 B <sup>3)</sup>	
	IRCON	Interrupt Request Control Register	<b>0C0H</b> <sup>1)</sup>	00H	
	TCON <sup>2)</sup>	Timer Control Register	<b>88H</b> <sup>1)</sup>	00H	
T2CON <sup>2)</sup>	Timer 2 Control Register	<b>0C8H</b> <sup>1)</sup>	00H		
Compare/ Capture- Unit	CCEN	Comp./Capture Enable Reg.	0C1H	00H	
	CCH1	Comp./Capture Reg. 1, High Byte	0C3H	00H	
	CCH2	Comp./Capture Reg. 2, High Byte	0C5H	00H	
	CCH3	Comp./Capture Reg. 3, High Byte	0C7H	00H	
	Compare/ Capture- Unit (CCU)	CCL1	Comp./Capture Reg. 1, Low Byte	0C2H	00H
		CCL2	Comp./Capture Reg. 2, Low Byte	0C4H	00H
		CCL3	Comp./Capture Reg. 3, Low Byte	0C6H	00H
	(cont'd) (CCU)	CRCH	Com./Rel./Capt. Reg. High Byte	0CBH	00H
		CRCL	Com./Rel./Capt. Reg. Low Byte	0CAH	00H
		TH2	Timer 2, High Byte	0CDH	00H
		TL2	Timer 2, Low Byte	0CCH	00H
		T2CON <sup>2)</sup>	Timer 2 Control Register <sup>1)</sup>	<b>0C8H</b> <sup>1)</sup>	00H

1) Bit-addressable special function registers

2) This special function register is listed repeatedly since some bits of it also belong to other functional blocks

3) X means that the value is indeterminate

**Table 2**  
**Special Function Registers- Functional Blocks (cont'd)**

Block	Symbol	Name	Address	Contents after Reset
Ports	P0	Port 0	<b>80H</b> <sup>1)</sup>	0FFH
	P1	Port 1	<b>90H</b> <sup>1)</sup>	0FFH
	P2	Port 2	<b>0A0H</b> <sup>1)</sup>	0FFH
	P3	Port 3	<b>0B0H</b> <sup>1)</sup>	0FFH
	P4	Port 4	<b>0E8H</b> <sup>1)</sup>	0FFH
	P5	Port 5	<b>0F8H</b> <sup>1)</sup>	0FFH
	P6	Port 6, Analog/Digital Input	0DBH	
Pow. Sav. Modes	PCON <sup>2)</sup>	Power Control Register	087H	000X 0000 B <sup>2)</sup>
Serial Channels	ADCON <sup>2)</sup>	A/D Converter Control Reg.	<b>0D8H</b> <sup>1)</sup>	00X0 0000 B <sup>3)</sup>
	PCON <sup>2)</sup>	Power Control Register	087H	000X 0000 B <sup>3)</sup>
	SBUF	Serial Channel Buffer Reg.	099H	XXXX XXXX B <sup>3)</sup>
	SCON	Serial Channel Control Reg.	<b>098H</b> <sup>1)</sup>	00H
Timer 0/ Timer 1	TCON <sup>2)</sup>	Timer Control Register	<b>088H</b> <sup>1)</sup>	00H
	TH0	Timer 0, High Byte	08CH	00H
	TH1	Timer 1, High Byte	08DH	00H
	TL0	Timer 0, Low Byte	08AH	00H
	TL1	Timer 1, Low Byte	08BH	00H
	TMOD	Timer Mode Register	089H	00H
Watchdog	IEN0 <sup>2)</sup>	Interrupt Enable Register 0	<b>0A8H</b> <sup>1)</sup>	00H
	IEN1 <sup>2)</sup>	Interrupt Enable Register 1	<b>0B8H</b> <sup>1)</sup>	00H
	IPO <sup>2)</sup>	Interrupt Priority Register 0	0A9H	X000 0000 B <sup>3)</sup>

1) Bit-addressable special function registers

2) This special function register is listed repeatedly since some bits of it also belong to other functional blocks.

3) X means that the value is indeterminate and the location is reserved



### Serial Port

The serial port of the SAB 80515 enables full duplex communication between microcontrollers or between microcontroller and peripheral devices. The serial port can operate in 4 modes:

- Mode 0: Shift register mode. Serial data enters and exits through RxD. TxD outputs the shift clock. 8 bits are transmitted/received: 8 data bits (LSB first). The baud rate is fixed at 1/12 of the oscillator frequency.
- Mode 1: 10 bits are transmitted (through RxD) or received (through TxD): a start bit (0), 8 data bits (LSB first), and a stop bit (1). The baud rate is variable.
- Mode 2: 11 bits are transmitted (through RxD) or received (through TxD): a start bit (0), 8 data bits (LSB first), a programmable 9th data bit, and a stop bit (1). The baud rate is programmable to either 1/32 or 1/64 of the oscillator frequency.
- Mode 3: 11 bits are transmitted (through TxD) or received (through RxD): a start bit (0), 8 data bits (LSB first), a programmable 9th data bit, and a stop bit (1). Mode 3 is identical to mode 2 except for the baud rate. The baud rate in mode 3 is variable.

The variable baud rates in modes 1 and 3 can be generated by timer 1 or an internal baud rate generator.

### A/D Converter

The 8-bit A/D converter of the SAB 80515 has eight multiplexed analog inputs (Port 6) and uses the successive approximation method.

It takes 5 machine cycles to sample an analog signal (during this sample time the input signal should be held constant); the total conversion time (including sample time) is 15 machine cycles (15  $\mu$ s at 12 MHz oscillator frequency). Conversion can be programmed to be single or continuous; at the end of a conversion an interrupt can be generated.

A unique feature is the capability of internal reference voltage programming. The internal reference voltages  $V_{IntAREF}$  and  $V_{IntAGND}$  for the A/D converter both are programmable to one of 16 steps with respect to the external reference voltages. This feature permits a conversion with a smaller internal reference voltage range to gain a higher resolution. In addition, the internal reference voltages can easily be adapted by software to the desired analog input voltage range.

Figure 3 shows a block diagram of the A/D converter.

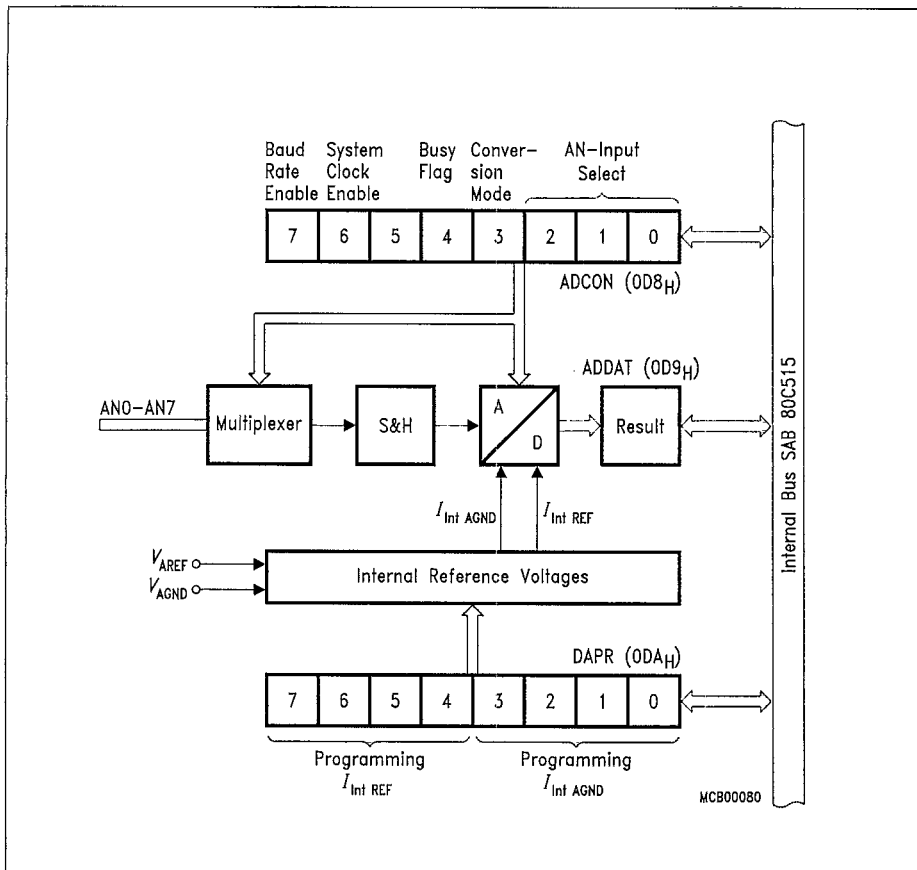

Figure 3  
Block Diagram of the A/D Converter

### Timer/Counters

The SAB 80515 contains three 16-bit timer/counters which are useful in many applications for timing and counting. The input clock for each timer/counter is 1/12 of the oscillator frequency in the timer operation or can be taken from an external clock source for the counter operation (maximum count rate is 1/24 of the oscillator frequency).

#### – Timer/counter 0 and 1

These timer/counters can operate in four modes:

Mode 0: 8-bit timer/counter with 32:1 prescaler

Mode 1: 16-bit timer/counter

Mode 2: 8-bit timer/counter with 8-bit auto-reload

Mode 3: Timer/counter 0 is configured as one 8-bit timer/counter and one 8-bit timer; timer/counter 1 in this mode holds its count.

External inputs  $\overline{INT0}$  and  $\overline{INT1}$  can be programmed to function as a gate for timer/counters 0 and 1 to facilitate pulse width measurements.

#### – Timer/counter 2

Timer/counter 2 of the SAB 80515 is a 16-bit timer/counter with several additional features. It offers a 2:1 prescaler, a selectable gate function, and compare, capture and reload functions. Corresponding to the 16-bit timer register there are four 16-bit capture/compare registers, one of them can be used to perform a 16-bit reload on a timer overflow or external event. Each of these registers corresponds to a pin of port 1 for capture input/compare output. Figure 4 shows a block diagram of the timer/counter 2.

### Reload

A 16-bit reload can be performed with the 16-bit CRC register, which is a concatenation of the 8-bit registers CRCL and CRCH. There are two modes from which to select:

Mode 0: Reload is caused by a timer 2 overflow (auto-reload).

Mode 1: Reload is caused in response to a negative transition at pin T2EX (P1.5), which can also request an interrupt.

### Capture

This feature permits saving the actual timer/counter contents into a selected register upon an external event or a software write operation. Two modes are provided to latch the current 16-bit value in timer 2 registers into a dedicated capture register:

Mode 0: Capture is performed in response to a transition at the corresponding port 1 pins CC0 to CC3.

Mode 1: Write operation into the low-order byte of the dedicated capture register causes the timer 2 contents to be latched into this register.

**Compare**

In the compare mode, the 16-bit values stored in the dedicated compare registers are compared to the contents of the timer 2 registers. If the count value in the timer 2 registers matches one of the stored values, an appropriate output signal is generated and an interrupt is requested. Two compare modes are provided:

Mode 0: Upon a match the output signal changes from low to high. It goes back to a low level when timer 2 overflows.

Mode 1: The transition of the output signal can be determined by software.  
A timer 2 overflow causes no output change.

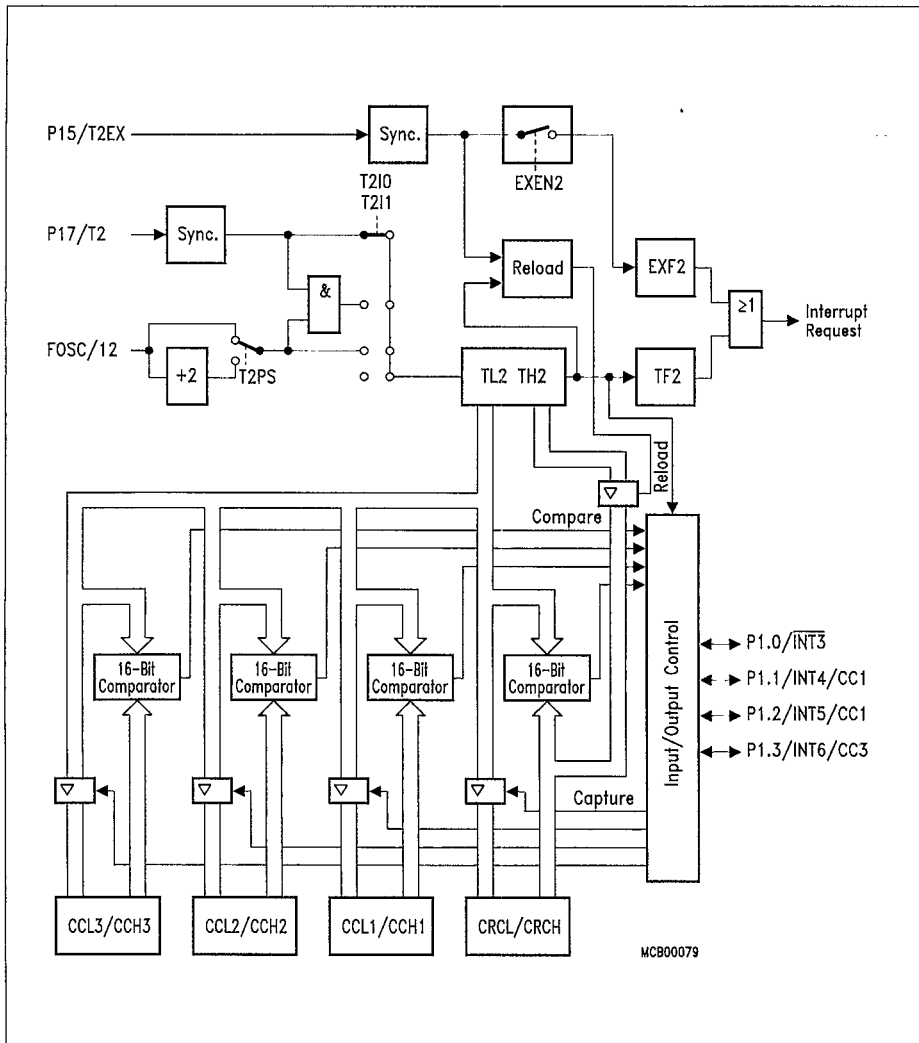

**Figure 4**  
Block Diagram of Timer/Counter 2

**Interrupt Structure**

The SAB 80515 has 12 interrupt vectors with the following vector addresses and request flags:

**Table 3  
Interrupt Sources and Vectors**

Source (Request Flags)	Vector Address	Vector
IE0	0003H	External interrupt 0
TF0	000BH	Timer 0 interrupt
IE1	0013H	External interrupt 1
TF1	001BH	Timer 1 interrupt
RI + TI	0023H	Serial port interrupt
TF2 + EXF2	002BH	Timer 2 interrupt
IADC	0043H	A/D converter interrupt
IEX2	004BH	External interrupt 2
IEX3	0053H	External interrupt 3
IEX4	005BH	External interrupt 4
IEX5	0063H	External interrupt 5
IEX6	006BH	External interrupt 6

Each interrupt vector can be individually enabled/disabled. The minimum response time to an interrupt request is more than 3 machine cycles and less than 9 machine cycles.

Figure 5 shows the interrupt request sources.

External interrupts 0 and 1 can be activated by a low-level or a negative transition (selectable) at their corresponding input pin, external interrupts 2 and 3 can be programmed for triggering on a negative or a positive transition. The external interrupts 3 to 6 are combined with the corresponding alternate functions compare (output) and capture (input) on port 1.

For programming of the priority levels the interrupt vectors are combined to pairs. Each pair can be programmed individually to one of four priority levels by setting or clearing one bit in the special function register IP0 and one in IP1. Figure 6 shows the priority level structure.

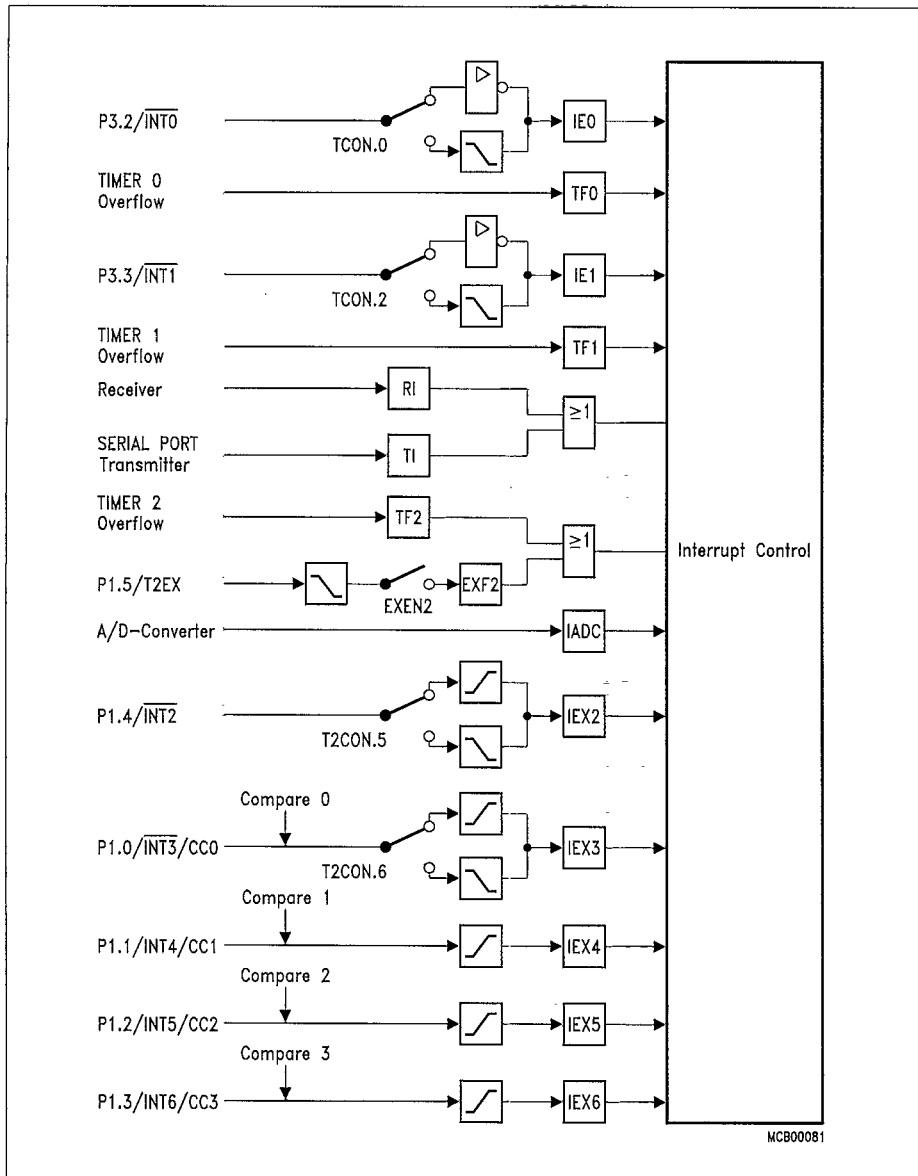

**Figure 5**  
**Interrupt Request Sources**

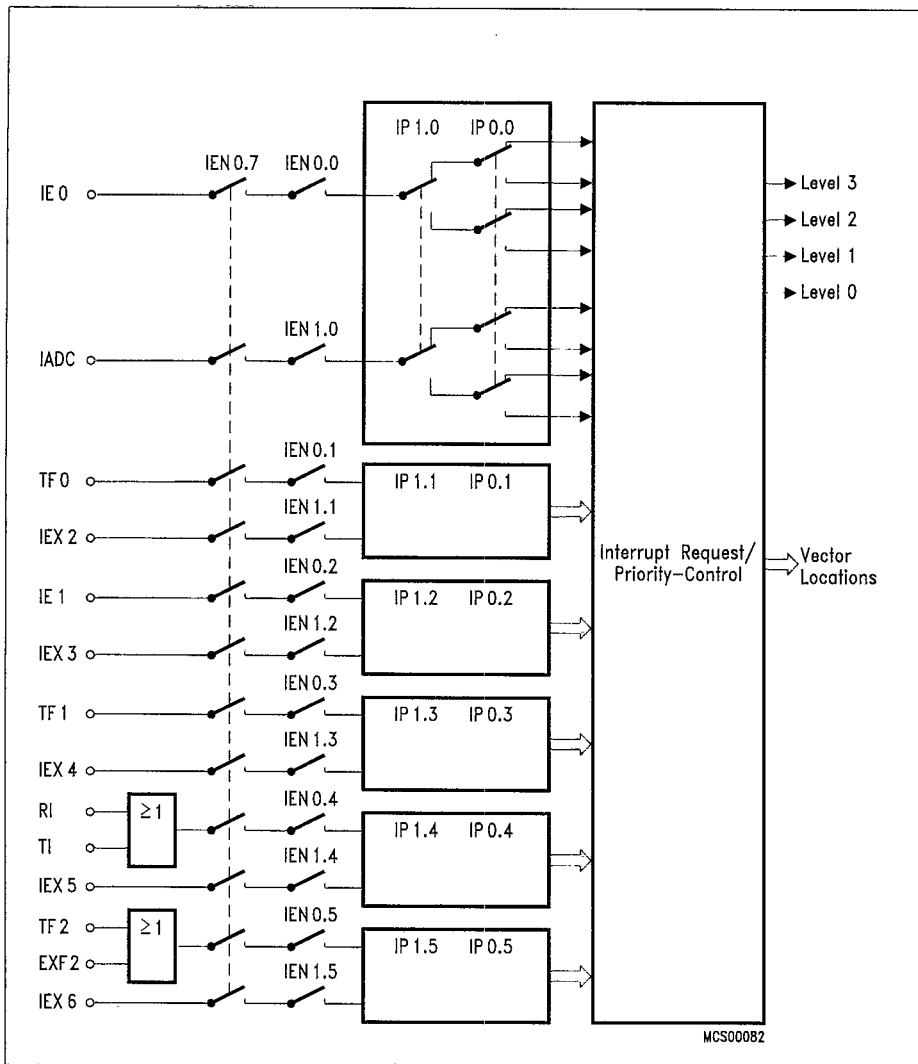

**Figure 6**  
**Priority Level Structure**



**I/O Ports**

The SAB 80515 has six 8-bit I/O ports and one 8-bit input port. Port 0 is an open-drain bidirectional I/O port, while ports 1 to 5 are quasi-bidirectional I/O ports with internal pull-up resistors. That means, when configured as inputs, ports 1 to 5 will be pulled high and will source current when externally pulled low. Port 0 will float when configured as input.

Port 0 and port 2 can be used to expand the program and data memory externally. During an access to external memory, port 0 emits the low-order address byte and reads/writes the data byte, while port 2 emits the high-order address byte. In this function, port 0 is not an open-drain port, but uses a strong internal pullup FET.

Ports 1 and 3 are provided for several alternate functions, as listed below:

Port	Symbol	Function
P1.0	$\overline{\text{INT3/CC0}}$	External interrupt 3 input, compare 0 output, capture 0 input
P1.1	$\overline{\text{INT4/CC1}}$	External interrupt 4 input, compare 1 output, capture 1 input
P1.2	$\overline{\text{INT5/CC2}}$	External interrupt 5 input, compare 2 output, capture 2 input
P1.3	$\overline{\text{INT6/CC3}}$	External interrupt 6 input, compare 3 output, capture 3 input
P1.4	$\overline{\text{INT2}}$	External interrupt 2 input
P1.5	T2EX	Timer 2 external reload trigger input
P1.6	CLKOUT	System clock output
P1.7	T2	Timer 2 external counter input
P3.0	RXD	Serial port's receiver data input (asynchronous) or data input/output (synchronous)
P3.1	TXD	Serial port's transmitter data output (asynchronous) or clock output (synchronous)
P3.2	$\overline{\text{INT0}}$	External interrupt 0 input, timer 0 gate control
P3.3	$\overline{\text{INT1}}$	External interrupt 1 input, timer 1 gate control
P3.4	T0	Timer 0 external counter input
P3.5	T1	Timer 1 external counter input
P3.6	$\overline{\text{WR}}$	External data memory write strobe
P3.7	$\overline{\text{RD}}$	External data memory read strobe

The input port AN0-AN7 is used for analog input signals to the A/D converter.

**Watchdog Timer**

This feature is provided as a means of graceful recovery from a software upset. After an external reset, the watchdog timer is cleared and stopped. It can be started and cleared by software, but it cannot be stopped. If the software fails to clear the watchdog timer at least every 65532 machine cycles (about 65 ms if a 12 MHz oscillator frequency is used), an internal hardware reset will be initiated.

The reset cause (external reset or reset caused by the watchdog) can be examined by software. To clear the watchdog, two bits in two different special function registers must be set by two consecutive instructions (bits IEN0.6 and IEN1.6). This is done to prevent the watchdog from being cleared by unexpected opcodes.

**Instruction Set Summary**

The SAB 80515/80535 has the same instruction set as the industry standard 8051 microcontroller.

A pocket guide is available which contains the complete instruction set in functional and hexadecimal order. Furtheron it provides helpful information about Special Function Registers, Interrupt Vectors and Assembler Directives.

**Literature Information**

<b>Title</b>	<b>Ordering No.</b>
Microcontroller Family SAB 8051 Pocket Guide	B158-B6599 - X - X - 7600

**Absolute Maximum Ratings**

Ambient temperature under bias

SAB 80515/80535 ..... 0 to 70 °C

SAB 80515/80535-T40/85 ..... - 40 to 85 °C

SAB 80515/80535-T40/110 ..... - 40 to 110 °C

Storage temperature ..... - 65 to 150 °C

Voltage on any pins with respect to ground ( $V_{SS}$ ) ..... - 0.5 V to 7 V

Power dissipation ..... 2 W

**Note** Stresses above those listed under "Absolute Maximum Ratings" may cause permanent damage of the device. Exposure to absolute maximum rating conditions for extended periods may affect device reliability.

**DC Characteristics**

$V_{CC} = 5 V \pm 10 \%$ ;  $V_{SS} = 0 V$

$T_A = 0$  to 70 °C for the SAB 80515/80535  
 $T_A = -40$  to 85 °C for the SAB 80515/80535-T40/85  
 $T_A = -40$  to 110 °C for the SAB 80515/80535-T40/110

Parameter	Symbol	Limit values		Unit	Test condition
		min.	max.		
Input low voltage	$V_{IL}$	- 0.5	0.8	V	-
Input high voltage) (except RESET, XTAL2	$V_{IH}$	2.0	$V_{CC} - 0.5$	V	-
Input high voltage to XTAL2	$V_{IH1}$	2.5	$V_{CC} + 0.5$	V	XTAL1 to $V_{SS}$
Input high voltage to $\overline{RESET}$	$V_{IH2}$	3.0	-	V	-
Power down voltage	$V_{PD}$	3	5.5	V	$V_{CC} = 0 V$
Output low voltage ports 1, 2, 3, 4, 5	$V_{OL}$	-	0.45	V	$I_{OL} = 1.6 mA^{1)}$
Output low voltage port 0, ALE, PSEN	$V_{OL1}$	-	0.45	V	$I_{OL} = 3.2 mA^{1)}$
Output high voltage ports 1, 2, 3, 4, 5	$V_{OH}$	2.4	-	V	$I_{OH} = - 80 \mu A$
Output high voltage port 0, ALE, PSEN	$V_{OH1}$	2.4	-	V	$I_{OH} = - 400 \mu A$

<sup>1)</sup> Capacitive loading on ports 0 and 2 may cause spurious noise pulses to be superimposed on the  $V_{OL}$  of ALE and ports 1,3,4,5. The noise is due to external bus capacitance discharging into the port 0 and port 2 pins when these pins make 1-0 transitions during bus operation.

**DC Characteristics (cont'd)**

Parameter	Symbol	Limit values		Unit	Test condition
		min.	max.		
Logic 0 input current ports 1, 2, 3, 4, 5	$I_{IL}$	–	– 800	$\mu\text{A}$	$V_{IL} = 0.45 \text{ V}$
Logic 0 input current XTAL2	$I_{IL2}$	–	– 2.5	mA	$XTAL1 = V_{SS}$ $V_{IL} = 0.45 \text{ V}$
Input low current to $\overline{\text{RESET}}$ for reset	$I_{IL3}$	–	– 500	$\mu\text{A}$	$V_{IL} = 0.45 \text{ V}$
Input leakage current to port 0, $\overline{\text{EA}}$ AN0 - AN7	$I_{LI}$	–	$\pm 10$	$\mu\text{A}$	$0 \text{ V} < V_{IN} < V_{CC}$
Power supply current: <sup>1)</sup> SAB 80515/80535 SAB 80515/80535-T40/85 SAB 80515/80535-T40/110	$I_{CC}$ $I_{CC}$ $I_{CC}$	– – –	210 230 230	mA mA mA	all outputs disconnected
Power-down current	$I_{PD}$	–	3	mA	$V_{CC} = 0 \text{ V}$
Capacitance of I/O buffer	$C_{IO}$	–	10	pF	$f_C = 1 \text{ MHz}$

<sup>1)</sup> Capacitive loading on ports 0 and 2 may cause spurious noise pulses to be superimposed on the  $V_{OL}$  of ALE and ports 1,3,4,5. The noise is due to external bus capacitance discharging into the port 0 and port 2 pins when these pins make 1-0 transitions during bus operation.

**A/D Converter Characteristics**

$V_{CC} = 5\text{ V} \pm 10\%$ ;  $V_{SS} = 0\text{ V}$ ;  $V_{AREF} = V_{CC} \pm 5\%$ ;  $V_{AGND} = V_{SS} \pm 0.2\text{ V}$ ;  
 $V_{IntAREF} - V_{IntAGND} \geq 1\text{ V}$ ;  $T_A = 0\text{ to }+70\text{ }^\circ\text{C}$  for SAB 80515/80535  
 $T_A = -40\text{ to }+85\text{ }^\circ\text{C}$  for SAB 80515/80535 - T40/85  
 $T_A = -40\text{ to }+110\text{ }^\circ\text{C}$  for SAB 80515/80535 - T40/110

Parameter	Symbol	Limit values			Unit	Test condition
		min.	typ.	max.		
Analog input voltage	$V_{AINPUT}$	$V_{AGND} - 0.2$	—	$V_{AREF} + 0.2$	V	—
Analog input capacitance	$C_I$	—	25	—	pF	1)
Load time	$t_L$	—	—	$2 t_{CY}$	$\mu\text{s}$	—
Sample time (incl. load time)	$t_S$	—	—	$5 t_{CY}$	$\mu\text{s}$	—
Conversion time (including sample time)	$t_C$	—	—	$15 t_{CY}$	$\mu\text{s}$	—
Differential non-linearity	DNLE	—	$\pm 1/2$	$\pm 1$	LSB	$V_{IntAREF} =$ $V_{AREF} = V_{CC}$ $V_{IntAGND} =$ $V_{AGND} = V_{SS}$ 2)
Integral non-linearity	INLE	—	$\pm 1/2$	$\pm 1$	LSB	
Offset error		—	$\pm 1/2$	$\pm 1$	LSB	
Gain error		—	$\pm 1/2$	$\pm 1$	LSB	
Total unadjusted error	TUE	—	$\pm 1$	$\pm 2$	LSB	
$V_{AREF}$ supply current	$I_{REF}$	—	—	5	mA	2)
Internal reference error	$V_{IntREFER}$	—	$\pm 5$	$\pm 15$	mV	2)

1) The internal resistance of the analog source must be low enough to assure full loading of the sample capacitance ( $C_I$ ) during load time ( $t_L$ ). After charging of the internal capacitance ( $C_I$ ) in the load time ( $t_L$ ) the analog input must be held constant for the rest of the sample time ( $t_S$ ).

2) The differential impedance  $r_D$  of the analog reference voltage source must be less than 1 k $\Omega$  at reference supply voltage.

**A/D Characteristics**

$V_{CC} = 5\text{ V} \pm 10\%$ ;  $V_{SS} = 0\text{ V}$ ; ( $C_L$  for port 0, ALE and PSEN outputs = 100 pF;  
 $C_L$  for all other outputs = 80 pF)  $T_A = 0$  to  $+70\text{ }^\circ\text{C}$ ; for SAB 80515/80535  
 $T_A = -40$  to  $+85\text{ }^\circ\text{C}$ ; for SAB 80515/80535 - 40/85  
 $T_A = -40$  to  $+110\text{ }^\circ\text{C}$ ; for SAB 80515/80535 - 40/110

Parameter	Symbol	Limit values				Unit
		12 MHz clock		Variable clock $1/t_{CLCL} = 1.2\text{ MHz to }12\text{ MHz}$		
		min	max.	min.	max.	

**Program Memory Characteristics**

Cycle Time	$t_{CY}$	1000	—	$12 t_{CLCL}$	—	ns
ALE pulse width	$t_{LHLL}$	127	—	$2 t_{CLCL} - 40$	—	ns
Address setup to ALE	$t_{AVLL}$	53	—	$t_{CLCL} - 30$	—	ns
Address hold after ALE	$t_{LLAX1}$	48	—	$t_{CLCL} - 35$	—	ns
ALE to valid instruction in	$t_{LLIV}$	—	233	—	$4 t_{CLCL} - 100$	ns
ALE to PSEN	$t_{LLPL}$	58	—	$t_{CLCL} - 25$	—	ns
PSEN pulse width	$t_{PLPH}$	215	—	$3 t_{CLCL} - 35$	—	ns
PSEN to valid instruction in	$t_{PLIV}$	—	150	—	$3 t_{CLCL} - 100$	ns
Input instruction hold after PSEN	$t_{PXIX}$	0	—	0	—	ns
Input instruction float after PSEN	$t_{PXIZ}^*)$	—	63	—	$t_{CLCL} - 20$	ns
Address valid after PSEN	$t_{PXAV}^*)$	75	—	$t_{CLCL} - 8$	—	ns
Address to valid instruction in	$t_{AVIV}$	—	302	—	$5 t_{CLCL} - 115$	ns
Address float to PSEN	$t_{AZPL}$	0	—	0	—	ns

<sup>\*)</sup> Interfacing the SAB 805156 to devices with float times up to 75 ns is permissible. This limited bus contention will not cause any damage to port 0 drivers.

Parameter	Symbol	Limit values				Unit
		12 MHz clock		Variable clock 1/t <sub>CLCL</sub> = 1.2 MHz to 12 MHz		
		min	max.	min.	max.	

**External Data Memory Characteristics**

$\overline{RD}$ pulse width	t <sub>RLRH</sub>	400	–	6 t <sub>CLCL</sub> – 100	–	ns
$\overline{WR}$ pulse width	t <sub>WLWH</sub>	400	–	6 t <sub>CLCL</sub> – 100	–	ns
Address hold after ALE	t <sub>LLAX2</sub>	132	–	2 t <sub>CLCL</sub> – 35	–	ns
$\overline{RD}$ to valid data in	t <sub>RLDV</sub>	–	252	–	5 t <sub>CLCL</sub> – 165	ns
DATA hold after $\overline{RD}$	t <sub>RHDX</sub>	0	–	0	–	ns
Data float after $\overline{RD}$	t <sub>RHDZ</sub>	–	97	–	2 t <sub>CLCL</sub> – 70	ns
ALE to valid data in	t <sub>LLDV</sub>	–	517	–	8 t <sub>CLCL</sub> – 150	ns
Address to valid data in	t <sub>AVDV</sub>	–	585	–	9 t <sub>nCLCL</sub> – 165	ns
ALE to $\overline{WR}$ or $\overline{RD}$	t <sub>LLWL</sub>	200	300	3 t <sub>CLCL</sub> – 50	3 t <sub>CLCL</sub> + 50	ns
Address to $\overline{WR}$ or $\overline{RD}$	t <sub>AVWL</sub>	203	–	4 t <sub>CLCL</sub> – 130	–	ns
$\overline{WR}$ or $\overline{RD}$ high to ALE high	t <sub>WHLH</sub>	43	123	t <sub>CLCL</sub> – 40	t <sub>CLCL</sub> + 40	ns
Data valid to $\overline{WR}$ transition	t <sub>QVWX</sub>	33	–	t <sub>CLCL</sub> – 50	–	ns
Data setup before $\overline{WR}$	t <sub>QVWH</sub>	433	–	7 t <sub>CLCL</sub> – 150	–	ns
Data hold after $\overline{WR}$	t <sub>WHQX</sub>	33	–	t <sub>CLCL</sub> – 50	–	ns
Address float after $\overline{RD}$	t <sub>RLAZ</sub>	–	0	–	0	ns





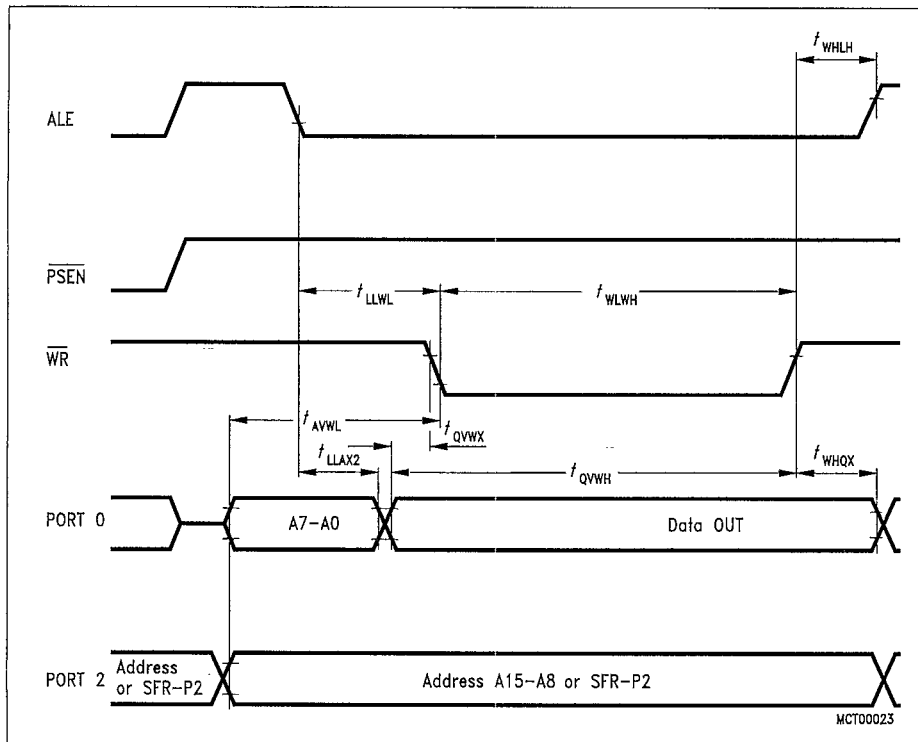

Data Memory Read Cycle

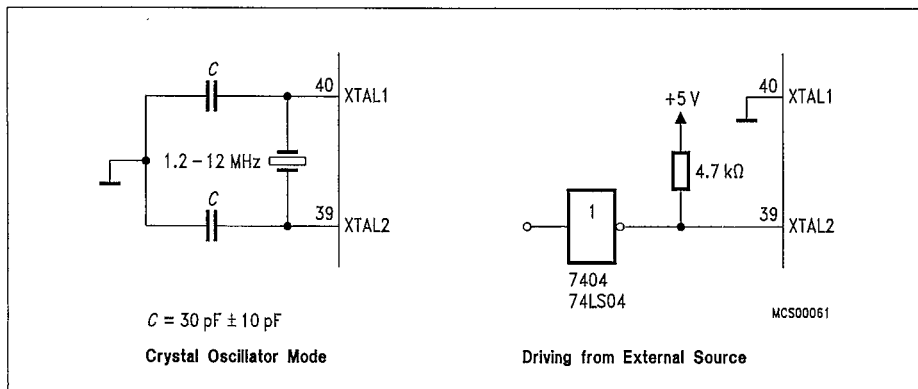

Recommended Oscillator Circuits

**AC Characteristics (cont'd)**

Parameter	Symbol	Limit values		Unit
		Variable clock Frequ. = 1.2 MHz to 12 MHz		
		min.	max.	

**External Clock Drive XTAL2**

Oscillator period	$t_{CLCL}$	83.3	833.3	ns
High time	$t_{CHCX}$	20	$t_{CLCL} - t_{CLCX}$	ns
Low time	$t_{CLCX}$	20	$t_{CLCL} - t_{CHCX}$	ns
Rise time	$t_{CLCH}$	-	20	ns
Fall time	$t_{CHCL}$	-	20	ns
Oscillator period	$t_{CLCL}$	83.3	833.3	ns

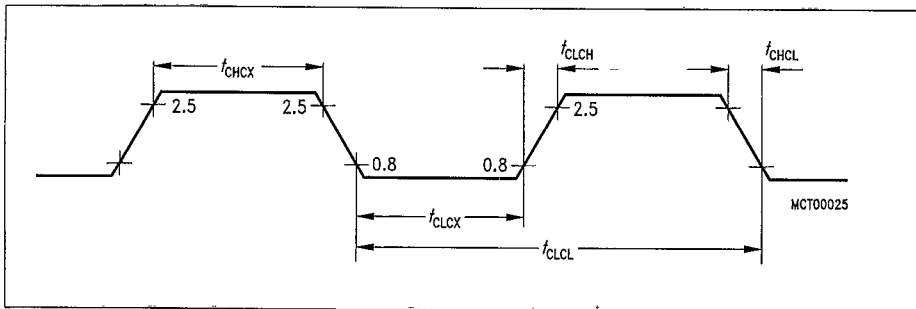

**External Clock Cycle**

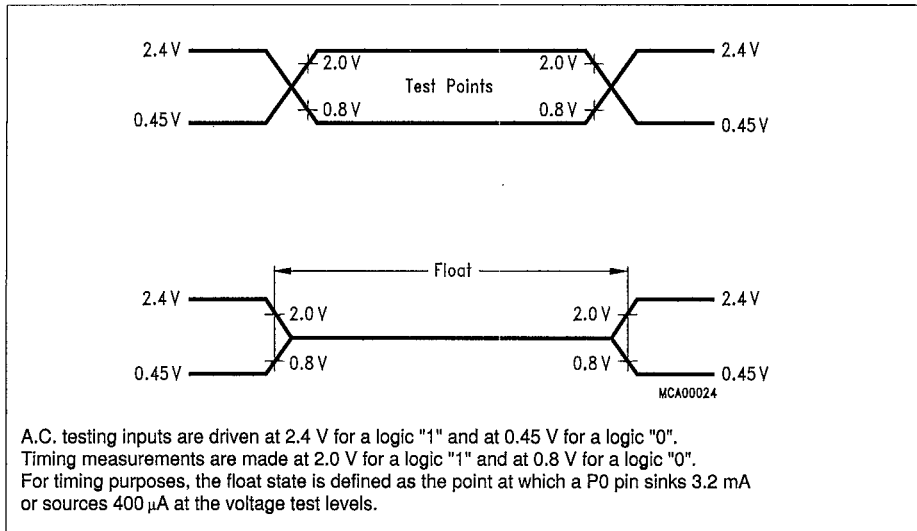

**A.C. Testing Input, Output, Float Waveforms**

**AC Characteristics (cont'd)**

Parameter	Symbol	Limit values				Unit
		16 MHz clock		Variable clock 1/t <sub>CLCL</sub> = 1.2 MHz to 12 MHz		
		min.	max.	min.	max.	

**System Clock Timing**

ALE to CLKOUT	t <sub>LLSH</sub>	543	—	7t <sub>CLCL</sub> - 40	—	ns
CLKOUT high time	t <sub>SHSL</sub>	127	—	2t <sub>CLCL</sub> - 40	—	ns
CLKOUT low time	t <sub>SLSH</sub>	793	—	10t <sub>CLCL</sub> - 40	—	ns
CLKOUT low to ALE high	t <sub>SLLH</sub>	43	123	t <sub>CLCL</sub> - 40	t <sub>CLCL</sub> + 40	ns

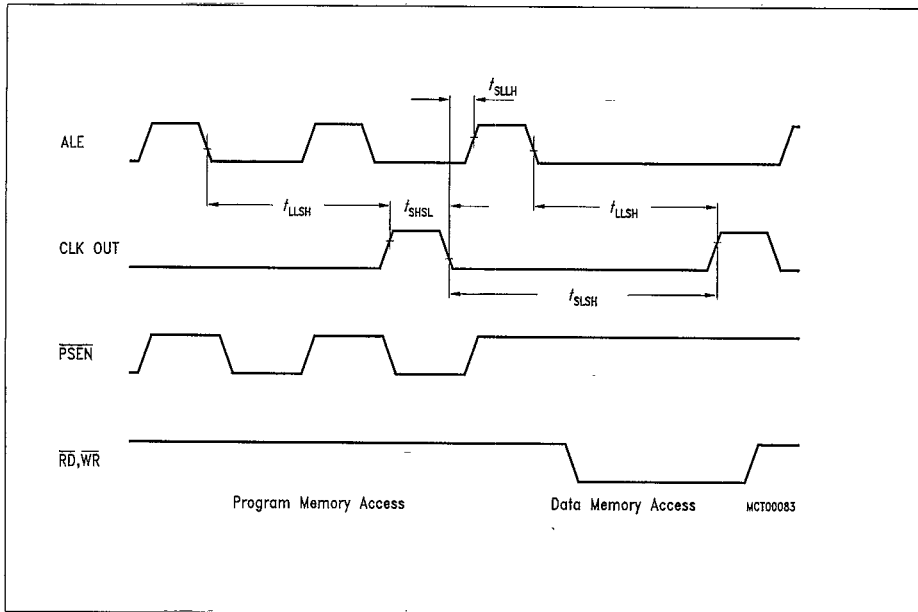

**System Clock Timing**

**ROM Verification Characteristics**

$T_A = 25^\circ\text{C} \pm 5^\circ\text{C}$ ;  $V_{CC} = 5\text{ V} \pm 10\%$ ;  $V_{SS} = 0\text{ V}$

Parameter	Symbol	Limit values		Unit
		min	max.	

**ROM Verification**

Address to valid data	$t_{AVQV}$	—	48 $t_{CLCL1}$	ns
ENABLE to valid data	$t_{ELQV}$	—	48 $t_{CLCL1}$	ns
Data float after ENABLE	$t_{EHOZ}$	0	48 $t_{CLCL1}$	ns
Oscillator frequency	$1/t_{CLCL}$	4	6	MHz

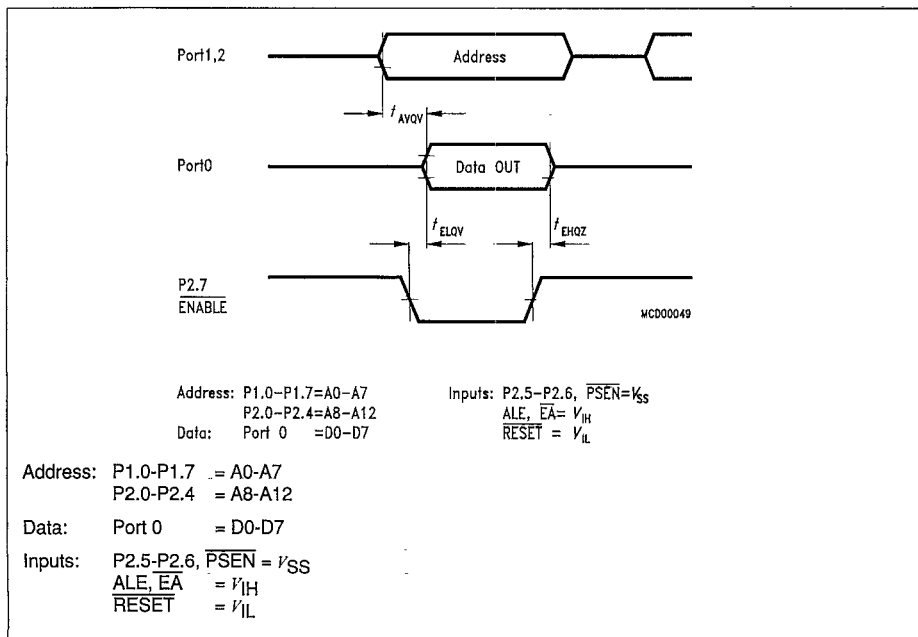

**ROM Verification**