

PC16552C Dual UART/DMA Micro Channel Adapter

National Semiconductor
Application Note 770
Greg DeJager
July 1991



PC16552C Dual UART/DMA Micro Channel Adapter

AN-770

Table Of Contents

INTRODUCTION AND FEATURES

PC16552C ADAPTER BLOCK DIAGRAM

PC16552C ADAPTER USER'S GUIDE

POS—PROGRAMMABLE OPTION SELECT

An overview of the Micro Channel Programmable Option Select (POS), a unique feature which replaces all adapter jumpers and switches with programmable configuration registers.

- A. POS Mechanism
- B. Adapter Description File (ADF)
- C. Configuration Utilities
- D. POS Registers
- E. PC16552C Adapter POS Register Design

MICRO CHANNEL BUS INTERFACE

General information on the adapter interface to the Micro Channel, applicable to any adapter design, and specific information on the design of the PC16552C Adapter.

- A. Micro Channel Control Signals
- B. Data Bus
- C. Address Decode
- D. UART Interface
- E. Interrupts

MICRO CHANNEL BUS ARBITRATION

An overview of the bus arbitration system implemented on all Micro Channel machines.

- A. Central Arbiter
- B. Local Arbiter

PC16552C ADAPTER DMA INTERFACE DESIGN

The design of the PC16552C Adapter's Local Arbiter and interface to the UART DMA request signals is described in detail.

- A. Design Considerations
- B. DMA Request Enable
- C. DMA Request Prioritization
- D. Arbitration Vector Selection
- E. Local Arbiter
- F. Fairness
- G. Terminal Count Interrupt

SOFTWARE

- A. Programming the Micro Channel DMA Controller
- B. Driver Programs

EISA BUS DESIGN COMPARISON

Brief description of a possible EISA bus serial port/DMA design.

APPENDICES

- A. ADF Listing (@6e6D.adf)
- B. PAL® Equations

APPENDICES (Continued)

- C. Schematics
- D. Layout Drawing
- E. Bill of Materials

INTRODUCTION

The PC16552C integrates two NS16550AF UARTs into a single package. The product provides control for two independent PC-AT® and PS/2® compatible serial ports. In addition, the on-board FIFOs and DMA request strobes of the PC16552C create the basis for a high-performance serial port design.

Advancing modem technology is causing a substantial increase in serial transfer baud rates, putting a severe strain on existing serial port designs. Personal computer systems are unable to keep up with transfer rates that are now reaching 115k baud. The PC16552C allows the serial port designer to design ports that can handle these faster data rates. Transmitter and Receiver FIFOs buffer up to 16 bytes of data each, and request strobes signal the system DMA controller to transfer data to empty transmitter FIFOs and from full receiver FIFOs. DMA burst transfers can move data from the serial I/O ports to system RAM very quickly with no latency time and no attention from the system CPU.

This document contains a user's guide for the adapter and discusses the considerations involved in designing any Micro Channel Adapter equipped with a DMA slave. It gives an overview of the Micro Channel POS mechanism, adapter interface and bus arbitration system. The design of the PC16552C Serial/DMA Adapter, intended as an example of a DMA slave serial adapter, is described in detail. A description of the software necessary to facilitate four simultaneous file transfers serviced by the Micro Channel DMA controller is also included.

PC16552C ADAPTER FEATURES

- Two independent PC-AT and PS/2 compatible serial ports with FIFOs capable of running all existing NS16450 and NS16550AF software.
- All configuration done through POS mechanism. No hardware jumpers or switches.
- Serial ports relocatable to all eight standard I/O addresses.
- Serial interrupts available on IRQ3 and IRQ4.
- Hardware interface between UART FIFO DMA requests and the Micro Channel bus arbitration and DMA system.
- POS configurable priority levels for UART DMA requests.
- Support for software enable/disable of UART DMA requests.
- POS configurable Fairness feature for UART DMA requests.
- Automatic interrupt generation and DMA request disable upon receipt of DMA Terminal Count.
- Two DB-9 connectors for the two RS-232 compatible serial ports.

PC16552C Adapter Block Diagram

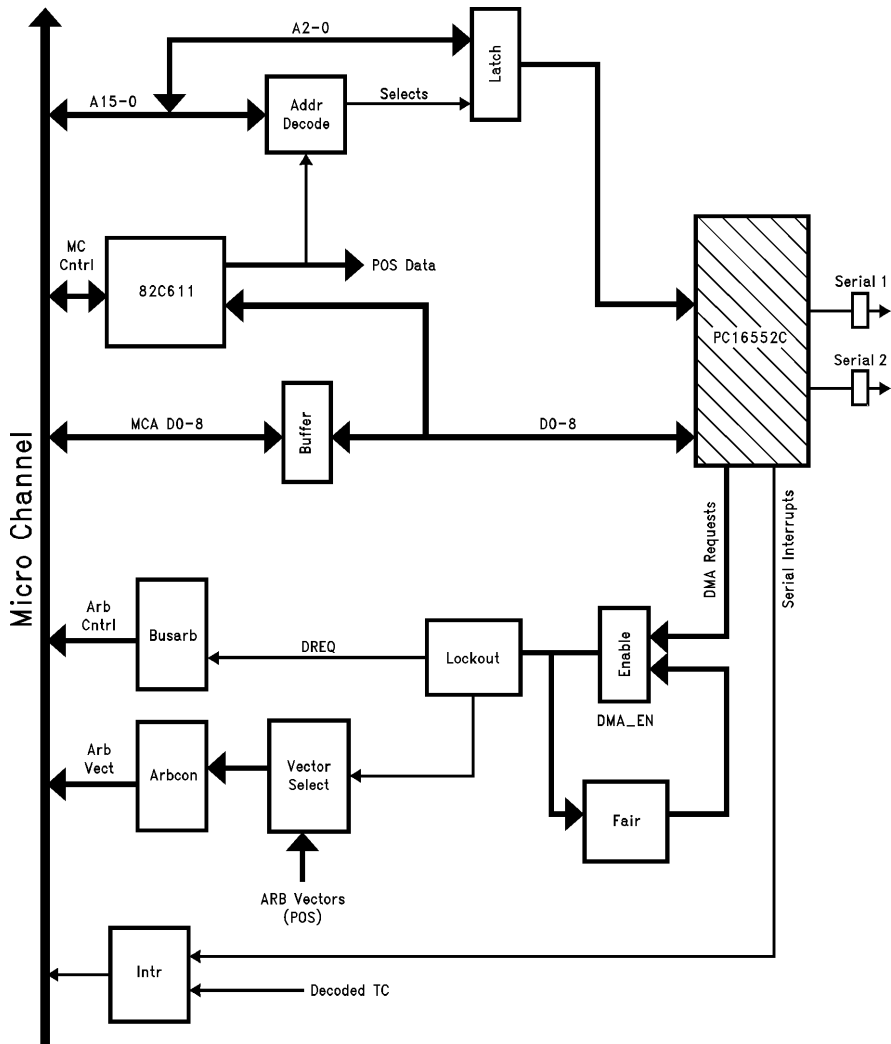

TL/F/11195-1

PC16552C ADAPTER USER'S GUIDE

The PC16552C Adapter comes with a 3 1/2" diskette which contains the ADF file for the adapter. The file is called @6e6d.adf and must be used to configure the adapter. Copy the file onto the Reference Diskette (actually the user's copy of the Diskette) for the machine to be used. To configure the adapter, plug it into an expansion slot and power up the machine with the user's reference diskette inserted in the A drive. The configuration utility is menu driven and is simple to follow. Use the manual configuration to see all the different options available.

The DMA demo programs included on the Adapter's diskette require that it be configured with Channel 1 on COM2 and Channel 2 on COM3. The priority of the DMA requests must be configured with Channel 1 Receiver at level 0 (highest priority), Channel 2 Receiver at level 1 and Channel 1 Transmitter at level 6. The Transmitter for Channel 2 defaults to level 7. The Fairness feature should be enabled at all times except for evaluation purposes.

When the card has been configured and the configuration has been saved to the system's CMOS RAM, remove the Reference Diskette and reboot. The two serial ports may then be evaluated and tested as any other 16550AF port would be tested. To demonstrate the DMA transfers, run the included sample demo programs.

POS—PROGRAMMABLE OPTION SELECT

A unique feature of Micro Channel machines is their Programmable Option Select, known as POS. POS eliminates switches and jumpers from adapter cards by replacing their function with programmable registers. The POS registers allow the system microprocessor to poll each adapter card to determine its characteristics as well as write configuration data to it. All resources required by an adapter (memory and I/O addresses, interrupts used, DMA arbitration vectors, etc.) can be relocatable and reconfigurable by the POS system. Additionally, each card stores in POS registers a unique ID number that the POS system uses to identify the cards present in the system. A full understanding of the POS mechanism is necessary before an adapter design is undertaken. The IBM Technical Reference Manuals provide details about POS that this document may not provide.

POS Mechanism

Each connector slot in the Micro Channel has a unique signal called `CDSETUP` that when asserted, puts the card resident in that slot in setup mode. The setup mode allows access to a block of 8 POS registers located at I/O addresses 100h-107h. All cards in the system locate their POS registers in this space but since only one card can be placed in setup at a time, no conflicts can occur.

Micro Channel machines store in battery-backed CMOS RAM the ID numbers of all resident adapters, the slot numbers they're plugged into and the configuration data to be written to their respective POS registers. During Power On Self Test (POST), the system microprocessor puts each slot in turn into setup mode and reads its ID. If it finds a valid ID it sends the card its configuration data. If there is no card in a slot, the microprocessor will read an ffh which it recognizes as an empty slot.

Since the system remembers which adapter and ID resides in each slot, removing a card, inserting a new card, or even moving an existing card to a different slot will cause a POST failure. IBM's System Configuration utilities must then be run to reconfigure the system by modifying the configuration data stored in CMOS RAM.

ADFs—Adapter Description Files

System board and adapter POS data is also stored on the Reference diskette in the form of Adapter Description Files. ADFs are given names corresponding to the ID of the card it is to configure. The PC16552C Adapter has an ID number of 6E6Dh, giving it an ADF name of @6E6D.adf. A listing of @6E6D.adf is included with this documentation.

The ADF is divided into sections which each list one or more choices of resources to be allocated to the adapter card. A given choice specifies the data to be loaded into a particular POS register and also lists the resources allocated. For example, in @6E6D.adf, choosing "Serial 2" (COM2) for connector 1 will reserve the I/O address space 2f8-2ffh and will notify the system that IRQ3 is used. It also specifies the data to be written to some of the bits in POS registers 102 and 103. Note that pos[0] denotes POS102 and pos[1] denotes POS103 because registers POS100 and 101 contain the read-only card ID bytes which are not referred to in ADFs. See PC16552C Adapter POS Register Description for a description of the contents of the registers used in this adapter.

The syntax for the ADF is straight forward and described in detail in IBM's Technical Reference manual. However, the Configuration utilities are unforgiving of errors. Any errors in a designer's ADF will prevent any POS data for that card from being loaded and the card from being enabled for operation. In addition, the system will not boot to the operating system while the new card is inserted until the ADF is correct and the system has been reconfigured with the new data. One undocumented idiosyncrasy involves the 4-bit fields for arbitration vectors. Since the system DMA controller only recognizes vectors 0-7, only 3 bits are needed to specify the vectors to be used on the card. However, the Configuration utilities required that all four bits be specified, including the most significant bit which is always 0.

Configuration Utilities

There are two different utilities on the Reference diskette provided with the system which actually convert the ADFs to configuration data in CMOS RAM. One of these utilities must be run whenever a new card is installed. The first is the Automatic Configuration program. It takes the first choice in each resource list that will not cause a conflict with other adapters in the system and automatically stores the corresponding POS register data in CMOS RAM.

The second program is Set Configuration which allows the user to manually select the resources desired. It first reads the configuration data already in CMOS RAM and displays the resources allocated to each installed card. It then allows the user to change these choices of resources by displaying one-by-one all of the options for that adapter listed in the ADFs. After all new choices have been made, exiting the program causes the new POS data to be loaded into CMOS RAM and the system is reconfigured and re-booted.

POS Registers

Address (hex)	Function
0100 (POS Register 100)	Adapter Identification Byte (LSB)
0101 (POS Register 101)	Adapter Identification Byte (MSB)
0102 (POS Register 102)	General Option Select Data
0103 (POS Register 103)	General Option Select Data
0104 (POS Register 104)	General Option Select Data
0105 (POS Register 105)	General Option Select Data
0106 (POS Register 106)	Sub Address Extension (LSB)
0107 (POS Register 107)	Sub Address Extension (MSB)

Registers 100 and 101 are read-only and registers 102–107 are read and write. The ID registers are required on all adapters, but all bits in registers 102–105 are optional and user-defined except for the following:

- 102 Bit 0: Card Enable (CDEN): This bit must be implemented and is used to enable the entire adapter card. It is set last during POS initialization and only if the card will not produce any resource conflicts. The CDEN signal gates the decode of all addresses used on the adapter as well as any interrupt requests.
- 105 Bit 7: Channel Check Active Indicator. This bit is required only by adapters which generate CHCK errors (see Micro Channel Interface Control Signals). Error handlers need this bit to identify the source of the error signal.
- 105 Bit 6: Channel Check Status Indicator (STAT). This bit is also required only by adapters supporting CHCK. It is used to indicate that channel check status information is available in POS106 and 107.

PC16552C Serial/DMA Adapter

POS Register Description

The Chips and Technologies 82C611 Micro Channel Interface IC, used to simplify the interface between the PC16552C Adapter and the Micro Channel, provides good POS register support. For all 8 POS registers, the 82C611 can be configured to generate read and write strobes for externally implemented registers or can implement registers internally. The 82C611 defines how several of the POS bits used in this adapter were assigned. As can be seen in the following register descriptions, some bits are available on external pins while others are used for internal address decoding or to define the operating modes of the 82C611.

POS100 and POS101—Adapter ID Bytes

All adapters must store a two-byte ID number in POS registers 100 and 101. IBM specifies that all direct program control adapters (including memory-mapped I/O) have an ID byte between 6000 and 6FFFh. As previously mentioned, the ID byte for this adapter is 6E6DH. When POS100 and 101 are read during setup, the 82C611 produces two sepa-

rate read strobes— $\overline{100RD}$ and $\overline{101RD}$. These signals, as well as their logical AND, are used by the INTR PAL to pull down the data bus bits necessary for the CPU to read back 6D from POS100 and 6E from POS101 (see INTR.ABL for equations). The data bus is pulled up to insure legal high levels on bits not driven low.

6E6D has been registered at IBM and is guaranteed not to conflict with any other legitimate adapters. The number to call to register an ID is 800-426-7763. It is a good idea to find out what numbers are available before implementing it in a design as many numbers are already reserved. Numbers that minimize the logic necessary to implement them have as few logic 0 bits as possible and also have low and high order bytes that have 0 bits in the same position.

POS102

This register is internal to the 82C611 and has all 8 bits brought out to pins POS102B1–7 and CDEN. It is programmed as follows:

102B7: Fairness: (Used to enable IBM's Fairness algorithm. See DMA INTERFACE.)

102B6: A7*A6*A4

102B5: A8

102B4: A3

(Address bits providing decode information for UART channel 1.)

102B3: A7*A6*A4

102B2: A8

102B1: A3

(Address bits providing decode information for UART Channel 1.)

102B0: CDEN: (See POS Registers.)

POS103

This register is internal to the 82C611. The bits are not available on external pins but instead are compared to 3 input pins which are connected to address bus bits 14, 13 and 12. A match produces an output used for the decode of the UART channels.

102B7: unused

102B6: unused

102B5: A14

102B4: A13

102B3: A12

(Address bits providing decode information for UART channel 1.)

102B2: A14

102B1: A13

102B0: A12

(Address bits providing decode information for UART channel 2.)

POS104

This register stores the bus arbitration vectors for the UART receiver DMA requests $\overline{RXRDY1}$ and $\overline{RXRDY2}$. It is implemented externally using a 74LS374 latch and 74LS245 buffer. The 82C611 decodes reads and writes to the register during setup and provides the correct strobes. This information is also needed as external signals so they were implemented in a register with corresponding output pins.

102B7: RX2 ARB3
102B6: RX2 ARB2
102B5: RX2 ARB1
102B4: RX2 ARB0
102B3: RX1 ARB3
102B2: RX1 ARB2
102B1: RX1 ARB1
102B0: RX1 ARB0

POS105

This register is implemented internal to the 82C611. The lower four bits contain the arbitration vector for UART channel 1 transmitter. They were selected for the vector because output pins were needed. The upper four bits contain control bits for the Micro Channel interface.

105B7: Channel Check Active Indicator. See POS registers. It is not used in this adapter.

105B6: Channel Check Status Indicator (STAT). See POS Registers. It is not used in this adapter.

105B5: Synchronous Extended Mode: The 82C611 specifies the definition of this bit. It generates synchronous extended cycles if set and asynchronous extended cycles if cleared (see \overline{CHRDY} in Micro Channel Control Signals).

105B4: unused

105B3: TX1 ARB3
105B2: TX1 ARB2
105B1: TX1 ARB1
105B0: TX1 ARB0

POS106 and **POS107** are not used in this adapter. The sub-addressing bits are used to specify the location of a block of initial program load (IPL) or additional setup information.

MICRO CHANNEL BUS INTERFACE

Micro Channel Control Signals

All of the Micro Channel signals needed to control an 8- or 16-bit adapter are described below. They are all connected directly to the 82C611 which meets all IBM timing and drive specifications for those signals.

CD SFDBK: Card Selected Feedback: This signal must be driven low by an adapter to acknowledge to the system when it decodes a specified address. The 82C611 drives this signal low when the adapter logic asserts the part's CDSSEL input. The CDSSEL signal is generated by a logical OR of the unlatched address decodes of both UART channels and the two registers decoded on the adapter for DMA control and status (see DMA Interface Design).

CD DS16: Card Data Size 16: This signal is driven low when an adapter requires a 16-bit data transfer. The 82C611 drives this signal as a function of its DS16 input which is tied high in this design.

CD CHRDY: Card Channel Ready: An adapter which needs more time to transfer data on the Micro Channel pulls this signal low (not ready) to extend the current bus cycle. There are two types of extended cycles: Asynchronous Extended and Synchronous Extended. The difference between them is when the CD CHRDY signal driven back high (ready). In the synchronous case, CD CHRDY is removed within 30 ns of the falling edge of \overline{CMD} . This causes the system to extend the cycle 100 ns or 1 wait state. In the asynchronous case, CD CHRDY is removed at any time by the adapter providing as many wait states as necessary (the limit for holding CD CHRDY low is 3 μ s). POS105 bit 5 defines which type the 82C611 supports. A single wait state is needed to support DMA transfers from the PC16552C so the bit is programmed for synchronous mode. The 82C611 causes an extended cycle when its \overline{ADPRDY} signal is asserted by the adapter. In this design, the \overline{ADPRDY} signal is the same as the CDSSEL signal thus causing an extended cycle to be generated on every access to the Adapter.

CHRESET: Channel Reset: This active high strobe from the Micro Channel resets devices on adapter cards. It is connected to the 82C611, PC16552C, and the Busarb, Lockout and Fair state machines.

CD SETUP: Card Setup: The Micro Channel drives this signal low during POS setup. Upon receiving this signal, the 82C611 places the PC16552C Adapter into setup mode by allowing access to the POS registers.

REFRESH: This system indicates through this signal that a refresh cycle is occurring on the bus. The refresh cycle looks like a normal memory read, which the 82C611 will ignore upon receiving an active $\overline{REFRESH}$ signal.

CHCK: Channel Check: Adapters assert this signal to indicate a serious error (such as parity) which threatens system operation. The signal is common to all adapter slots so it must be driven with an open-collector driver. The 82C611 drives this signal as a function of the ERROR input which is tied high (inactive) in this design.

$\overline{S0}$, $\overline{S1}$, $\overline{M/IO}$ and \overline{CMD} : The 82C611 decodes these signals into separate I/O read (IOR) and I/O write (IOW) strobes.

Data Bus

A 74LS245 buffer isolates the Adapter's data bus from the Micro Channel data bus to prevent excessive loading of Micro Channel bus. Direction and gating during read and write cycles is controlled by the 82C611's BUFDIR and BUFENL signals. The internal bus connects to the PC16552C, POS104, DMA__EN and ISR registers (see DMA Interface) and the INTR PAL (POS ID generator).

Address Decode

Micro Channel adapters should have their resources relocatable and selectable through the POS mechanism. This design allows for the two serial channels on board the PC16552C to be located at any two of the 8 "standard" IBM serial port addresses. The following table shows those addresses:

COM Port	Hex Address	Binary Address (A15-0)
1	03F8	0000 0011 1111 1000
2	02F8	0000 0010 1111 1000
3	3220	0011 0010 0010 0000
4	3228	0011 0010 0010 1000
5	4220	0100 0010 0010 0000
6	4228	0100 0010 0010 1000
7	5220	0101 0010 0010 0000
8	5228	0101 0010 0010 1000

The upper 13 bits of the address must be decoded while the lower 3 bits, A2-A0, connect directly to the PC16552C to select one of 8 internal registers of the selected channel. As can be seen from the binary addresses above, 5 bits stay the same for the 8 COM ports (A15, A11, A10, A9, A5) and 8 bits must be programmed for the port selected for decode.

Adapter card logic gates "compress" bit fields that are always at the same logic level so that all 13 bits will not need to be decoded separately. The 82C611 has inadequate address decoding resources so two 74LS521 Comparators, one for each UART channel, are implemented to compare compressed bits and some of the address bus bits with POS programmed bits and hard-wired bits. POS registers 102 and 103 are programmed with the data necessary to decode the two ports selected for use on the adapter (see POS Register Description). The entire decode works as follows:

Address bits A15, A11 and A10 are always 0. They are compressed to one bit with a NOR gate and compared to a hard-wired 1 on both comparators.

A9 and A5 are always 1. They are compressed by a NAND gate to a bit which is compared to a hard-wired 0 by both comparators.

A7, A6 and A4 are all 0 if the port address is for COM3-8. A NAND gate compresses the bits to a signal which is compared to POS102 bit 6 by the channel 1 comparator and to POS102 bit 3 by the channel 2 comparator. Thus POS102 bit 6 must be programmed to a 0 if channel 1 is to be COM1 or COM2 and to a 1 if it's to be COM3-8. POS102 bit 3 is programmed similarly for channel 2.

A8 is a 1 in the COM1 address and 0 in all others. It is connected directly to both comparators and compared to POS102 bit 5 and POS102 bit 2 which are programmed for channel 1 and channel 2 respectively.

A3 equals 1 in COM1, 2, 4, 6 and 8 and equals 0 in COM3, 5 and 7. It is also connected directly to each comparator and compared to POS102 bit 4 and bit 1 which are programmed for channel 1 and channel 2 respectively.

A14, A13 and A12 are connected to 82C611 multi-function pins MFP6, 5 and 4 respectively. They are constantly compared to two bit fields in POS103-B5-3 and B2-0. Bits 5-3 are programmed with the A14, A13 and A12 bits expected for channel 1 and bits 2-0 with the bits expected for channel 2. The 82C611 will assert $\overline{MFP3}$ when a match is made for channel 1 and will assert $\overline{MFP2}$ when a match is made for channel 2. $\overline{MFP3}$ is connected to the channel 1 comparator and $\overline{MFP2}$ is connected to the channel 2 comparator. Both are compared to a hard-wired 0.

As stated in the POS Register Description, POS102 bit 0 is the card enable signal CDEN. The signal enables UART address decode by being compared to a hard-wired 1 on both comparators (CDEN is 0 until POS102 bit 0 is set). Finally, the M/IO signal from the Micro Channel is used to gate both LS521 comparators so that only I/O addresses are decoded. The two comparators produce active low outputs when an address match is found. These signals are $\overline{CS1}$ and $\overline{CS2}$, the selects for the PC16552's two channels.

The adapter decodes one additional I/O address, 2F7h, which is the location of the write-only DMA_EN register and read-only ISR register (see DMA Interface for register description). These registers are not relocatable. However, the I/O resource is "claimed" in the adapter's ADF so any conflict with other cards will be caught by POST which will not enable the card, preventing system damage.

UART Interface

The PC16552C register address bits (A2, A1, A0) and the \overline{CS} outputs of the LS521 comparators are latched into a 74LS373 by the \overline{CMD} signal and held for the duration of a bus cycle. The latched $\overline{CS1}$ and $\overline{CS2}$ signals are ANDed to produce the PC16552's \overline{CS} signal. The correct channel on the UART is selected by connecting the $\overline{CS2}$ signal to the UART's CHSL input which produces the following channel decode:

$\overline{CS1}$	$\overline{CS2}$ (CHSL)	Channel Selected
0	1	1
1	0	2
1	1	X

The adapter's address decode logic and the PC16552C cycle time is fast enough to operate with the Micro Channel's default bus cycle length. No wait states are needed for access to the UART.

Interrupts

The Micro Channel's IRQ interrupts are designed as active-low, level-sensitive signals. This simplifies adapter interrupt sharing logic and reduces transient sensitivity on the interrupt controller while retaining compatibility with existing software. Because IRQ lines are shared, open-collector drivers or active-low TRI-STATE® drivers must be used by adapters to drive the lines.

The INTR GAL® on the PC16552C Adapter drives the IRQ3 and IRQ4 signals. INTR inputs the interrupt signals from the PC16552C (INTR1 and INTR2) and the TC interrupt (see DMA Interface). INTR will assert IRQ3 if a TC interrupt is generated or if a UART channel configured as COM2–8 generates a serial interrupt. It will assert IRQ4 if it receives a serial interrupt from a channel configured as COM1. INTR decodes the serial interrupts by using POS102 bits 5 and 2 which store address bit A8 for channels 1 and 2 respectively. A8 is used because it is a 1 if COM1 is being used and a 0 if any other COM port is used. See the included INTR.ABL listing for the GAL equations.

MICRO CHANNEL BUS ARBITRATION

The PC16552C Dual Serial/DMA Adapter implements the logic necessary to interface a DMA slave device to the Micro Channel's bus arbitration system and DMA controller. A DMA slave adapter must contain a Local Arbiter, as defined by IBM, in order to compete for the bus and communicate with the system's Central Arbiter. The adapter must also contain any logic necessary to directly support the device requesting DMA service.

The following material on the DMA Interface discusses the function of the Central Arbiter and the bus arbitration process, Local Arbiters and DMA interface design considerations. It then describes in detail the functions of the DMA interface logic implemented on the PC16552C Adapter.

Central Arbiter

The Central Arbiter exists on all of IBM's Micro Channel machines and gives intelligent subsystems the ability to share and control the system. It supports up to 16 arbitrating devices, such as a DMA slave, a bus master and the system microprocessor.

The Central Arbiter is located on the system board of the Micro Channel machines and uses seven Micro Channel signals to control arbitration between devices. The seven signals are $\overline{\text{PREEMPT}}$, ARB/GNT, $\overline{\text{BURST}}$ and ARB3–0. ARB/GNT may only be driven by the Central Arbiter. The rest of the signals may be driven by any device on the Channel and therefore must be connected to open-collector drivers.

Any device requesting control of the bus asynchronously drives $\overline{\text{PREEMPT}}$ active. The Central Arbiter responds by initiating an arbitration cycle after the device currently using the Channel has completed. The Central Arbiter indicates the arbitration cycle by driving the ARB/GNT signal high into the arbitration state. Requesting devices then drive their assigned 4-bit arbitration vector onto the ARB3–0 bus. These vectors are prioritized with 0000 being the highest and 1111 being the lowest priority. Each competing device compares the vector it is driving onto the ARB pins with the level already on the bus. If it finds a level that has a higher priority it stops driving its vector onto the bus, thus leaving the highest priority vector on the bus. When the Central Arbiter ends the arbitration period by changing the ARB/GNT signal to the grant state, the device driving the winning vector assumes control of the bus.

Devices requiring multiple data transfers must notify the central arbiter by driving the $\overline{\text{BURST}}$ signal until all transfers are complete. A bursting device may also stop transfers

if another device drives $\overline{\text{PREEMPT}}$ active, thus postponing any further transfers until it wins the system channel again. IBM® requires a bursting device not to ignore an active $\overline{\text{PREEMPT}}$ for more than 7.8 μs (thus 7.8 μs is the maximum time allowed for a single BURST transfer). At this time the Central Arbiter forcibly takes control away from the bursting device by raising the ARB/GNT signal. The system will also generate an error indication and NMI.

The Central Arbiter recognizes the end of a transfer when both status signals ($\overline{\text{S0}}$ and $\overline{\text{S1}}$) are inactive (signifying the end of a bus cycle) and $\overline{\text{BURST}}$ or $\overline{\text{CMD}}$ go inactive, whichever occurs last. Arbitration then begins for the next highest priority requesting device. The system CPU, which is assigned the lowest priority arbitration vector 1111, will resume control of the system bus if no other devices are requesting the bus.

A programmable (through POS) fairness feature prevents high priority devices from locking out lower priority devices. If fairness is active, a device that has control of the bus cannot compete again for the bus until all other competing devices have been allowed to run their cycles. This ensures that all arbitrating devices will be serviced in order of priority before the same device can gain control of the channel again.

The system DMA controller is an integral part of the Central Arbiter. The controller has 8 channels (0–7) which correspond to arbitration vectors 0000–0111. A device requesting DMA service competes for the system bus with the vector corresponding to the DMA channel previously programmed to perform the desired transfer. The DMA controller assumes control of the bus when the highest priority requesting DMA wins the arbitration cycle. The controller will execute single byte transfers unless the DMA slave asserts the $\overline{\text{BURST}}$ signal. In this case, the controller will execute a burst cycle, executing transfers until the $\overline{\text{BURST}}$ signal is deasserted or the controller's Terminal Count (TC) is reached. See the Software section of this document for details on the operation and programming of the DMA controller.

Local Arbiter

Devices requesting control of the Micro Channel must implement logic known as a Local Arbiter. The Arbiter logic must drive the arbitration bus in a manner that allows all competing devices to recognize a winner.

When the Central Arbiter starts an arbitration, a competing local arbiter drives its vector onto the ARB bus. At the same time, it compares that vector to the value appearing on the bus on a bit-by-bit basis beginning with the most significant bit, ARB3. If it finds a mismatch on one of the bits, it will cease driving that bit and all lower order bits. If it subsequently finds a match on that bit, it will continue driving lower order bits until another mismatch is detected. The arbitration bus must be driven by open collector drivers so that multiple devices may drive the bus and compete for service. The following is an example of a bus arbitration:

1. Devices A and B, with arbitration levels 1001 and 0110 respectively, compete for the channel. Both devices drive their vectors onto the ARB bus which then appears as 0000.

2. Device A detects a mismatch on ARB3 so it ceases driving all lower order bits. Device B sees a mismatch on ARB2 so it stops driving its lower order bits. The bus now shows 0111.
3. Device B now sees a match on ARB2 so it continues to drive its lower order bits (only ARB0 in this case).
4. The bus now stabilizes at a value of 0110 and device B has won control of the channel.

PC16552C ADAPTER DMA INTERFACE DESIGN

Design Considerations

The PC16552C Adapter contains not one but four independent devices which may request DMA service. These “devices” are the four on-board FIFOs (two Transmit and two Receive). Each FIFO has an independent request signal which indicates when it is empty (transmitters) or when it is full (receivers). These signals are named $\overline{\text{TXRDY1}}$, $\overline{\text{TXRDY2}}$, $\overline{\text{RXRDY1}}$ and $\overline{\text{RXRDY2}}$. This creates some freedom in the design of the interface between the UART requests and the Micro Channel. However, there is a severe timing limitation concerning the termination of a burst cycle that adds constraints to the design.

The design freedom lies in where the competition between the four UART request takes place. One possibility is to have them compete against each at the system level during the central arbitration cycle. This requires the adapter to implement four Local Arbiters, one for each UART request. At the other end of the spectrum, the adapter may implement prioritization logic that allows only one of the requests to compete for the channel at a time. Thus only one Local Arbiter is needed. The designer may also choose a compromise such as prioritizing the receiver and transmitter requests separately and using two Local Arbiters. Using four separate Local Arbiters simplifies the overall design by elim-

inating the UART request prioritization. However, it creates duplication of functionality (the same logic implemented four times) and will generate a higher component cost. The PC16552C Adapter is designed with the latter implementation.

One particular timing specification required by the Micro Channel when a DMA slave terminates a burst cycle is the most critical issue in the design of a useful DMA-serviced serial port. The goal of the DMA interface design is to be able to transfer four files simultaneously in two directions with attention from the CPU only at the beginning and end of the file transfers. This can only be accomplished by continually performing FIFO-sized burst transfers (16 bytes) in response to UART FIFO requests until the DMA controller reaches its programmed Terminal Count (end of the file). This type of operation is called slave-terminated burst mode and requires the UART to terminate a burst as soon as its FIFO has been filled or emptied by the controller.

DMA controller-terminated transfers can also be used but requires the DMA controller to be programmed with the number of bytes to be transferred to or from a FIFO instead of with the total number of bytes in a file. The controller must be reprogrammed after every transfer which requires much more attention from the CPU than with slave-terminated transfers.

When the DMA controller writes the byte that fills a Transmit FIFO or reads the last byte in a Receiver FIFO, the PC16552C deasserts the appropriate DMA request. The request signal passes through the logic on the adapter and deasserts the $\overline{\text{BURST}}$ signal. The Micro Channel specifies a minimum time that $\overline{\text{BURST}}$ be inactive high before the end of a bus cycle in order to stop a burst without an additional byte transfer. This is the critical timing issue. The timing diagram in *Figure 1* illustrates the signals and delays involved.

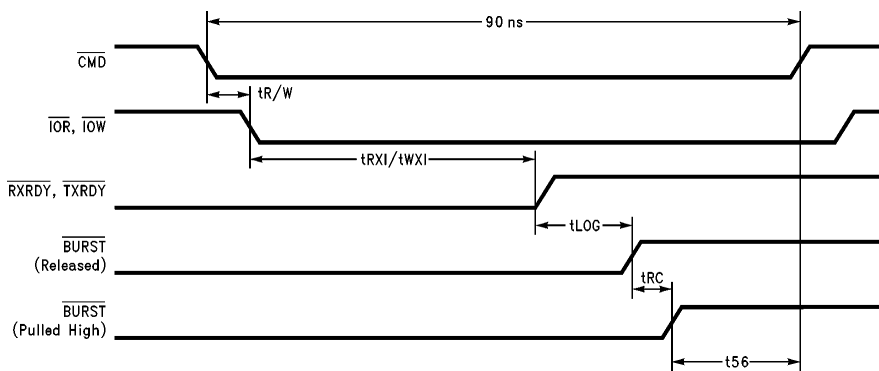

TL/F/11195-2

Timing Parameters:

tR/W: Time to decode S0, S1 and M/IO signals into IOR and IOW strobes.

tRXI/tWXI: $\overline{\text{RXRDY}}/\overline{\text{TXRDY}}$ inactive from leading edge of read and write strobes respectively (PC16552C DMA request signal spec).

tLOG: Propagation delay of request signal through logic controlling $\overline{\text{BURST}}$.

tRC: RC restoration of $\overline{\text{BURST}}$ on the Micro Channel.

t56: $\overline{\text{BURST}}$ inactive high setup to $\overline{\text{CMD}}$ inactive—Micro Channel specifies 35 ns minimum.

FIGURE 1

Without extending the bus cycle, the maximum delay time from the leading edge of $\overline{\text{CMD}}$ to $\overline{\text{BURST}}$ inactive is 55 ns. The two delays which must be minimized in the DMA interface design are $t_{\text{RXI}}/t_{\text{WXI}}$ and t_{LOG} . $t_{\text{RXI}}/t_{\text{WXI}}$ are controlled by the PC16552C and t_{RC} is created by the Micro Channel. It is a quantity that is unknown to this designer as it is not specified in the IBM Technical Reference Manual.

The PC16552C $\overline{\text{TXRDY}}$ signals were designed to be released by the rising edge of the last IOW strobe. This makes it impossible to meet the $\overline{\text{BURST}}$ inactive setup time and therefore perform slave-terminated bursts. The PC16552C has since been redesigned so that $\overline{\text{TXRDY}}$ is released by the $\overline{\text{RXRDY}}$ signals. The RXTXI.C driver program included in this package uses DMA controller terminated burst transfers for the transmitter FIFOs, a method which must be used with the older revision of the PC16552C. The new revision of the PC16552C was not available when this documentation was completed. However, slave-terminated transfers were run with the old revision and the adapter performed correctly except that due to the lateness of the $\overline{\text{BURST}}$ deassertion, a 17th byte was always transferred to the transmit FIFO. The last byte was lost since the FIFO was already full. Therefore, the RXTXI.C driver program should be used with all current PC16552C parts.

A second issue with the PC16552C is the length of both t_{RXI} and t_{WXI} which are specified as 78 ns and 60 ns (max). These times plus the delays in the logic implemented on this adapter forces the use of an extended cycle (wait state). Using the Synchronous Extended cycle as explained in the Micro Channel Control Signals section, adds 100 ns to the length of the $\overline{\text{CMD}}$ strobe, providing enough time to meet the $\overline{\text{BURST}}$ inactive specification.

Adding a wait state is obviously undesirable since it increases the bus cycle length by 50% (200 ns to 300 ns). One way for a designer to avoid needing a wait state is to minimize t_{LOG} and $t_{\text{R/W}}$. Besides using fast logic, the delay through the DMA logic interface can be reduced by implementing the design with four Local Arbiters. This eliminates the delay created by the prioritization of the UART requests. Also, an effort is being made to reduce the t_{RXI} and t_{WXI} specs on the PC16552C. Finally, the IBM documentation is not clear as to whether the t56 spec must be met for both IO read/memory write and memory read/IO write transfers. The spec is marked on the timing diagrams for both types of transfers, but a separate note says that the spec must be guaranteed for IO write cycles with no mention of the IO read cycles. It is likely that the spec need not be met for IO read cycles because the read to the IO device occurs long before the end of the byte transfer since the byte must still be written to memory.

While it did not meet worst-case specifications, the PC16552C Adapter (with the old PC16552C rev) was also tested without a wait state and ran I/O read DMA transfers without errors. A test of the IO write transfers was futile because only the older PC16552C was available making slave-terminated transfers impossible.

The design chosen for implementation uses just one Local Arbiter and prioritizes the UART DMA requests on the adapter. This design was chosen because it is more inform-

ative example and has a lower chip count. This section describes the following functions of the interface logic: enable/disable of UART DMA requests; prioritization of the four DMA requests; selection of the proper arbitration vector; local bus arbitration; fairness and Terminal Count interrupt generation. Refer to the block diagram and schematics for the PC16552C Adapter during the following discussions.

DMA Request Enable

A 4-bit write-only DMA request enable/disable register (DMA__EN) is implemented on the PC16552C Adapter using four 74LS74 latches. The complemented outputs of the latches are used to gate the PC16552C's DMA request signals $\overline{\text{RXRDY}}$ and $\overline{\text{TXRDY}}$. To enable DMA request signals, the system CPU must write a 1 to the bit locations corresponding to those requests. Table I summarizes the register's function.

TABLE I

DMA—EN Bits								
7	6	5	4	3	2	1	0	
X	X	X	X	0	0	0	0	All DMA Request Disabled
X	X	X	X	0	0	0	1	$\overline{\text{TXRDY2}}$ Enabled
X	X	X	X	0	0	1	0	$\overline{\text{TXRDY1}}$ Enabled
X	X	X	X	0	1	0	0	$\overline{\text{RXRDY2}}$ Enabled
X	X	X	X	1	0	0	0	$\overline{\text{RXRDY1}}$ Enabled

DMA__EN is necessary to prevent errant DMA requests to the Micro Channel (such as the immediate transmitter requests after reset) and to maintain compatibility with standard CPU-serviced serial port operation. A hardware disable is also implemented and is described in the TC Interrupt section.

DMA__EN is located at I/O address 2F7h. This location is not used by IBM and was chosen because of its similarity to the COM2 address block made the decode simpler. The active low output of the register's address decoder is gated with the IOW signal to produce a write strobe to the CLK inputs of the 74LS74 latches.

DMA Request Prioritization

If the adapter card is used at its full capability i.e. four simultaneous DMA-serviced file transfers, the four UART DMA request strobes will operate as fully independent, asynchronous signals. The asynchronous state machine, Lockout, implemented in a 16L8D GAL, is used to select the highest priority active DMA request and lock out all other requests until that request has been serviced. The state diagram for Lockout is illustrated in *Figure 2*. The state machine resides in the Idle state until one or more DMA requests go active. The requests are the active high gated versions of the $\overline{\text{RXRDY}}$ and $\overline{\text{TXRDY}}$ signals and are called RX1, TX1, RX2, and TX2. An active request moves Lockout to the corresponding request state. If more than one request are active at once, the machine will move to the highest priority state. The requests are prioritized as follows: RX1 (highest), RX2, TX1 and TX2. Note that this prioritization mechanism provides adapter-level arbitration between the requests leaving only one which competes for the bus at the system level (Central Arbitration).

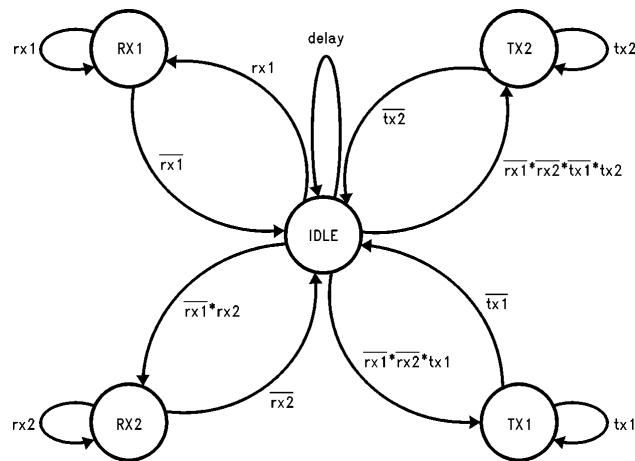

TL/F/11195-3

FIGURE 2. Lockout State Machine

Upon entering a request state, Lockout asserts the \overline{DREQ} signal and a 2-bit code, S1 and S0 (not to be confused with the bus signals S1, S0) corresponding to the request selected. The machine remains in the request state until the corresponding request signal goes inactive signifying the end of the DMA service. It then moves back to the idle state, deasserts \overline{DREQ} and waits for a new request.

A delay feature was implemented to handle two or more requests active at one time. Without this delay, the machine would move very quickly from a request state, through the Idle state and into the next highest priority request state. The result is that the \overline{DREQ} signal, which is inactive only while in the Idle state, does not go inactive long enough to cause a state change in the Busarb state machine (see Local Arbiter). BUSARB must change states so that it can signal the end of a transfer to the DMA controller by deasserting \overline{BURST} . The Delay input to the Lockout machine is the feedback \overline{DREQ} signal, inverted and delayed 100 ns. During a transfer, \overline{DREQ} is active low and the Delay signal is active high. At the end of a transfer cycle, the Lockout machine moves to the Idle state and deasserts \overline{DREQ} . It will stay in Idle until the Delay signal goes inactive low 100 ns later. Thus \overline{DREQ} is guaranteed to be inactive for at least 100 ns.

Selection of Arbitration Vector

The PC16552C Adapter is designed to store four different arbitration vectors which correspond to the 4 DMA channels programmed to service the UART's \overline{RXRDY} and \overline{TXRDY} DMA request signals. Two 74LS153 Dual 4-Line to 1-Line Data selectors are used to present the proper vector to the Arbcon PAL for arbitration (see Local Arbiter). The S0, S1 outputs of Lockout are connected to the select inputs of the Data Selectors. The data inputs to the selectors are the outputs of the POS registers holding the arbitration vectors. Note, however, that in this design the vector for \overline{TXRDY} is hardwired to 0111, the lowest priority vector, due to lack of POS space. Another POS register could have been added to provide flexibility for the \overline{TXRDY} vector, but would have required additional logic.

Local Arbiter

The PC16552C Adapter implements the Local Arbiter in two PALs, Arbcon and Busarb.

The Arbcon 20L8A PAL implements the vector arbitration function. It competes for the bus with the vector belonging to the UART request selected by Lockout. The ENARB signal from the Busarb state machine gates the vector onto the ARB bus during the arbitration cycle. If the Arbcon logic finds a match between its vector and the ARB bus, it has won the bus and signals to the Busarb machine by asserting \overline{BUSWIN} .

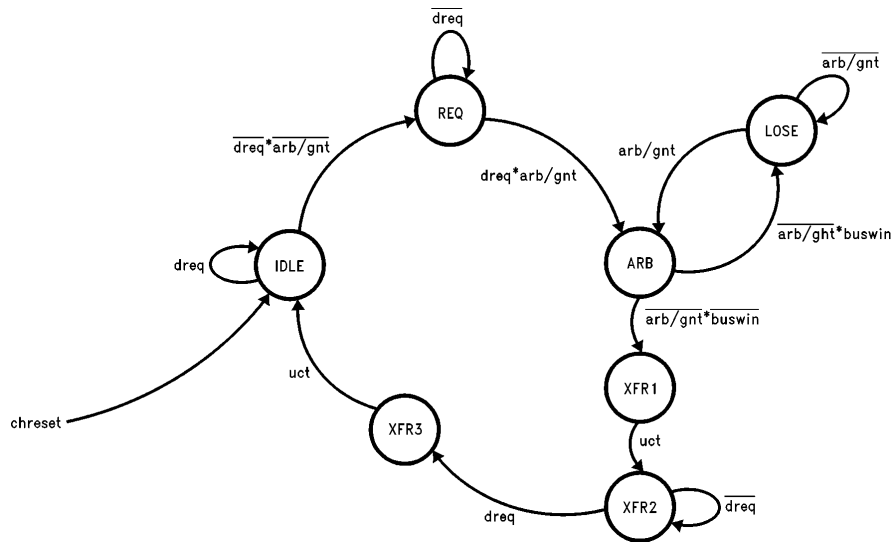

TL/F/11195-4

FIGURE 3. Busarb State Machine

An asynchronous state machine, Busarb, implemented in a 20V8D GAL, controls the bus arbitration. It connects directly to the ARB/GNT, PREEMPT, BURST and CHRESET Micro Channel signals. The following describes Busarb's states and operation. *Figure 3* illustrates the state diagram.

- IDLE: No DMA requests from UART ($\overline{\text{DREQ}} = 1$).
- REQ: UART is requesting DMA service. $\overline{\text{PREEMPT}}$ is asserted to request control of the bus.
- ARB: Central Arbiter has begun arbitration cycle. ENARB is asserted causing Arbcn to start competing for the bus. $\overline{\text{PREEMPT}}$ still active.
- LOSE: Central Arbiter ends arbitration cycle. Arbcn did not win vector arbitration so BUSWIN was not asserted. ENARB is deasserted causing Arbcn to degate its vector. $\overline{\text{PREEMPT}}$ remains active. When the winning device is finished, the Central Arbiter will start a new arbitration cycle and Busarb will move back into the ARB state.
- XFR1: The PC16552C Adapter has won arbitration. This is an intermediate state to XFR2 needed to prevent more than one bit from changing between states. The state transitions from intermediate states (XFR1 and XFR2) are unconditional and marked "uct" on the state diagram. $\overline{\text{PREEMPT}}$ deasserted.
- XFR2: $\overline{\text{BURST}}$ is asserted and DMA controller begins transfer.
- XFR3: $\overline{\text{DREQ}}$ has gone inactive signifying completion of transfer. $\overline{\text{BURST}}$ is deasserted. This is an intermediate state to IDLE.

Fairness

IBM's Fairness algorithm is enabled when POS register 102 bit 7 is set. An asynchronous state machine for each of the four UART DMA request signals, implemented in 2 PALS, Fair1 and Fair2, ensures that the four requests obey the Fairness algorithm by disabling them when Fairness requires them to wait.

All four machines have the same 7 inputs: CHRESET, FAIR, $\overline{\text{PREEMPT}}$ and the four gated UART requests: RX1, RX2, TX1 and TX2. The machines have one unique output, FR, that is a second UART request gating signal along with the DMA_EN output. The Fairness state machines have the following states:

- [1,1] IDLE: Reset state. Particular DMA request (RX1, TX1, RX2, TX2) not active. Output: none.
- [1,0] XFR: DMA request active. Output: none.
- [0,0] FAIR: DMA request goes inactive, FAIR = 1 (enabled) and at least one other UART request or $\overline{\text{PREEMPT}}$ is active. Output: FR degating signal is active.
- [0,1] TEMP: All requests for bus have gone inactive. This is an intermediate state to IDLE. Output: FR still asserted (deasserted upon transition to IDLE).

Figure 4 shows the state diagrams for the RX1 and TX1 state machines. The machines for RX2 and TX2 are identical. On the adapter card, RX1 and RX2 machines are implemented in the 16L8A PAL Fair1 and TX1 and TX2 in Fair2.

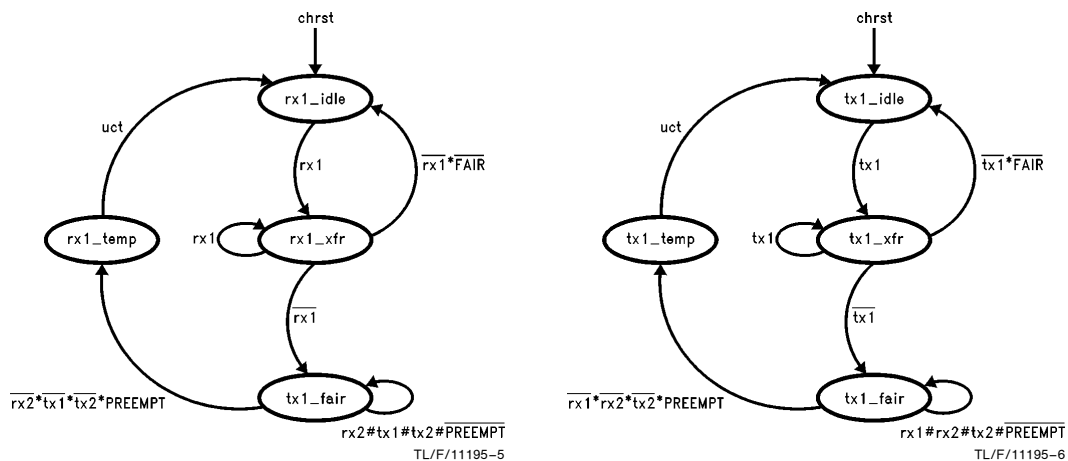

FIGURE 4. Fairness State Machines

All four machines use their particular DMA request signal (RX1, RX2, TX1 or TX2) to move from the IDLE state to XFR to FAIR. But it is all the other request signals that either keep the machine in the FAIR state (if there is at least one active) or allow it to move back to IDLE via TEMP (no other requests active). Thus if a particular channel finishes being serviced and there are others waiting for service at the time, the channel will be degated by its FR signal, preventing it from requesting service again before all other devices—both UART and other bus devices—are finished.

Terminal Count Interrupt

A signal to the CPU that a file or block of data has completed transmission or reception is a crucial feature of a practical DMA-serviced serial port. It is necessary because the entire transfer process is completely transparent to the CPU. The CPU must be notified one or all files being transferred are done so that it can start a new transfer, process received data, notify the user, etc. The DMA controller provides a Terminal Count (TC) pulse when it has transferred the number of bytes programmed into its Terminal Count Register (see Software). The PC16552C Adapter uses this pulse to generate an IRQ3 interrupt and disable the DMA request line of the UART channel that completed its transfer. The TC signal is common to all devices on the Micro Channel so it was necessary to decode the signal and create a TC unique to the UART channel that generated it. Since the DMA controller generates the TC pulse during the final read or write to the I/O address it is servicing, this was accomplished by decoding TC along with the adapter's IOR, IOW, CS1 and CS2 signals. For example, TC, IOR and CS1 active generates TC pulse unique to the UART's channel 1 receiver (RXRDY1).

The channel-unique TC pulses are connected to the \overline{CL} inputs of the DMA_EN register's 74LS74 latches. The TC pulse clears the adapter card enable bit for the decoded channel and prevents any further DMA request from that channel until the CPU has re-initialized the system for a new file transfer.

All four UART TC pulses are OR'ed together to set a 1-bit read-only register called Interrupt Status Register (ISR). The output of ISR is connected to the INTR GAL and generates an IRQ3 interrupt (see Adapter Interrupts). ISR was implemented because the Micro Channel requires that adapters generating interrupts have a status register that the CPU can poll to determine which adapter caused the interrupt.

The ISR is implemented with two 74LS74 latches connected in a master-slave arrangement. This provides a self-clearing mechanism when the register is read. The register is located at I/O address 2f7H along with DMA_EN. Its read strobe is generated by a logical AND of the 2f7H decoder output and the IOR signal. The read strobe is connected to the clock input of the slave latch and the inverted strobe is connected to the master's clock. The strobe is also connected to the gate input of a 74LS125 buffer which gates the output of the slave latch onto the Adapter Data Bus bit 0. The falling edge of the read strobe gates the register onto the data bus and clears the master latch. The rising edge clears the slave latch.

SOFTWARE

Programming the Micro Channel DMA Controller

The Micro Channel DMA controller is register and software compatible with the IBM Personal Computer AT DMA channels, but also has an extended mode of operation. Controller registers can be read and written in the extended mode using two registers, the Function register and the Execute Function register. To perform an extended mode register read/write, the CPU must write to the Function register a 4-bit command code in the upper nibble and the channel number in the lower nibble. The command is executed by reading or writing the Execute Function register. The driver programs included in this package illustrate this register access process.

The most important feature of the extended mode is that it provides access to two new registers: the I/O Address register and the Extended Mode register. The programmer can now use the I/O Address register to specify the address of the I/O port being serviced (the 8237 and therefore the AT machines are not capable of generating this address). The Extended Mode register defines the operation of the channel: Read Memory or Write Memory, Verify or Transfer data, 8-bit or 16-bit transfers and enable/disable of the I/O address generation.

The controller begins the DMA transfers when a DMA slave has won the arbitration bus and the DMA controller has been unmasked and programmed to service the winning request. The controller performs transfers serially with separate read and write cycles for each byte or word transferred. The DMA bus cycles are identical to CPU bus cycles. They may be Default cycles or be extended by the CHRDY signal.

Driver Programs

Two driver programs are included in this package that demonstrate four simultaneous file transfers—RXTX.C, which operates with slave-terminated burst transfers and RXTXI.C, which uses controller-terminated transfers for the serial transmitter channels. Both programs are relatively simple since most of the work is done by the DMA controller, not the CPU.

RXTX.C

RXTX.C performs the following functions:

- allocates 4 RAM buffers the same size as the 4 files being transferred.
- initializes the two serial ports to 19.2k, 8, N, 1 and enables the FIFOs and line status registers. Receiver FIFO trigger levels are set to 14.
- programs the following into the DMA controller:
 - starting address of the RAM buffers into the Memory Address registers
 - I/O addresses of the UART receive and transmit FIFOs into the I/O address registers
 - number of bytes in the files into the Terminal Count registers
 - receiver channels' Extended Mode registers are set for 8-bit transfers from memory to the programmed I/O addresses
 - transmit channels' Extended Mode registers are set for 8-bit transfers from the programmed I/O addresses to memory
- fills transmit data buffers with 00–FFh test data
- 8259 PIC is programmed to execute dma_int() upon receiving an IRQ3 interrupt
- Enables UART DMA request by writing xFh to DMA_EN
- waits for all file transfers to complete

The DMA channels programmed for the UART requests are: channel 0—RXRDY1; channel 1—RXRDY1; channel 6—TXRDY1; channel 7—TXRDY1. These numbers correspond to the arbitration vectors specified in the adapter's ADF.

Immediately after enabling the UART DMA requests, the adapter will generate transmit FIFO empty requests (TXRDY1 and TXRDY2), the controller will service the requests and data will begin transmitting from the UART. One or two other systems must also begin at this time to transmit

00–FFh test data to the two receivers. The size of these files must be the same as the Terminal Count programmed into the DMA channels servicing the receivers. The receivers will generate their first request after the first 14 bytes arrive. The CPU sits in a wait loop while the DMA controller continues to service the serial ports. The program stops after all four files have been transferred.

The dma_int() IRQ3 service routine is executed if a line status error is generated or a TC is generated by a file transfer completion. The routine first checks for line status errors in both channels. It then reads the 1-bit Interrupt Status Register (ISR) which will be set if a TC has occurred. The program then identifies which of the four file transfers completed by reading the DMA controller's status registers. They contain bit locations for all 8 channels which are set if a TC has been reached on that channel.

For any channel that has generated a TC, the DMA controller mask bit for that channel is set along with a flag signifying file transfer completion. If a channel servicing a receiver generated a TC, the received data is also verified by checking the data in the RAM buffer. Finally, RAM buffers are deallocated.

RXTXI.C

This driver is identical to RXTX.C except that the DMA channels servicing the UART transmitter FIFOs are programmed differently and TC interrupts for the transmitters are serviced differently. This is a sample driver for the old version of the PC16552C which cannot run slave-terminated bursts on the transmitter.

The DMA channels for the transmit FIFOs are programmed with a TC of 16 or less—not with the size of the entire file. This causes the controller to terminate the burst when the FIFO is full instead of waiting for TXRDY to go inactive which will be late as discussed in Design Considerations. During initialization and after every burst transfer to the transmit FIFOs, the TC is programmed for 16 bytes unless there are less than that left in the file. A software counter keeps track of the number of bytes transferred.

dma_int() is executed after every service of the FIFO because of the TC indication. Line Status interrupts and the receiver channels are treated the same as in RXTX.C. Transmitter channels are masked, have their TC registers reloaded as explained above and then unmasked. DMA_EN is written with a special mask variable (ch_complete) that remembers which DMA channels are no longer in operation so as not to inadvertently enable another channel.

EISA BUS DESIGN COMPARISON

From a DMA slave's point of view, the DMA system in EISA machines is essentially the same as in ISA machines. DMA requests from a slave device interface directly to the EISA bus DRQ signals. No local arbitration is necessary.

An EISA bus design utilizing the PC16552C DMA request signals would be much simpler than the Micro Channel design. The RXRDY and TXRDY DMA request signals would be connected directly to 4 different system DRQ signals, eliminating the need for the Local Arbiter, Fairness logic, request selection and lockout, and the generation of 4 arbitration vectors. However it would still be necessary to implement a DMA request enable register and Terminal Count handling logic.

The advantage of a DMA slave design for an EISA machine over an ISA machine is the increased DMA transfer rate. EISA specifies enhanced DMA modes which will transfer data at a substantially higher rate than the 4 MHz rate that is standard on ISA machines.

Adapter Description File Listing—@6E6D.adf

AdapterId 06E6Dh

AdapterName "NSC PC16552C Dual Async Adapter"

NumBytes 4

NamedItem

Prompt "Connector 1"

choice "SERIAL_1"	pos[0]=X011XXXXb	pos[1]=XX000XXXb	io 03f8h-03ffh	02f7h-02f7h	int 4
choice "SERIAL_2"	pos[0]=X001XXXXb	pos[1]=XX000XXXb	io 02f8h-02ffh	02f7h-02f7h	int 3
choice "SERIAL_3"	pos[0]=X100XXXXb	pos[1]=XX011XXXb	io 3220h-3227h	02f7h-02f7h	int 3
choice "SERIAL_4"	pos[0]=X101XXXXb	pos[1]=XX011XXXb	io 3228h-322fh	02f7h-02f7h	int 3
choice "SERIAL_5"	pos[0]=X100XXXXb	pos[1]=XX100XXXb	io 4220h-4227h	02f7h-02f7h	int 3
choice "SERIAL_6"	pos[0]=X101XXXXb	pos[1]=XX100XXXb	io 4228h-422fh	02f7h-02f7h	int 3
choice "SERIAL_7"	pos[0]=X100XXXXb	pos[1]=XX101XXXb	io 5220h-5227h	02f7h-02f7h	int 3
choice "SERIAL_8"	pos[0]=X101XXXXb	pos[1]=XX101XXXb	io 5228h-522fh	02f7h-02f7h	int 3

Help "This connector on the IBM Dual Async Adapter can be assigned to use Serial 1 though Serial 8. Use the F5= Previous and the F6=Next keys to change serial port assignments if you are in the 'Change configuration' window. Conflicting assignments are marked with an asterisk and must be changed to use the adapter."

NamedItem

Prompt "Connector 2"

choice "SERIAL_1"	pos[0]=XXXX011Xb	pos[1]=XXXX000b	io 03f8h-03ffh		int 4
choice "SERIAL_2"	pos[0]=XXXX001Xb	pos[1]=XXXX000b	io 02f8h-02ffh		int 3
choice "SERIAL_3"	pos[0]=XXXX100Xb	pos[1]=XXXX011b	io 3220h-3227h		int 3
choice "SERIAL_4"	pos[0]=XXXX101Xb	pos[1]=XXXX011b	io 3228h-322fh		int 3
choice "SERIAL_5"	pos[0]=XXXX100Xb	pos[1]=XXXX100b	io 4220h-4227h		int 3
choice "SERIAL_6"	pos[0]=XXXX101Xb	pos[1]=XXXX100b	io 4228h-422fh		int 3
choice "SERIAL_7"	pos[0]=XXXX100Xb	pos[1]=XXXX101b	io 5220h-5227h		int 3
choice "SERIAL_8"	pos[0]=XXXX101Xb	pos[1]=XXXX101b	io 5228h-5227h		int 3

Help "This connector on the IBM Dual Async Adapter can be assigned to use Serial 1 through Serial 8. Use the F5= Previous and the F6=Next keys to change serial port assignments if you are in the 'Change configuration' window. Conflicting assignments are marked with an asterisk and must be changed to use the adapter."

NamedItem

Prompt "Extended Cycle Mode"

choice "Synchronous Extended" pos[3]=XX1XXXXXb

Help "This sets the synchronous extended mode. It must always be set."

NamedItem

Prompt "Fairness On/Off"

choice "On" pos[0]=1XXXXXXXb choice "Off" pos[0]=0XXXXXXXb

Help "Bus Arbitration Fairness. This controls whether the adapter will release control of the bus when it has been using it exclusively. All four UART channels will use Fairness when it is On. Under normal circumstances, select <On>."

NamedItem

Prompt "DMA Arbitration Level for Channel 1 Receiver"

choice "Level 0"	pos[2]=XXXX0000b	arb 0
choice "Level 1"	pos[2]=XXXX0001b	arb 1
choice "Level 3"	pos[2]=XXXX0011b	arb 3
choice "Level 4"	pos[2]=XXXX0100b	arb 4
choice "Level 5"	pos[2]=XXXX0101b	arb 5
choice "Level 6"	pos[2]=XXXX0110b	arb 6

Help "This selects the arbitration level and DMA channel for Channel 1 Receiver."

NamedItem

Prompt "DMA Arbitration Level for Channel 1 Receiver"

choice "Level 0" pos[2]=0000XXXXb arb 0

choice "Level 1" pos[2]=0001XXXXb arb 1

choice "Level 3" pos[2]=0011XXXXb arb 3

choice "Level 4" pos[2]=0100XXXXb arb 4

choice "Level 5" pos[2]=0101XXXXb arb 5

choice "Level 6" pos[2]=0110XXXXb arb 6

Help "This selects the arbitration level and DMA channel for Channel 2 Receiver."

NamedItem

Prompt "DMA Arbitration Level for Channel 1 Transmitter"

choice "Level 0" pos[3]=XXXX0000b arb 0

choice "Level 1" pos[3]=XXXX0001b arb 1

choice "Level 3" pos[3]=XXXX0011b arb 3

choice "Level 4" pos[3]=XXXX0100b arb 4

choice "Level 5" pos[3]=XXXX0101b arb 5

choice "Level 6" pos[3]=XXXX0110b arb 6

Help "This selects the arbitration level and DMA channel for Channel 1 Transmitter."

PC16552C Adapter PAL/State Machine Equations

BUSARB: Local Arbiter State Machine

The following asynchronous state machine controls the Local Arbiter on the Adapter Card. The device used is a 20L8 PAL.

outputs: q3, q2, q1, q0, burst, preout, ack, enarb: pins 21, 20, 19, 18, 17, 16, 22, 15;

inputs: dreq, arbgnt, buswin, prein, chrst: pins 1, 2, 3, 4, 5;

States of Arbiter

idle = [1,1,1,1];

req = [1,1,1,0]; "req uchannel bus; preout (q0) active

arb = [1,0,1,0]; "vector enabled; preout, enarb active

lose = [1,0,0,0]; "lost arb battle; preout active

xfer1 = [0,0,1,0]; "intermediate state to xfer2

xfer2 = [0,0,1,1]; "xfering data on bus; burst ack active

xfer3 = [1,0,1,1]; "intermediate state to idle

Equations

!q0 = idle & !dreq & !lrbgnt & !chrst # "This is also PREEMPT

req & !dreq & !lrbgnt & !chrst #

req & !dreq & arbgnt & !chrst #

arb & arbgnt & !chrst #

arb & !lrbgnt & buswin & !chrst #

arb & !lrbgnt & !buswin & !chrst #

lose & !lrbgnt & !chrst #

lose & arbgnt & !chrst;

!q1 = arb & !lrbgnt & buswin & !chrst #

lose & !lrbgnt & !chrst;

!q2 = req & !dreq & arbgnt & !chrst #

arb & arbgnt & !chrst #

arb & !lrbgnt & buswin & !chrst #

arb & !lrbgnt & !buswin & !chrst #

lose & !lrbgnt & !chrst #

lose & arbgnt & !chrst #

xfer1 & !chrst #

xfer2 & !dreq & !lrbgnt & !chrst #

xfer2 & dreq & !lrbgnt & !chrst;

```
!q3 = arb & !arbgnt & !buswin & !chrst #
      xfer1 & !chrst # xfer2 & !dreq & !arbgnt & !chrst;
!enarb=arb#xfer1#xfer2;           "enables arb vector (ARB0-3) on bus
!ack=xfer 2;                       "acknowledge signal enable
burst=xfer2;                       "BURST on MCA Bus (TRI-STATE output)
enable preout=!q0;                 "PREEMPT on MCA Bus (TRI-STATE output)
burst=0;
preout=0;
```

ARBCON: Local Arbiter-Arbitration Bus Interface Logic

This logic drives and monitors the 4-bit Arbitration Bus during arbitration cycles. The device used is a 20L10 PAL.

Outputs: buswin, arb3, arb2, arb1, arb0, Q3, Q2, Q; pins 22, 21, 20, 19, 18, 17, 16, 15;

Inputs: sel3, sel2, sel1, sel0, enarb: pins 1, 2, 3, 4, 5;

Equations

arb3 = 0; arb2 = 0; arb1 = 0; arb0 = 0; "When enabled, these TRI-STATE outputs will be pulled low.

Q = (arb3 # !sel3);

Q2 = (arb3 # !sel3) & (arb2 # !sel2);

Q3 = (arb1 # !sel1);

!buswin = Q2 & Q3 & (arb0 # !sel0) and !enarb;

enable arb3 = !sel3 & !enarb;

enable arb2 = !sel2 & Q & !enarb;

enable arb1 = !sel1 & Q2 & !enarb;

enable arb0 = !sel0 & Q2 & Q3 & !enarb;

LOCKOUT: Device Request Lockout State Machine

This machine selects and prioritizes the four UART DMA requests and issues a single request to the Local Arbiter. Once a particular request is selected, all others are locked out. The device used is 16L8D PAL.

Outputs dreq, s1, s0, q0, q1, q2, q3: pins 12, 13, 14, 15, 16, 17, 18;

Inputs: rxrdy1, rxrdy2, txrdy1, txrdy2, delay, chrst: pins 1, 2, 3, 4, 5, 6;

States of lockout machine

idle = [1,1,1,1,]; rx1 = [1,1,1,0]; rx2 = [1,1,0,1]; tx1 = [1,0,1,1,]; tx2 = [0,1,1,1];

Equations

!q0 = idle & rxrdy1 & !delay & !chrst # !q0 & rxrdy1 & !chrst;

!q1 = idle & !rxrdy1 & rxrdy2 & !delay & !chrst # q0 & !q1 & rxrdy2 & !chrst;

!q2 = idle & !rxrdy1 & !rxrdy2 & txrdy1 & !delay & !chrst # q0 & q1 & !q2 & txrdy1 & !chrst;

!q3 = idle & !rxrdy1 & !rxrdy2 & !txrdy1 & txrdy2 & !delay & !chrst # q0 & q1 & q2 & !q3 & txrdy2 & !chrst;

rx1win = q0; rx2win = q1; tx1win = q2; tx2win = q3;

s0 = q0 & (!q1 # q2);

s1 = q0 & q1;

dreq = rx1win & rx2win & tx1win & tx2win;

FAIR1/FAIR2: Local Arbiter Fairness State Machines

These equations describe two independent state machines which gate the RXRDY1 and RXRDY2 signals in such a way that they obey the Fairness algorithm. Both machines are contained in a 16L8 PAL. The equations for the transmitter signal state machines (contained in FAIR2 PAL) are identical to these equations except that the receiver signals are exchanged for corresponding transmitter signals and vice versa.

Outputs: rx1q1, rx1q0, rx2q1, rx2q0, rx1fair, rx2fair: pins 13, 14, 15, 16, 17, 18;

Inputs: rx1, rx2, tx1, tx2, PREEMPT, fair chrst: pins 1, 2, 3, 4, 5, 6, 7;

States:

rx1__st = [rx1q1, rx1q0]; rx2__st = [rx2q1, rx2q0];

rx1_idle = rx1__st == [1,1];

rx1_xfr = rx1__st == [1,0];

rx1_wait = rx1__st == [0,0];

rx1_temp = rx1__st == [0,1];

rx2_idle = rx2__st == [1,1];

rx2_xfr = rx2__st == [1,0];

rx2_wait = rx2__st == [0,0];

rx2_temp = rx2__st == [0,1];

Equations

!rx1q0 = rx1_idle & rx1 & !chrst #
rx1_xfr & rx1 & !chrst #
rx1_xfr & !rx1 & fair & !chrst # rx1_wait & fair & !(rx2 & !tx1 & !tx2 & PREEMPT) & !chrst;

!rx1q1 = rx1_xfr & !rx1 & fair & !chrst #
rx1_wait & !(rx2 & !tx1 & !tx2 & PREEMPT) & !chrst #
rx1_wait & rx2 & !tx1 & !tx2 & PREEMPT & !chrst;

!rx2q0 = rx2_dle & rx2 & !chrst #
rx2_xfr & rx2 & !chrst #
rx2_xfr & !rx2 & fair & !chrst #
rx2_wait & fair & !(rx1 & !tx1 & !tx2 & PREEMPT) & !chrst;

!rx2q1 = rx2_xfr & !rx2 & fair & !chrst #
rx2_wait & !(rx1 & !tx1 & !tx2 & PREEMPT) & !chrst #
rx2_wait & rx1 & !tx1 & !tx2 & PREEMPT & !chrst;

rx1fair = !rx1q1;

rx2fair = !rx2q1;

Interrupt Logic

This logic provides the interface between the UART and TC interrupts and the IRQ3 and IRQ4 signals on the Micro Channel. It also provides the Adapter ID bytes in response to ID byte reads. The device used is a 16L8 PAL.

Outputs IRQ3__EN, IRQ4__EN, IRQ3, IRQ4, bit 7, bit 4 bit 1, bit 0: pins 15, 16, 17, 18, 19, 12, 14, 13;

Inputs: intr1, intr2, P102B2, P102B5, CDEN, RD100, RD101, dma__int, RD__BOTH: pins 1, 2, 3, 4, 5, 6, 7, 8, 9;

Equations

enable IRQ3 = intr1 & !P102B5 & CDEN #
intr2 & !P102B2 & CDEN #
dma__int & CDEN;

enable IRQ4 = intr1 & P102B5 & CDEN #
intr2 & P102B2 & CDEN;

IRQ3 = 0; IRQ4 = 0

enable bit 7 = RD__BOTH;

enable bit 4 = RD__BOTH;

enable bit 1 = !RD100;

enable bit 0 = !RD101;

bit 7 = 0; bit 4 = 0; bit 1 = 0; bit 0 = 0;

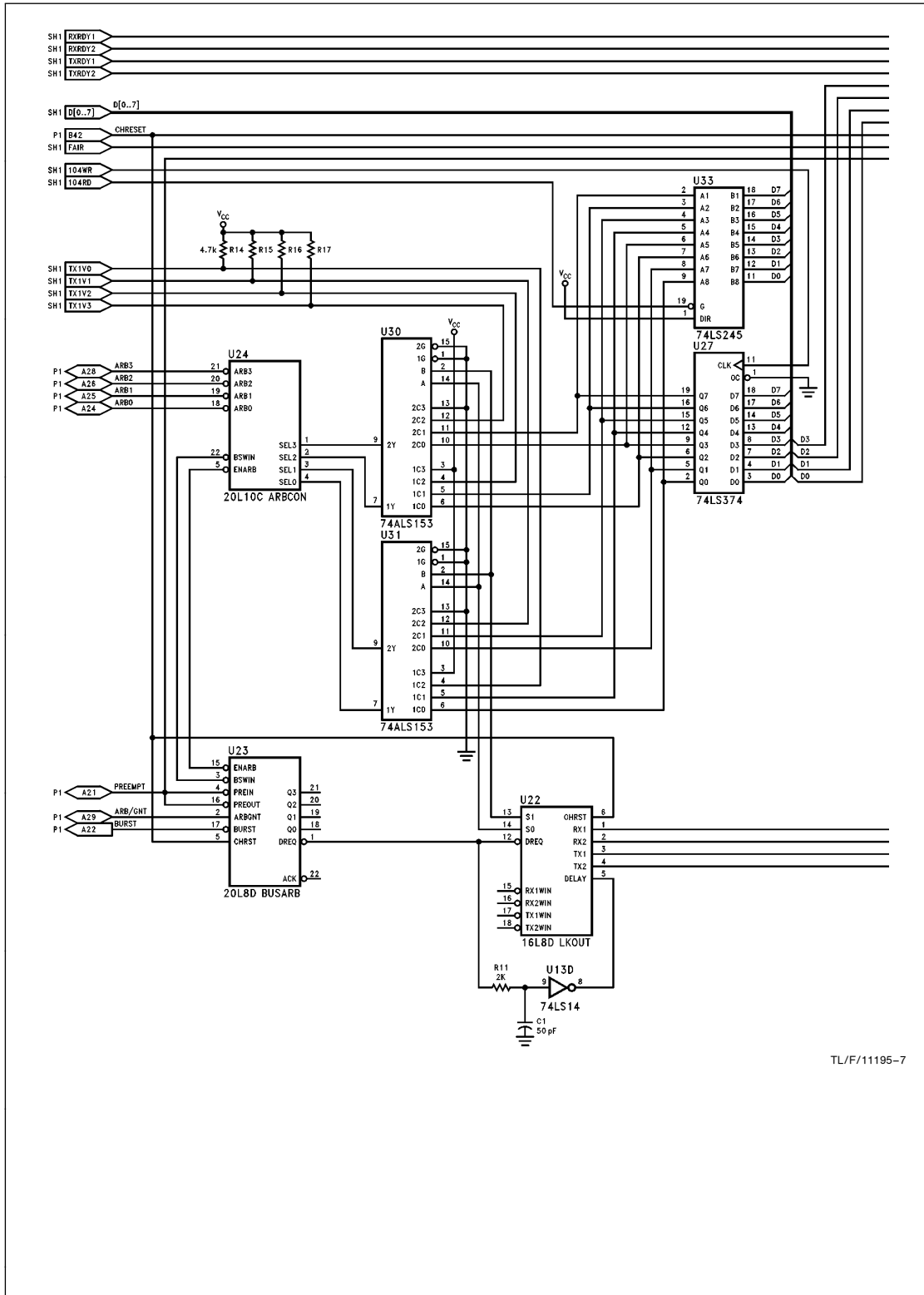

TL/F/11195-7

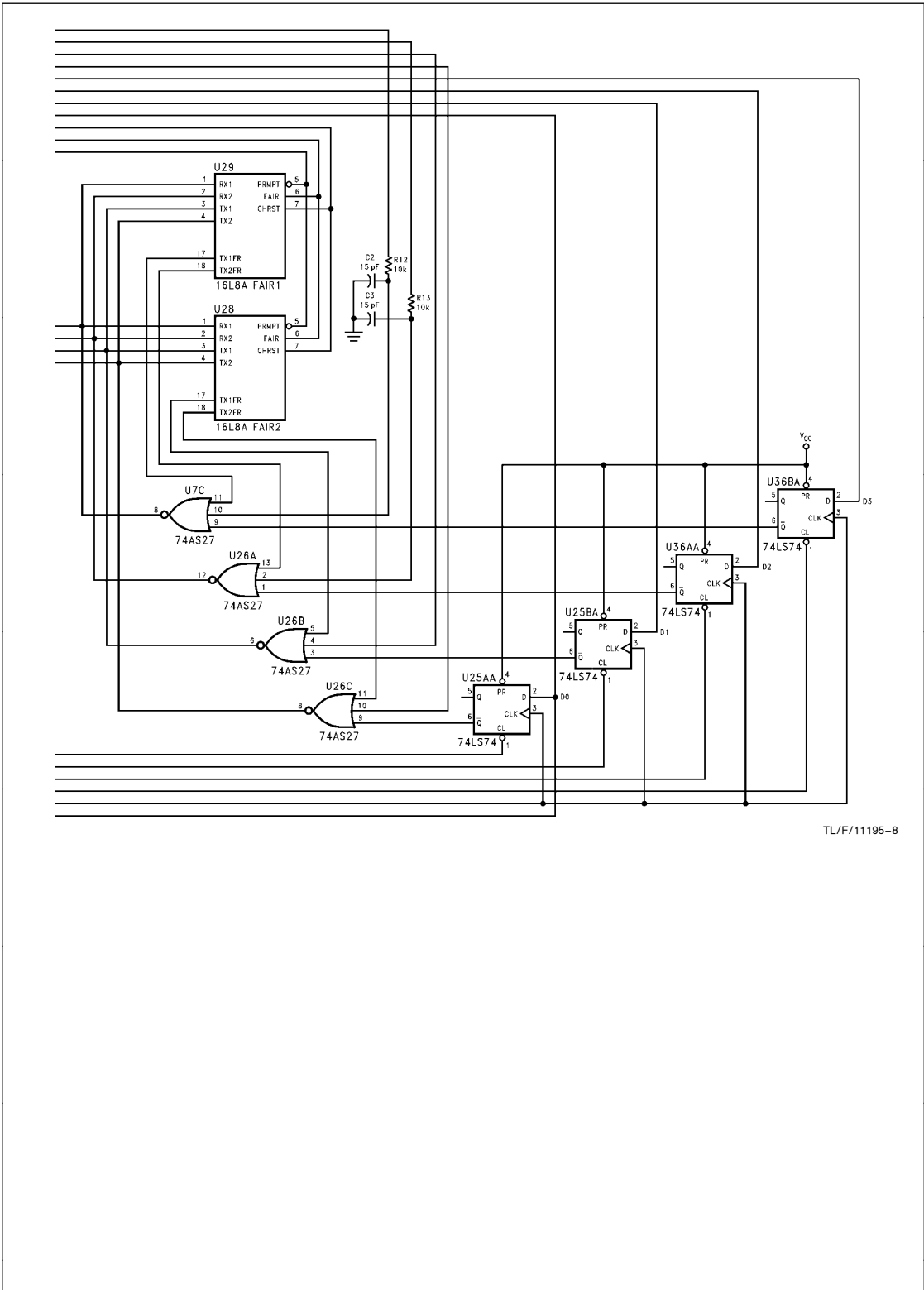

TL/F/11195-8

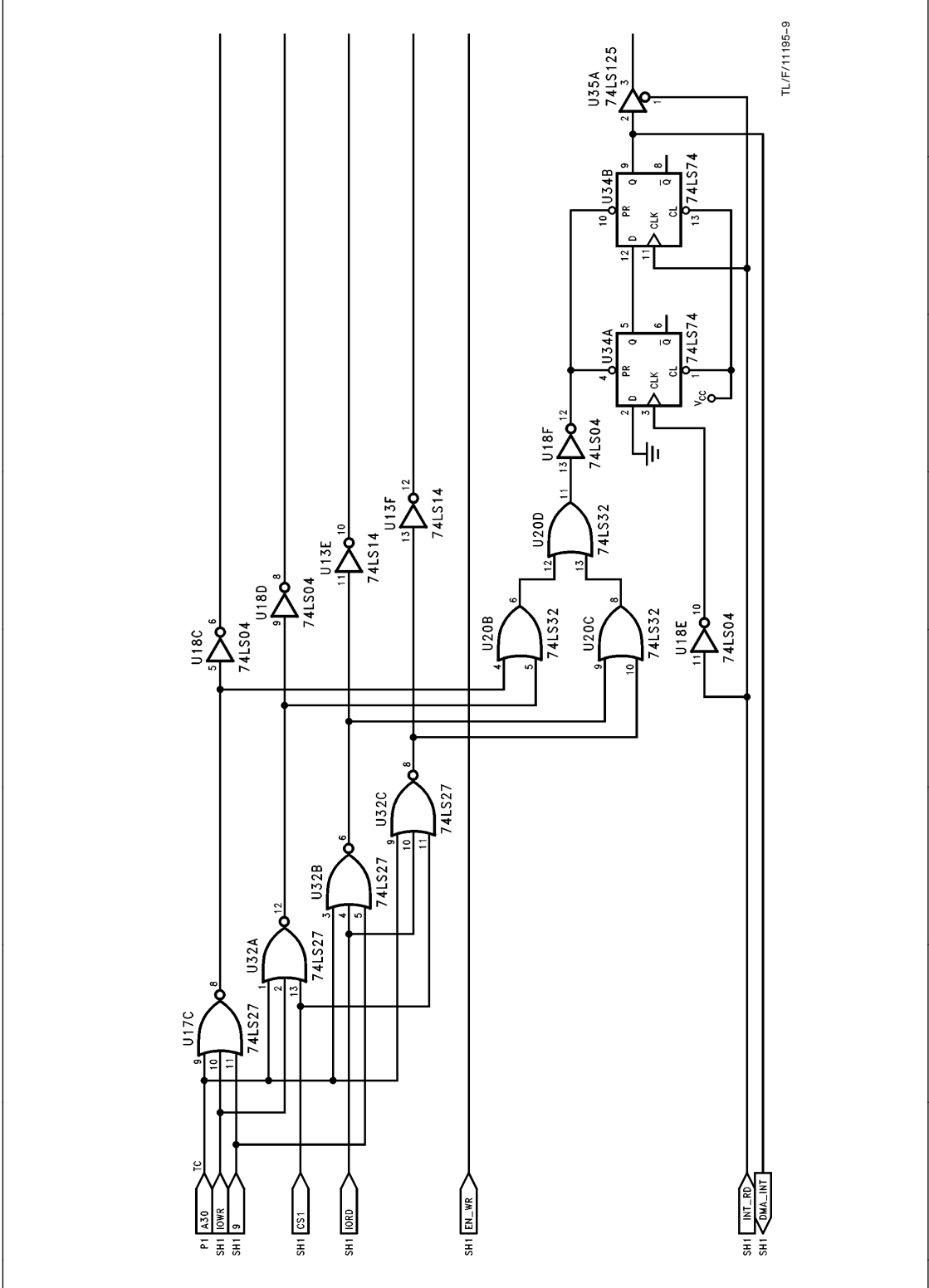

TL/F/11195-9

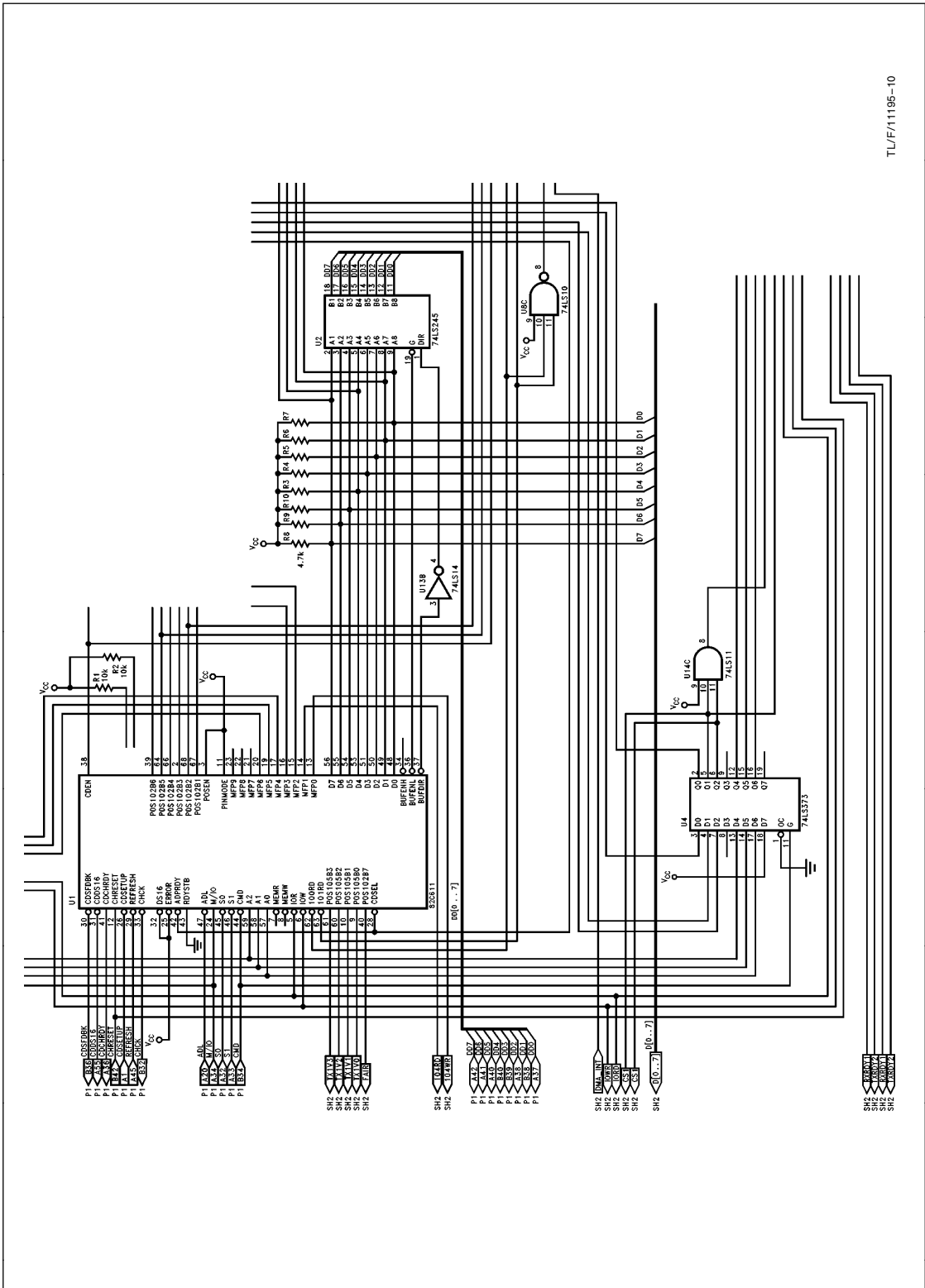

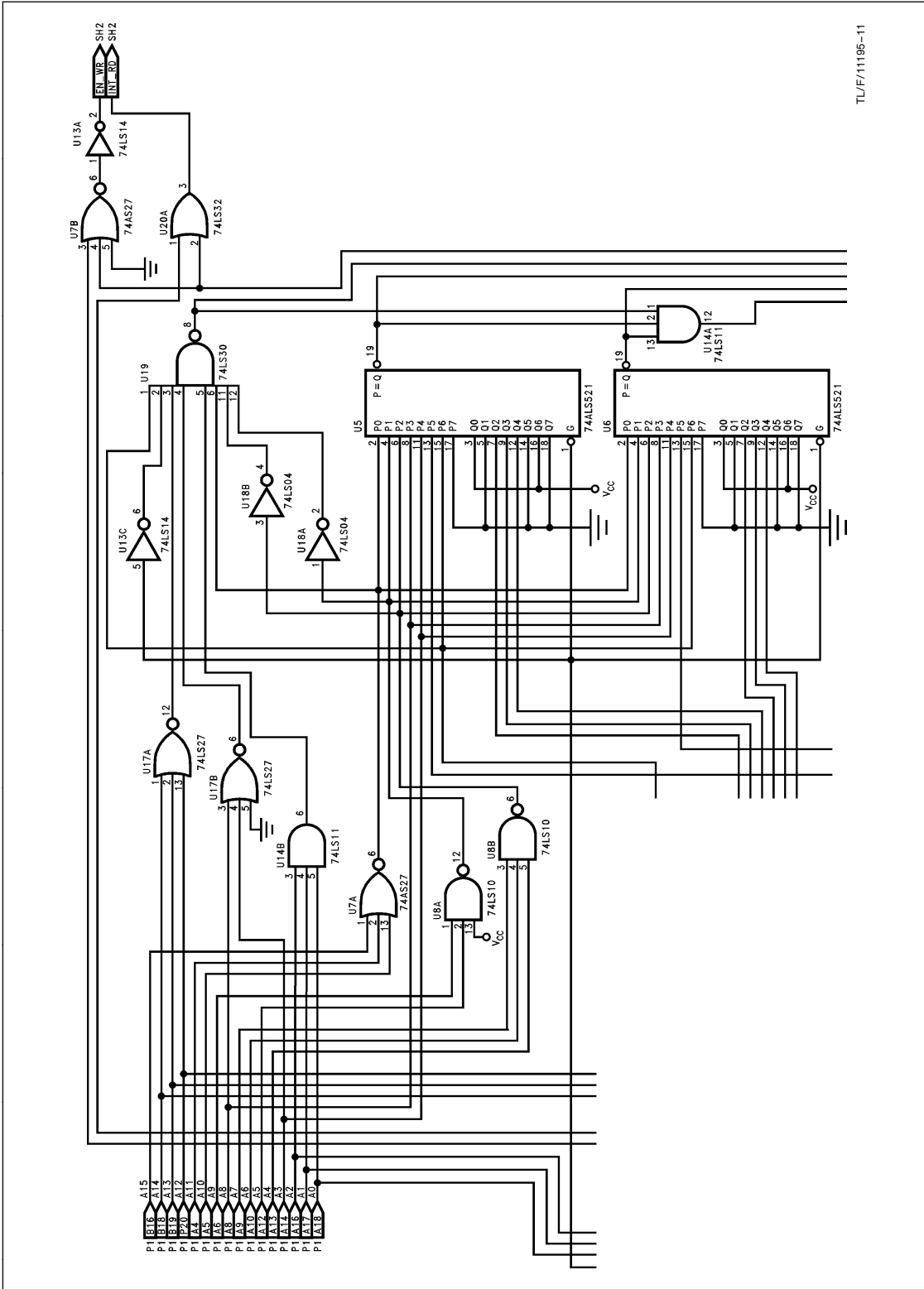

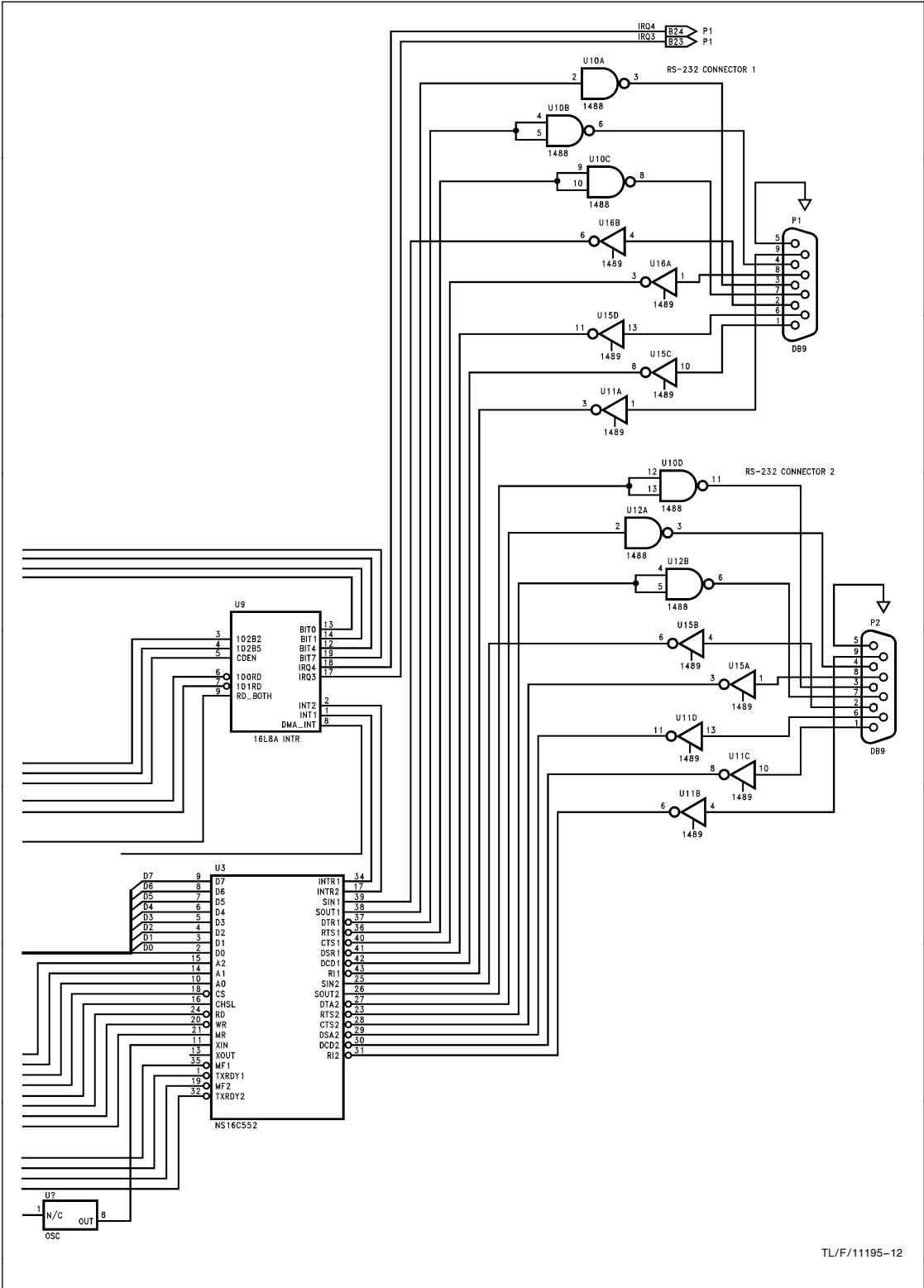

LIFE SUPPORT POLICY

NATIONAL'S PRODUCTS ARE NOT AUTHORIZED FOR USE AS CRITICAL COMPONENTS IN LIFE SUPPORT DEVICES OR SYSTEMS WITHOUT THE EXPRESS WRITTEN APPROVAL OF THE PRESIDENT OF NATIONAL SEMICONDUCTOR CORPORATION. As used herein:

1. Life support devices or systems are devices or systems which, (a) are intended for surgical implant into the body, or (b) support or sustain life, and whose failure to perform, when properly used in accordance with instructions for use provided in the labeling, can be reasonably expected to result in a significant injury to the user.
2. A critical component is any component of a life support device or system whose failure to perform can be reasonably expected to cause the failure of the life support device or system, or to affect its safety or effectiveness.



National Semiconductor Corporation
 2900 Semiconductor Drive
 P.O. Box 58090
 Santa Clara, CA 95052-8090
 Tel: 1(800) 272-9959
 TWX: (910) 339-9240

National Semiconductor GmbH
 Livny-Gargan-Str. 10
 D-82256 Fürstenfeldbruck
 Germany
 Tel: (81-41) 35-0
 Telex: 527849
 Fax: (81-41) 35-1

National Semiconductor Japan Ltd.
 Sumitomo Chemical
 Engineering Center
 Bldg. 7F
 1-7-1, Nakase, Mihama-Ku
 Chiba-City,
 Ciba Prefecture 261
 Tel: (043) 299-2300
 Fax: (043) 299-2500

National Semiconductor Hong Kong Ltd.
 13th Floor, Straight Block,
 Ocean Centre, 5 Canton Rd.
 Tsimshatsui, Kowloon
 Hong Kong
 Tel: (852) 2737-1600
 Fax: (852) 2736-9960

National Semicondutores Do Brazil Ltda.
 Rue Deputado Lacorda Franco
 120-3A
 Sao Paulo-SP
 Brazil 05418-000
 Tel: (55-11) 212-5066
 Telex: 391-1131931 NSBR BR
 Fax: (55-11) 212-1181

National Semiconductor (Australia) Pty, Ltd.
 Building 16
 Business Park Drive
 Monash Business Park
 Nottingham, Melbourne
 Victoria 3168 Australia
 Tel: (3) 558-9999
 Fax: (3) 558-9998

National does not assume any responsibility for use of any circuitry described, no circuit patent licenses are implied and National reserves the right at any time without notice to change said circuitry and specifications.