



Low Cost 16-Pin Frequency Generator

General Description

The **AV9154-16** is a low-cost frequency generator designed for general purpose PC and disk drive applications. Its CPU clocks provide all necessary frequencies for 286, 386 and 486 systems, including support for the latest speeds of processors. The standard devices use a 14.318 MHz crystal to generate the CPU and peripheral clocks for integrated desktop and notebook motherboards.

The CPU clock offers the unique feature of smooth, glitch-free transitions from one frequency to the next, making this ideal device to use whenever slowing the CPU speed. The **AV9154-16** makes a gradual transition between frequencies, so that it obeys the Intel cycle-to-cycle timing specification for 486 systems.

ICS has been shipping Motherboard Frequency Generators since April 1990, and is the leader in the area of multiple output clocks on a single chip. The **AV9154-16** uses the same technology as ICS's highly successful AV9107 and AV9155 products. ICS offers a broad family of frequency generators for motherboards, graphics and other applications, including cost effective versions with only one or two output clocks. Consult ICS for all of your clock generation needs.

Features

- Compatible with 286, 386 and 486 CPUs
- Generates 4 output clocks for CPU plus peripherals
- Up to 100 MHz
- All loop filter components internal
- Skew-controlled 2X and 1X CPU clocks
- 3.3V and 5V versions
- 16-pin PDIP or 150-mil wide SOIC
- Power-down options for CPU and REF included

Applications

Computer Motherboards: The **AV9154-16** replaces crystals and oscillators, saving board space, component cost, part count and inventory costs. It produces a switchable CPU clock, and three fixed clocks to drive floppy disk, bus, and/or keyboard devices. The small package and 3.3V operation is perfect for handheld computers.

Block Diagram

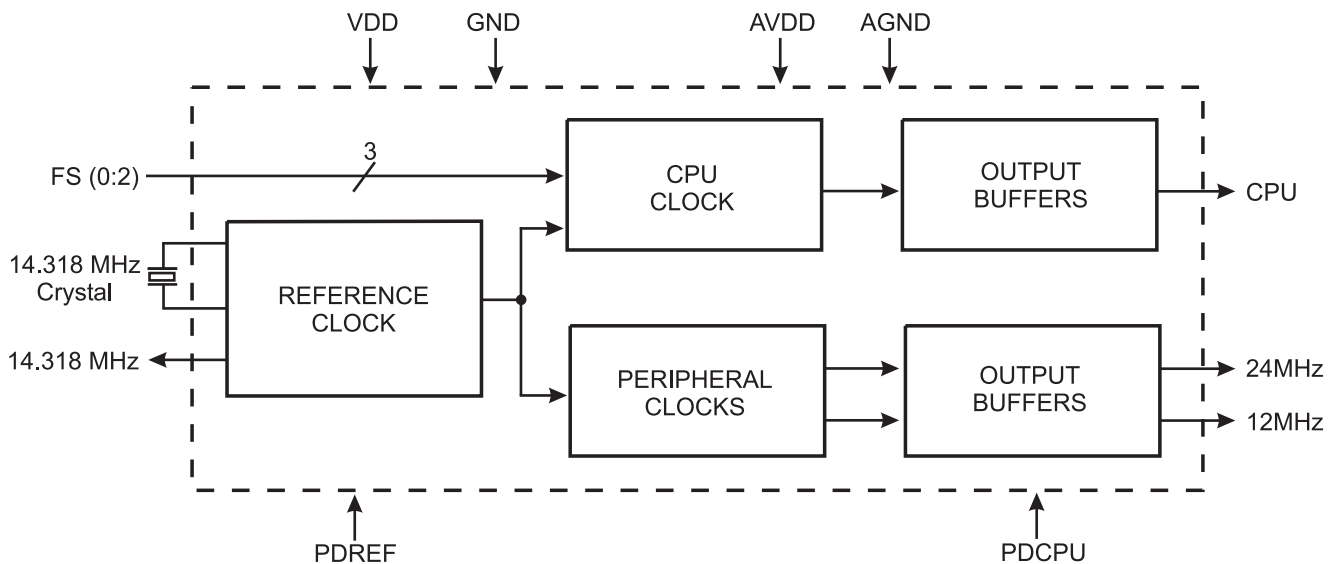



AV9154-16

Pin Configuration

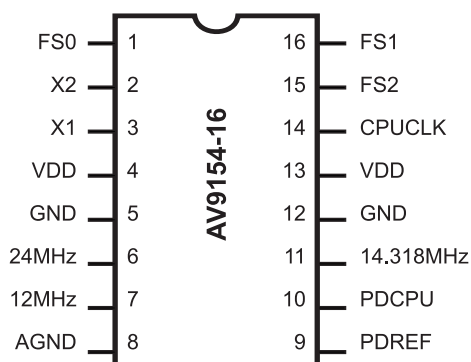

16-Pin DIP or SOIC

Functionality (in MHz.)

FS2	FS1	FS0	CPUCLK
0	0	0	16.11
0	0	1	20.05
0	1	0	25.06
0	1	1	33.41
1	0	0	40.09
1	0	1	50.11
1	1	0	66.48*
1	1	1	80.18*

* These selections will only operate at 5V.

Pin Descriptions

PIN NUMBER	PIN NAME	TYPE	DESCRIPTION
1	FS0	Input	Frequency select 0 for CPUCLK.
2	X2	Output	Crystal out. This pin includes XTAL load capacitance.
3	X1	Input	Crystal in. This input includes internal XTAL load capacitance and feedback bias for the crystal (nominally 14.31818 MHz).
4	VDD	Power	Digital power.
5	GND	Power	Digital ground.
6	24 MHz	Output	24 MHz clock output.*
7	12 MHz	Output	12 MHz clock output.*
8	AGND	Power	Analog ground.
9	PDREF	Input	Power-down reference clock (14.318 MHz) (Active high).
10	PDCPU	Input	Power-down CPU clock (Active high).
11	14.318 MHz	Output	14.318 MHz reference clock output.*
12	GND	Power	Digital ground.
13	VDD	Power	Digital power.
14	CPUCLK	Output	CPU clock output determined by status of FS0 - FS2.
15	FS2	Input	Frequency select 2 for CPUCLK.
16	FS1	Input	Frequency select 1 for CPUCLK.

Note: No internal pull-ups on any inputs. * With input crystal of 14.318 MHz.



Absolute Maximum Ratings

- VDD referenced to GND 7V
- Operating temperature under bias 0°C to +70°C
- Storage temperature -40°C to +150°C
- Voltage on I/O pins referenced to GND. GND -0.5V to VDD +0.5V
- Power dissipation 0.5 Watts

Stresses above those listed under Absolute Maximum Ratings may cause permanent damage to the device. This is a stress rating only and functional operation of the device at these or any other conditions above those indicated in the operational sections of the specifications is not implied. Exposure to absolute maximum rating conditions for extended periods may affect product reliability.

Electrical Characteristics at 5V

V_{DD} = 4.5 to 5.5V, T_A = 0°C to 70°C unless otherwise stated

DC Characteristics						
PARAMETER	SYMBOL	TEST CONDITIONS	MIN	TYP	MAX	UNITS
Input Low Voltage	V _{IL}	V _{DD} =5V			0.8	V
Input High Voltage	V _{IH}	V _{DD} =5V	2.0			V
Input Low Current	I _{IL}	V _{IN} =0V			-5	μA
Input High Current	I _{IH}	V _{IN} =V _{DD}			5	μA
Output Low Voltage ¹	V _{OL}	I _{OL} =4mA			0.4	V
Output High Voltage ¹	V _{OH}	I _{OH} =-1mA, V _{DD} =5.0V	V _{DD} -0.4V			V
Output High Voltage ¹	V _{OH}	I _{OH} =-4mA, V _{DD} =5.0V	V _{DD} -0.8V			V
Output High Voltage ¹	V _{OH}	I _{OH} =-8mA	2.4			V
Supply Current	I _{DD}	No load ²		25	40	mA
Output Frequency Change over Supply and Temperature ¹	F _D	With respect to typical frequency		0.002	0.01	%
Short Circuit Current ¹	I _{SC}	Each output clock	25	40		mA
Input Capacitance ¹	C _i	Except X1, X2			10	pF
Load Capacitance ¹	C _L	Pins X1, X2		20		pF
Supply Current, Power-Down ¹	I _{CDSTBY}	No load		30		mA
AC Characteristics						
Input Clock Rise Time ¹	t _{ICr}				20	ns
Input Clock Fall Time ¹	t _{ICf}				20	ns
Output Rise time ¹	t _r	15pF load, 0.8 to 2.0V	-	1	2	ns
Rise time ¹	t _r	15pF load, 20% to 80% V _{DD}	-	2	4	ns
Output Fall time ¹	t _f	15pF load, 2.0 to 0.8V	-	1	2	ns
Fall time ¹	t _f	15pF load, 80% to 20% V _{DD}	-	2	4	ns
Duty cycle ¹	d _t	15pF load @ 1.4V	40/60	48/52	60/40	%
Duty cycle, reference clocks ¹	d _t	15pF load @ 1.4V	40/60	43/57	60/40	%
Jitter, one sigma ¹	f _{j1s}	As compared with clock period		0.8	2.5	%
Jitter, absolute ¹	t _{j1s}			2	5	%
Jitter, absolute ¹	t _{j1s}	16-80 MHz clocks			700	ps
Input Frequency ¹	f _i			14.318		MHz
Frequency Transition time ¹	t _{ft}	From 16 to 80 MHz		12	20	ms

Notes: 1. Parameter is guaranteed by design and characterization. Not 100% tested in production.
 2. All clocks on AV9154-16 running at highest possible frequencies. Power supply current can change substantially with different mask configurations. Consult ICS.



AV9154-16

Electrical Characteristics at 3.3V

$V_{DD} = +2.7$ to $+3.7V$, $T_A = 0^\circ C$ to $70^\circ C$ unless otherwise stated

DC Characteristics						
PARAMETER	SYMBOL	TEST CONDITIONS	MIN	TYP	MAX	UNITS
Input Low Voltage	V_{IL}				$0.15V_{DD}$	V
Input High Voltage	V_{IH}		$0.7V_{DD}$	-	-	V
Input Low Current	I_{IL}	$V_{IN} = 0V$	-5	-	-5	μA
Input High Current	I_{IH}	$V_{IN} = V_{DD}$	-5	-	5	μA
Output Low Voltage ¹	V_{OL}	$I_{OL} = 8mA$	-	-	0.1	V
Output High Voltage ¹	V_{OH}	$I_{OH} = -4mA$	$V_{DD} - 1V$	-	-	V
Supply Current	I_{DD}	Note 2	-	25		mA
Output Frequency Change over Supply and Temperature ¹	F_d	With respect to typical frequency	-	0.002	0.01	%
Input Capacitance ¹	C_i	Except X1, X2			10	pF
Load Capacitance ¹	C_L	Pins X1, X2		20		pF
Supply Current, Standby	I_{DDSTBY}	When powered-down		15		μA
Short Circuit Current ¹	I_{SC}			30		mA
AC Characteristics						
Enable pulse width ¹	t_w		20	-	-	ns
Set-up time data to enable ¹	t_{su}		20	-	-	ns
Input Clock Rise time ¹	$ICLK_r$		-	-	20	ns
Input Clock Fall time ¹	$ICLK_f$		-	-	20	ns
Hold time data to enable ¹	t_{hd}		10	-	-	ns
Rise time ¹	t_r	15pF load, 20% to 80% V_{DD}	-	-	4	ns
Fall time ¹	t_f	15pF load, 80% to 20% V_{DD}	-	-	4	ns
Duty cycle ¹	d_t	15pF load, @ 50% V_{DD}	40	48/52	60	%
Jitter, 1 sigma ¹	T_{jis}	All frequencies		± 0.5	± 2	%
Jitter, absolute ¹	T_{jabs}	All frequencies		± 3	± 5	%
Frequency Transition time ¹	t_{ft}	From 16 to 50 MHz			15	ms
Power-up time ¹	t_{pu}	From off to 50 MHz		15		ms
Output Frequency ¹	f_o		2		50	MHz
Input Frequency ¹	f_i		2	14.318	32	MHz

Notes:

1. Parameter is guaranteed by design and characterization. Not 100% tested in production.
2. AV9154 with no load, with 14.318 MHz crystal input, and CLK1 running at 40 MHz. Power supply current varies with frequency. Consult ICS for actual current at different frequencies.

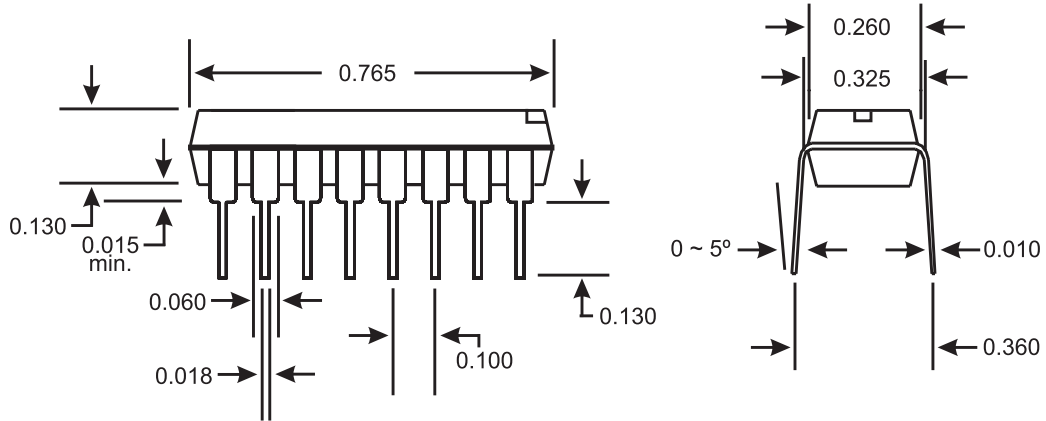

16-Pin PDIP Package

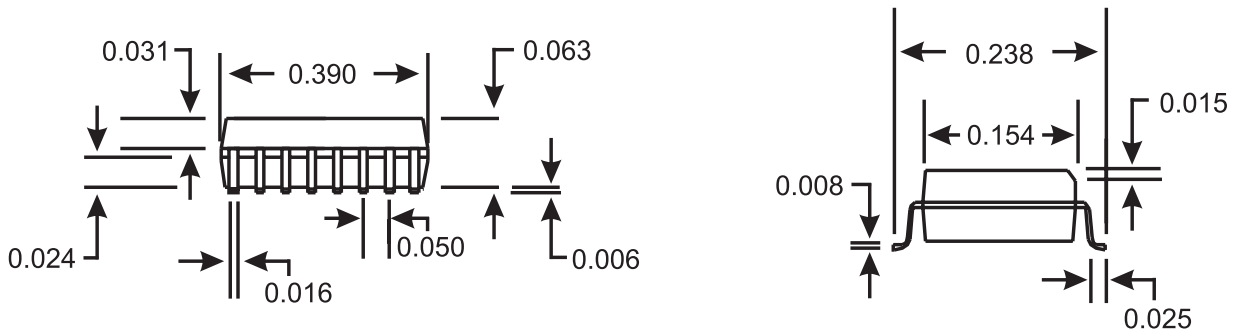

16-Pin SOIC Package

Ordering Information

AV9154-16CN16 or AV9154-116CS16

Example:

ICS XXXX-PPP M X#W

