

CPU Thermal Management



Advanced
Micro
Devices

Application Note

This application note describes CPU thermal management practices using a heat sink/fan combination. The heat sink/fan assembly helps to guard against processor overheating in systems where the airflow may be restricted by the addition of add-in cards or modules that can block airflow necessary for proper CPU cooling.

OVERVIEW

Heat is generated by all semiconductors while operating. Most microprocessors to date have been able to dissipate the heat directly to the ambient air without heat sinks or fans. With faster processors that dissipate more heat than the slower processors, it is no longer possible to ignore thermal management. The objective is to ensure the generated heat is dissipated into the ambient air while a safe operating temperature is maintained.

There are several methods for keeping the processor cool. All of these methods include a combination of heat sink and airflow. In general, the trade-off is heat sink versus airflow. A smaller and less costly heat sink requires more airflow. Analogously, larger heat sinks require less airflow to maintain a safe case temperature.

There are several choices of motherboards and computer cases that manufacturers can use in their assembly. After receiving the system, the end customer can populate the system with a myriad of add-on cards and peripherals; hence, it is extremely difficult to guarantee that the processor will be adequately cooled in all the different combinations of systems.

AMD has researched several products that aid in thermal management design. The product that effectively provides thermal management at a reasonable cost is the heat sink and fan combination. This product consists of a small fan mounted on a heat sink. The fan is powered by the standard power supply and connects via a cable. The heat sink is clipped on or glued to the microprocessor. The heat sink adds between $11/16"$ to $3/4"$ of height to the processor. The space above the fan and to the sides of the processor should be cleared to allow for proper airflow. A typical heat sink and fan assembly is shown in Figure 1.

AMD has tested various fan/heat sink devices and found the Thermalloy 2321B-TCM cooling module to provide reliable operation.

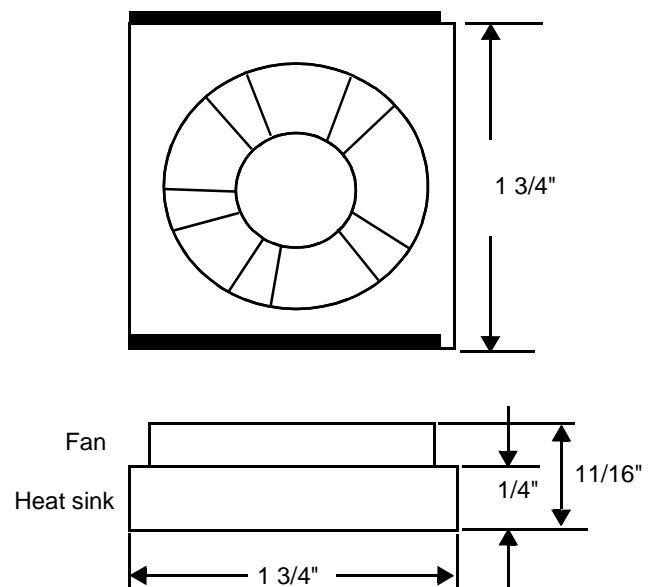

Figure 1. Heat Sink and Fan Assembly

HEAT SINKS AVAILABLE FOR Am486 AND Am5x86 CPUs

Thermalloy's Heat Sinks

Omnidirectional

Models: 2321B, 2332B, 2333B, 2342B

- 20% greater performance than extruded equivalents
- Heat Sinks may be bonded to the PGA with epoxy or with the PGA E-Z Mount frame (p/n 8317) and spring (p/n PF17)

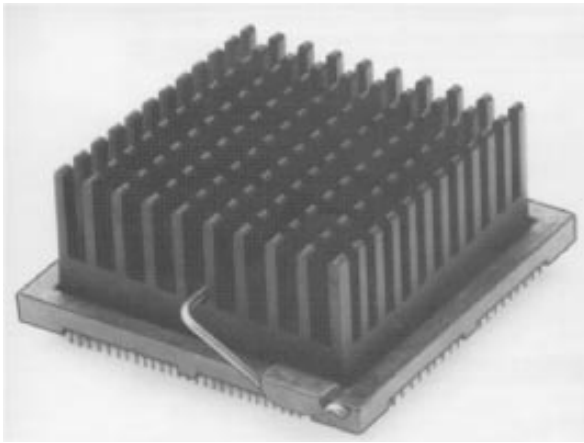

Figure 2. Omnidirectional Heat Sink

Thermalloy Cooling Modules (TCM)

Models: 2321B-TCM, 2333B-TCM

(Heat sink with fan attached)

- High performance relative to its low cost
- Fans available in 5 or 12 volts, 12 V recommended
- TCM assembly may be attached to PGA with Thermalloy's innovative PGA E-Z Mount frame and spring or epoxy.
- May be used in conjunction with PGA sockets, such as AMP 382624-1 and -2

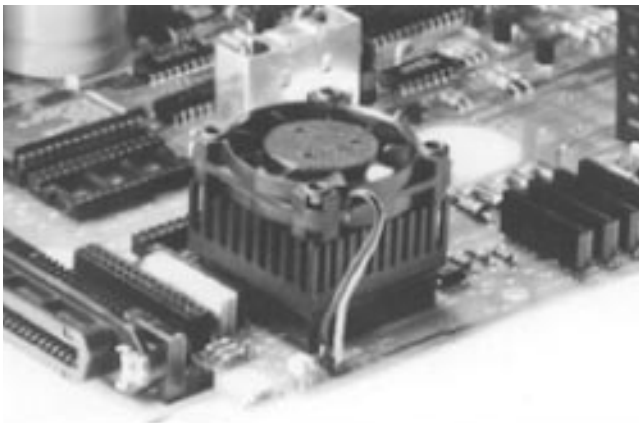

Figure 3. Thermalloy Cooling Module

Notes:

1. *Thermal paste is recommended in order to provide the best heat transfer.*
2. *When applying thermal paste, it should be applied in a thin, smooth even layer across the entire CPU package.*
3. *In **no** circumstance should an air gap exist between the CPU package and the heatsink. If a gap exists, the heatsink will provide little or not heat dissipation and therefore is useless.*

Other Available Heat Sinks

AMP Low Insertion Force PGA Sockets

Models: SCA17-1, SCA17-2

(Heat sink with tabs for spring clips)

- Spring clip (SCA17-x) attaches a Thermalloy pin fin heat sink (23xx series) to PGA in an AMP LIF PGA socket
- Clip easily snaps over the edges of the PGA socket and requires no special tools

AAVID's Heat Sinks

SINK-to-SOCKET Clip Heat Sinks

Models: 3333, 3334, 3335, 3336, 3337

(A clip that attaches the heat sink to an AMP Socket with the CPU in between)

- Removable heat sink and clip with built-in quick release/load latch

SINK-to-PROCESSOR Clip Heat Sinks

Models: 3600, 3331, 3601, 3602, 3603, 3329

(A clip that attaches the heat sink directly to the CPU)

- No keep-clear areas required
- Functions on socket or direct mount CPUs

PGA KLIPS Heat Sinks

(Uses PGA Klips for easy installation)

Bidirectional

Models: 3300, 3301, 3302, 340011

- Low cost heat sink
- Ideal for directional and high airflow patterns

Omnidirectional

Models: 3305, 3306, 3307, 340021

- Utilizes airflow from any direction
- Ideal for impingement airflow patterns

Fan-Sink Heat Sinks

Model 351055

(Heat sink that uses a fan)

- Low profile design
- Shrouded design maximizes cooling capacity

For Further Information Contact:

AAVID Engineering, Inc. U.S.A.: (603) 528-3400

Thermalloy, Inc.

U.S.A.: (214) 243-4321

U.K.: 0793537861

Hong Kong: 852-4647312

APPENDIX—Background Information

Thermal Resistance

Thermal characteristics of integrated circuits (IC) have long been a major concern for both electronic product manufacturers and designers. This is because an increase in junction temperature can have an adverse effect on the long term performance and operating life of an IC. With the 486 CPU, for example, squeezing 1.2 million transistors on board and running at faster speeds, more heat is generated which can not be easily vented out of the computer with the usual fans. Unvented, the heat builds up and destroys the transistors. Heat sinks are finding their way into 486 systems but they may not be good enough for future generations of CPUs.

The maximum case temperature of some Am486 CPUs is specified to be 65°C. The cooling module must dissipate the heat into the ambient air, which must be below 65°C. How much lower the ambient temperature must be is given by the thermal resistance times the power. Therefore, to calculate the maximum ambient temperature that the processor with cooling module can operate, the following formula is used:

$$T_{\text{Max - Ambient}} = 65 - (P_{\text{Max}} \cdot \theta_{\text{CA}})$$

The maximum power consumption (P_{Max}) of the Am486 processor is given as:

$$P_{\text{Max}} = 5.35 \text{ [V]} \cdot 1200 \text{ [mA]} = 6.3 \text{ Watts}$$

With unit 1 using the thermal grease, the maximum ambient temperature for safe operation will be:

$$T_{\text{Max - Ambient}} = 65 - (6.3 \cdot 3.3) = 44.21^\circ\text{C}$$

For comparison, by using the Thermalloy 2321B-TCM, the maximum ambient temperature is:

$$T_{\text{Max - Ambient}} = 65 - (6.3 \cdot 1.4) = 56.18^\circ\text{C}$$

When a transistor is turned on, power is dissipated equal to the product of the voltage across the collector junction and the current through it. As a result, the collector junction's temperature begins to rise. Eventually, a steady state is reached when the transistor dissipates the same energy supplied to it. This energy is in the form of heat and is given off through the case to the surrounding environment. The temperature depends upon the power level and the thermal resistance of the device package. Thermal resistance is the ability of the package to conduct heat away from the CPU and into the surrounding environment. A low thermal resistance value means that for a given amount of power, the integrated circuit junction will operate at a lower temperature, thereby providing a longer life time.

Several variables affect junction temperature. Some are controlled by the IC vendor, while others are controlled by the user and the environment in which the device is

used. With the trend toward higher density circuits, increasing circuit complexity and increasing number of pin outs, total power dissipation is increasing. Hence, management of thermal characteristics remains a valid concern.

Thermal resistance (θ_{jc}) is expressed as the rise in the collector junction temperature (T_{j}) above the case temperature (T_{c}) per unit of power dissipated (P_{d}) in the device.

$$(1) \quad \theta_{\text{jc}} = (T_{\text{j}} - T_{\text{c}}) / (P_{\text{d}})$$

Where θ_{jc} is expressed in $^\circ\text{C}/\text{W}$.

Thermal resistance can also be calculated between junction temperature and ambient temperature (T_{a}).

$$(1a) \quad \theta_{\text{ja}} = (T_{\text{j}} - T_{\text{a}}) / (P_{\text{d}})$$

Figure 4 illustrates the path of heat flow through a device with and without a heat sink, and Figure 5 shows a schematic representation of the thermal resistance paths between the junction and ambient temperatures.

The temperature of the junction (T_{j}) is related to the power dissipation and the ambient temperature (T_{a}) by the following equation:

$$T_{\text{j}} = (P_{\text{d}} \cdot \theta_{\text{ja}}) + T_{\text{a}}$$

If a heat sink is applied, the heat passes from the case to the sink before being emitted into the air. The purpose of a heat sink is to increase the effective heat-dissipation area and quickly remove heat from the device, permitting the device to work at higher power levels. The heat sink provides an additional low-thermal resistance path from case to ambient air.

Once a certain case temperature is reached, the maximum power rating drops off linearly as shown in Figure 6. This is called the derating curve. The derating factor (D_{f}) is a measure of how fast the curve drops off (i.e., the slope of the curve). Its units are in $\text{W}/^\circ\text{C}$. Derating factor (D_{f}) is the reciprocal of θ_{jc} .

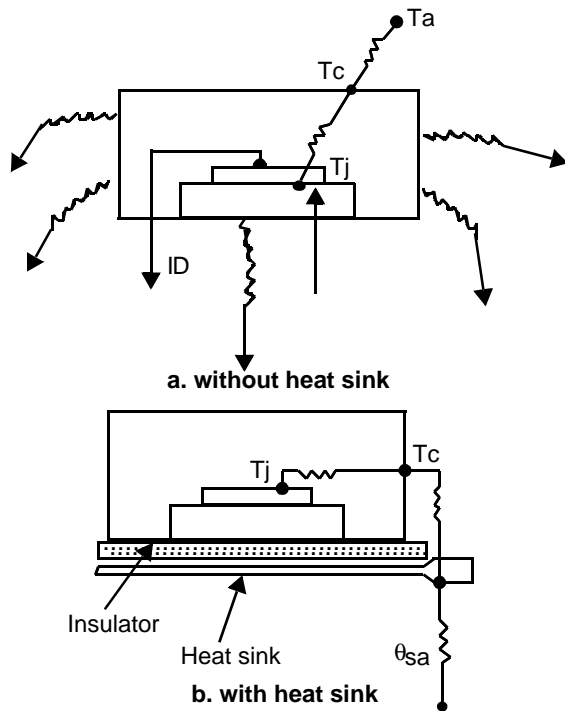
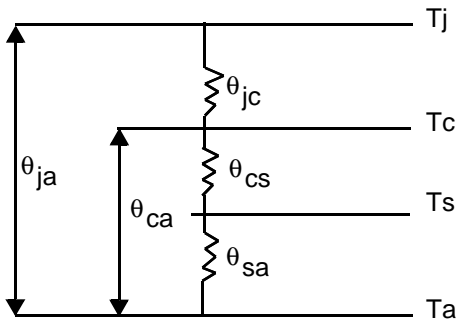

Figure 4. Heat Flow Path



Tj = Junction Temperature
 Tc = Case Temperature
 Ts = Sink Temperature
 Ta = Air Temperature

Without heat sink
 $\theta_{ja} = \theta_{jc} + \theta_{ca}$

With heat sink
 $\theta_{ja} = \theta_{jc} + \theta_{cs} + \theta_{sa}$

Figure 5. Thermal Resistance Paths (Schematic Representation)

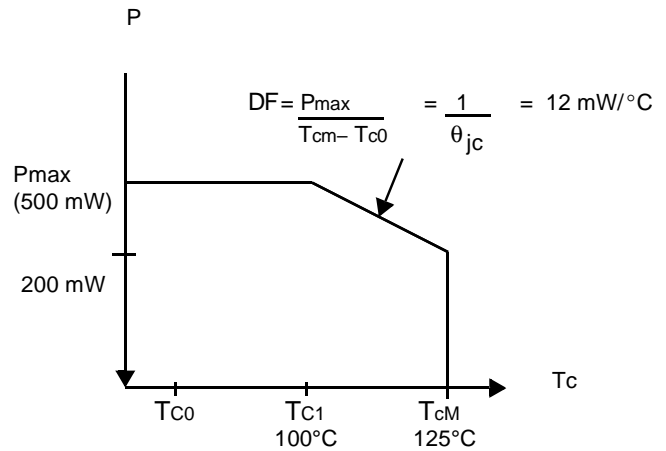

Figure 6. Derating Curve

Heat Transfer

Any discussion of heat transfer should begin with a brief overview of how heat is transferred. There are three mechanisms by which heat may be transferred: convection, radiation, and conduction.

Convection involves the transfer of heat by the mixing of fluid. It is the primary process for heat transfer from a solid to a liquid or gas in contact with it. The rate of convection heat flow is mainly a function of surface area, position of the solid in contact with the fluid, the fluids velocity and properties, and gravity force.

Thermal radiation is heat transferred by electromagnetic radiation. It exists always, but is the only means of heat transfer between entities separated by a vacuum.

Heat transfer by conduction involves the transfer of kinetic energy from one molecule to another. It is the primary mechanism for heat transfer between solids. Conduction heat transfer is governed by Fourier's law.

The thermal resistance equations, 1 and 1a, mentioned previously can be derived using Fourier's law stating that the rate of heat flow (P) through a material is proportional to the cross sectional area (A) of the material normal to the heat flow, the temperature gradient (T) along the thickness (x) of the material, and the thermal conductivity (K), a constant and a basic property of the material. The value of K is in units of W/°C-cm mathematically:

$$(2) \quad P = KA \cdot (dT/dx) = (kA/x) \cdot (T_2 - T_1)$$

expressed in units of W/cm²,

and hence:

$$(3) \quad T = \theta \cdot P \text{ where } \theta = x/KA$$

Now look at the definition of heat capacity or the time rate of heat flow.

$$P = dQ/dt$$

Where Q is the quantity of heat in calories. Thus, P equals the power dissipation in watts.

$$P = \text{cal/sec} = \text{watts}$$

Equation 3 shows that:

$$\theta = (T_2 - T_1) / Pd$$

Equation 3 illustrates that thermal resistance is a function of the geometry and thermal conductivity of the device, varying inversely with cross sectional area. Therefore, assuming that larger chip sizes are contained in larger packages, it can be concluded that the larger the device package area, the lower the thermal resistance.

This can also be shown by understanding the concept of thermal spreading. Heat spreads both laterally and vertically through the IC layers, primarily by conduction. A cross sectional view of the die mounted on a substrate package is shown in Figure 7. The spread angle varies for each type of material.

In a small package with restricted thermal spreading, more heat builds up within the package area (i.e., a higher thermal constant). While in a larger package, increasing the area beyond full spreading does not affect the thermal constant because the area normal to the heat flow does not increase.

The graph in Figure 8a shows the relationship between thermal resistance (θ) and the device package area (A). Figure 8b shows the θ /c versus the ratio of thickness (X) to the area (A).

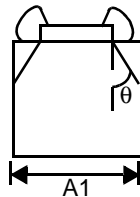

Restricted Thermal Spreading

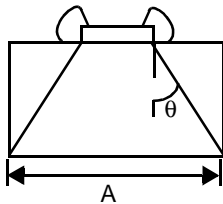

Full Thermal Spreading

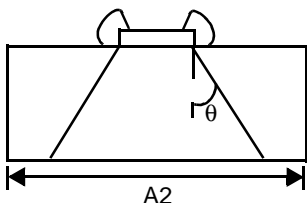
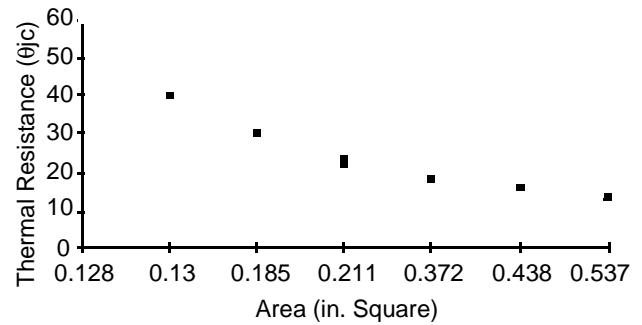
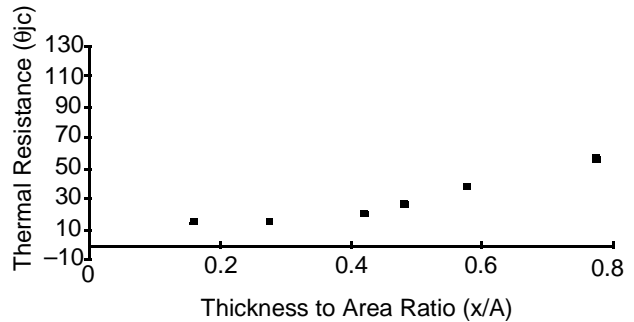

Figure 7. Spread Angles ($A_1 < A < A_2$)



a. Thermal Resistance versus Area



b. Thermal Resistance versus Thickness

Figure 8. Thermal Resistance Curves

The challenge in computing the thermal resistance of the layers of a packaged device is in finding the boundaries with which to define the area of heat. This is not an easy task because the spread angle of heat varies for each type of material, increasing with larger thermal conductivity. Table 1 shows some spread angles of various materials.

Table 1. Material Spread Angles

Material	Material Spread Angles
Silicon	40°
BeO	60°
Al ₂ O ₃	25°
Kovar	25°
Epoxy	0°
Eutectic	0°
Copper	70°
Aluminum	65°

The model thus far has provided a means for predicting thermal conditions for a constant power input. In the case of a transient response to a pulse input of power or a series of pulses, thermal capacitance is introduced. When the die is subjected to a short pulse of power, the layers below act as a thermal capacitor, absorbing and storing the thermal energy. Upon termination of the pulse, the die cools and the thermal energy is dissipated

through the layers to the case of the device. Figure 9 shows the transient response to a single heat pulse and a series of pulses to the die.

The junction temperature of a semiconductor device is related to the temperatures of the various other elements surrounding it by mathematical relationships similar to those that define the properties of an electrical circuit that contains resistance and capacitance. It is convenient, therefore, to show the thermal characteristics of a solid state device as analogous to the electrical properties of a circuit.

The flow of heat is analogous to the flow of charge; thermal resistance and capacitance are analogous to electrical resistance and capacitance; and the potential difference (voltage) between two points in an electrical circuit is analogous to temperature difference. Table 2 shows these relationships.

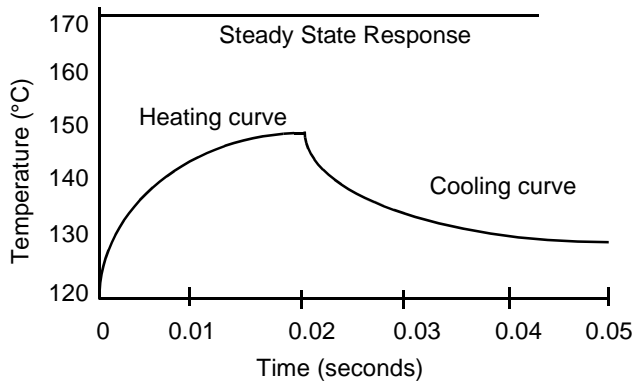

a. 20-ms Heat Pulse

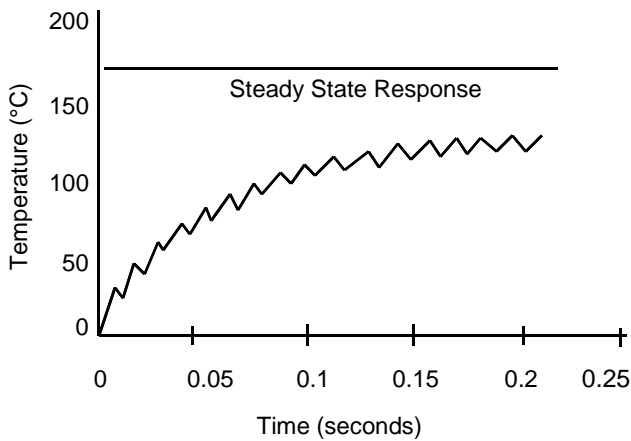

b. 9-ms Square Pulse with a 12-ms period

Figure 9. Transient Responses

Table 2. Comparison of Electrical Parameters to Analogous Thermal Parameters

Electrical		
Resistance	R	(Ohms)
Capacitance	C	Amps-s/V
Voltage	V	Volts
Current	I	Amps
Conductivity	p	Ohms/cm ²
Charge	q	Coulomb
$R_2 = \frac{V1 - V2}{P}$		
Thermal		
Thermal resistance	q	°C/W
Thermal capacitance	C	W-s/°C
Temp. difference	T	°C
Power dissipation	P	Watts
Thermal conductivity	K	W/in-°C
Quantity of heat	Q	Calories
$\theta_2 = \frac{T1 - T2}{P}$		

Table 3. Comparison of Electrical Parameters to Analogous Thermal Parameter

Electrical		
Resistance	R	(Ohms)
Capacitance	C	Amps-s/V
Voltage	V	Volts
Current	I	Amps
Conductivity	p	Ohms/cm ²
Charge	q	Coulomb
$R_2 = \frac{V1 - V2}{P}$		
Thermal		
Thermal resistance	q	°C/W
Thermal capacitance	C	W-s/°C
Temp. difference	T	°C
Power dissipation	P	Watts
Thermal conductivity	K	W/in-°C
Quantity of heat	Q	Calories
$\theta_2 = \frac{T1 - T2}{P}$		

Table 4. Comparison of Electrical Parameters to Analogous Thermal Parameters

Electrical		
Resistance	R	(Ohms)
Capacitance	C	Amps-sec/V
Voltage	V	Volts
Current	I	Amps
Conductivity	p	Ohms/cm ²
Charge	q	Coulomb
$R_2 = \frac{V_1 - V_2}{P}$		
Thermal		
Thermal resistance	q	°C/W
Thermal capacitance	C	W-sec/°C
Temp. difference	T	°C
Power dissipation	P	Watts
Thermal conductivity	K	W/in-°C
Quantity of heat	Q	Calories
$\theta_2 = \frac{T_1 - T_2}{P}$		

Thermal capacitance is equal to the product of the specific heat (H) of the material used in the sample and the mass (M) of the sample; it is the quantity of heat absorbed by the sample when its temperature rises 1°C. Therefore, if a sample absorbs a quantity of heat (Q) when its temperature is increased from T1 to T2, the thermal capacitance of the sample, expressed in watt-seconds per °C, can be determined from the following equation:

$$C = \frac{Q}{T_2 - T_1}$$

Figure 10 shows the electro-thermal circuit for a three layer device. Thermal impedance, like electrical impedance, is a complex variable because of the time dependence associated with the thermal capacitance. In this circuit, the thermal resistances closest to the heat source are large because the cross section of the semiconductor is small (all the heat flows through a small area). Thermal resistance varies inversely with cross sectional area (as shown in equation 3). Thermal resistance becomes progressively smaller as distance from the semiconductor increases.

Since thermal capacitance varies directly with both specific heat and mass, the small mass of the semiconductor causes the thermal capacitance to be smallest at the heat source and to become progressively larger as distance from the heat source increases. The final thermal capacitance in the series is considered an infinite capacitance, which is electrically equivalent to a short across the end of the line.

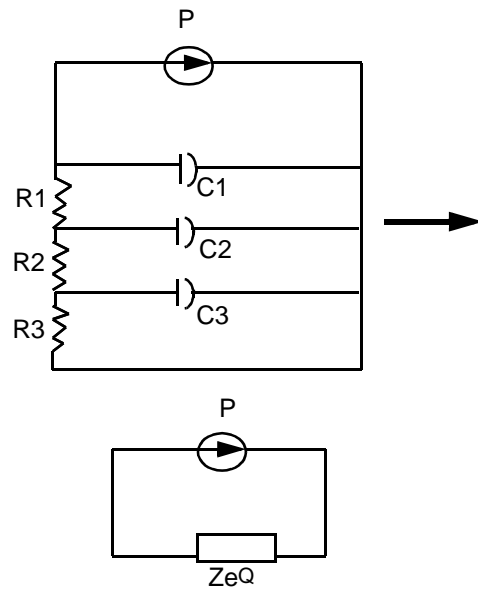

$R = x/KA$
 $C = p \cdot c \cdot v$
 p = density
 c = heat capacity
 v = volume

Figure 10. Electrothermal Circuit for a Three-Layer Device

To simplify the equation, assume a steady state condition where capacitance does not play a role. Thus, for a three-layer device (die, epoxy, and package), total thermal resistance equals three resistances in a series.

$$R_{die} + R_{epoxy} + R_{package}$$

Consider a square heat source of side dimension a in contact with a package of thickness x. For simplicity, assume that the thermal spread angle of the material is 45°. Thus, the area is the truncated pyramid and theta is calculated by the following equation:

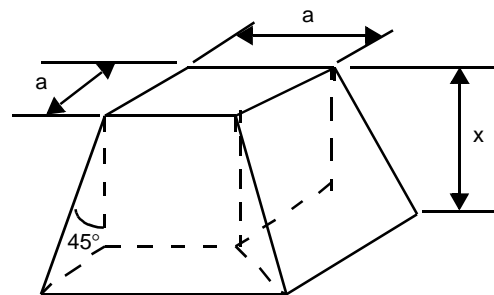

$$\theta = (1/K) \int dx / \text{area} \quad \text{area} = f(x)$$

and therefore:

$$\theta = x/[K \cdot a(a + 2x)]$$

For this example, the package material thermal conductivity equals 0.1524 W/°C-in and the thickness of 0.1 inches (100 mils). The heat source (i.e., the die) is 160 mils x 160 mils.

$$\theta_{pkg} = \frac{1}{0.1524[0.16 \cdot (0.16 + 2 \cdot (0.1))]} = 11.39^\circ\text{C/W}$$

Continuing to determine the total thermal resistance, the resistance of the die and adhesive is calculated.

Silver-filled conductive epoxy of thickness 1.0 mil, having a thermal conductivity of 0.0063 W/°C-in is used. Again, the heat source is the die of the side dimension 160 mils; however, the spread angle of the heat through epoxy is 0°. Thus,

$$\theta_{epoxy} = \frac{0.001}{(0.0063) \cdot (0.16)^2} = 6.20^\circ\text{C/W}$$

The thermal conductivity of silicon is 3.27 W/°C-in; die thickness is 20 mils and the heat source is the sum of the collector junction region totaling a dimension of approximately 10 mils.

$$\theta_{die} = \frac{0.02}{3.27[(0.01) \cdot (0.01 + 2 \cdot (0.02))]} = 12.23^\circ\text{C/W}$$

Therefore:

$$\begin{aligned} &\theta_{die} + \theta_{epoxy} + \theta_{pkg} \\ &= 12.23^\circ\text{C/W} + 6.20^\circ\text{C/W} + 11.39^\circ\text{C/W} \end{aligned}$$

$$\theta_{total} = 29.82^\circ\text{C/W}$$

A more accurate calculation of θ_{jc} would also include the lead frame and wire bonding thermal resistances as described in Figure 11.

The graphs in Figure 12 illustrate how thermal resistance varies with package area and die size. All values were calculated as described above using the dimensions of LCC packages and associated die.

Thermal Properties of Materials

Several factors affect the thermal resistance of an IC package. Package variables include leadframe material and construction, case material and construction, and die attach method and material.

Accurate information on thermal properties of materials is not readily available. The thermal conductivity of ceramics, for example, is dependent on the purity of the material, and that of silicon is dependent on temperature.

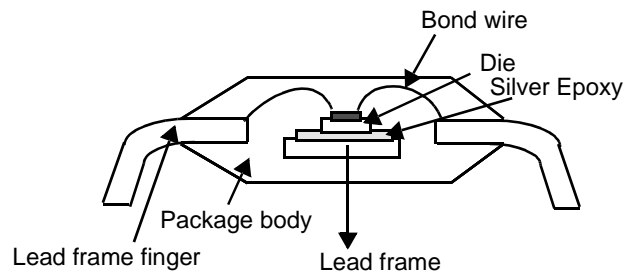
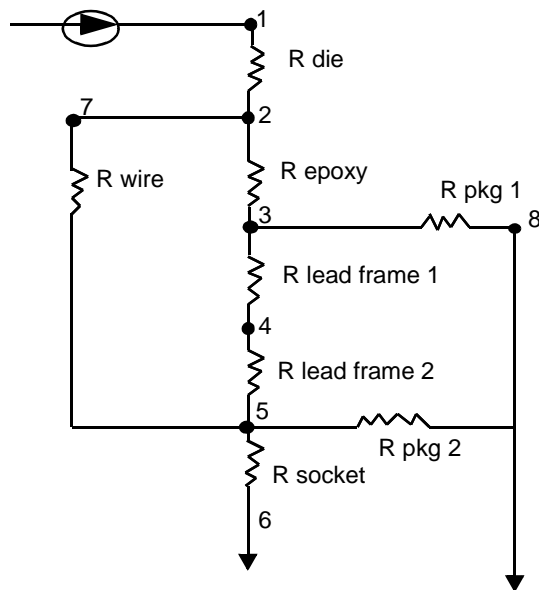

- Nodes:
1. collector junction
 2. within die under junction
 3. lead frame surface
 4. lead frame periphery
 5. lead frame finger
 6. ambient
 7. bond pads
 8. package body

Figure 11. Total Thermal Resistance

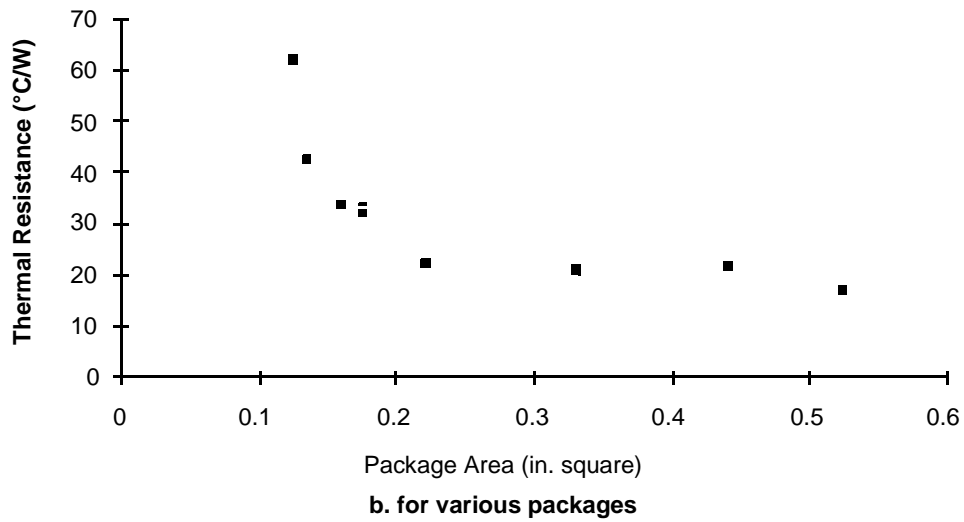
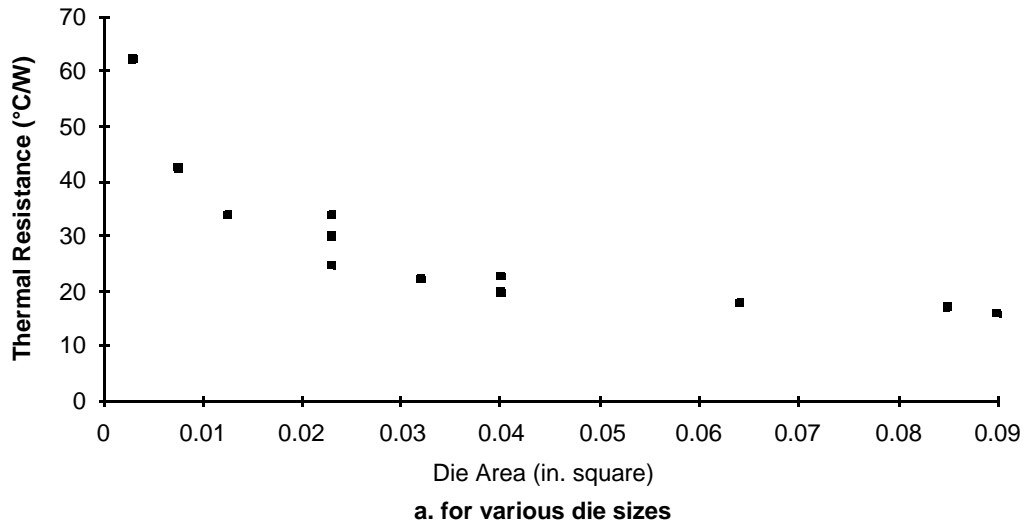

Figure 12. Calculated Thermal Resistance

Table 5 lists several materials and their thermal conductivity.

Table 5. Typical Thermal Properties of Materials

Silicon	
K = 1.05 W/cm°C	@ T = 100°C
K = 0.976 W/cm°C	@ T = 120°C
K = 1.29 W/cm°C	@ T = 25°C
Kovar	
K = 0.21 W/cm°C	@ T = 20–100°C
K = 0.134 W/cm°C	@ T = 25°C
Gold-Silicon Eutectic	
K = 2.96 W/cm°C	@ T = 25°C
K = 2.16 W/cm°C	@ T = 25°C
Beryllia	
K = 1.54 W/cm°C	@ T = 100°C
K = 2.05 W/cm°C	@ T = 20°C
K = 2.54 W/cm°C	@ T = 25°C
Conductive Silver Filled Epoxy	
K = 0.016 W/cm°C	@ T = 120°C
Alumina (90–92%)	
K = 0.06 W/cm°C	@ T = 25°C
K = 0.07 W/cm°C	@ T = 100°C
Solder	
K = 0.492 W/cm°C	@ T = 25°C
Sapphire	
K = 0.033 W/cm°C	@ T = 38°C
K = 0.026 W/cm°C	@ T = 93°C
K = 0.023 W/cm°C	@ T = 149°C