

YAC512

2-Channel Floating D/A Converter

■ OUTLINE

The YAC512 is a floating D/A converter with 10-bit mantissa and 7-step exponent.

It can produce analog output of 16-bit dynamic range.

It is suitable for YMF262 (OPL3) and other stereo sound source LSI.

■ FEATURES

- 2-channel floating D/A converter.
- 16-bit dynamic range.
- 16-bit digital data is converted to floating data internally.
- Analog output is easily available by external buffer operational amplifiers.
- Built-in analog switches for sample-hold.
- Si-gate C-MOS process and accurate thin film resistor.
- 5V single power supply.
- 16-pin plastic SOP (YAC512-M).

■ PIN CONFIGURATION

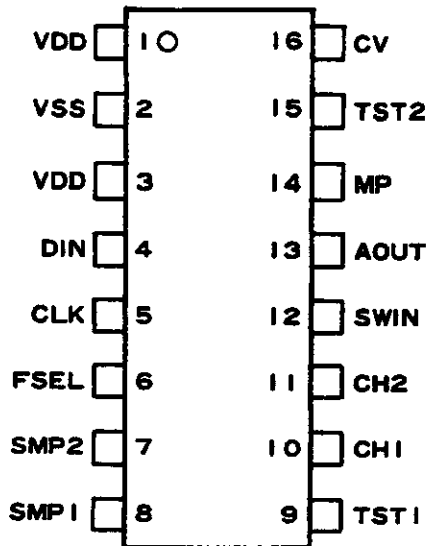

< 16SOP Top View >

■ PIN FUNCTION

No.	Name	I/O	Function
1	VDD	—	+5V power supply
2	VSS	—	Ground
3	VDD	—	+5V power supply
4	DIN	I	Digital data input serial data
5	CLK	I	bit clock
6	FSEL	I	Data format select ('H'; offset binary, 'L'; 2's complement)
7	SMP2	I	Digital data input CH1 latch/CH2 sample signal
8	SMP1	I	CH2 latch/CH1 sample signal
9	TST1	I	LSI test terminal (connect to VDD terminal normally)
10	CH1	OA	Analog switch CH1 output
11	CH2	OA	Analog switch CH2 output
12	SWIN	IA	Analog switch CH1/CH2 common input
13	AOUT	OA	CH1/CH2 analog output (connect to SWIN terminal via OP-AMP.)
14	MP	IA	Analog shifter reference voltage input (bias with 1/2VDD)
15	TST2	O	LSI test terminal (disconnect normally)
16	CV	-A	DAC center voltage terminal (connect to MP terminal via OP-AMP.)

Note) A; Analog terminal

■ BLOCK DIAGRAM

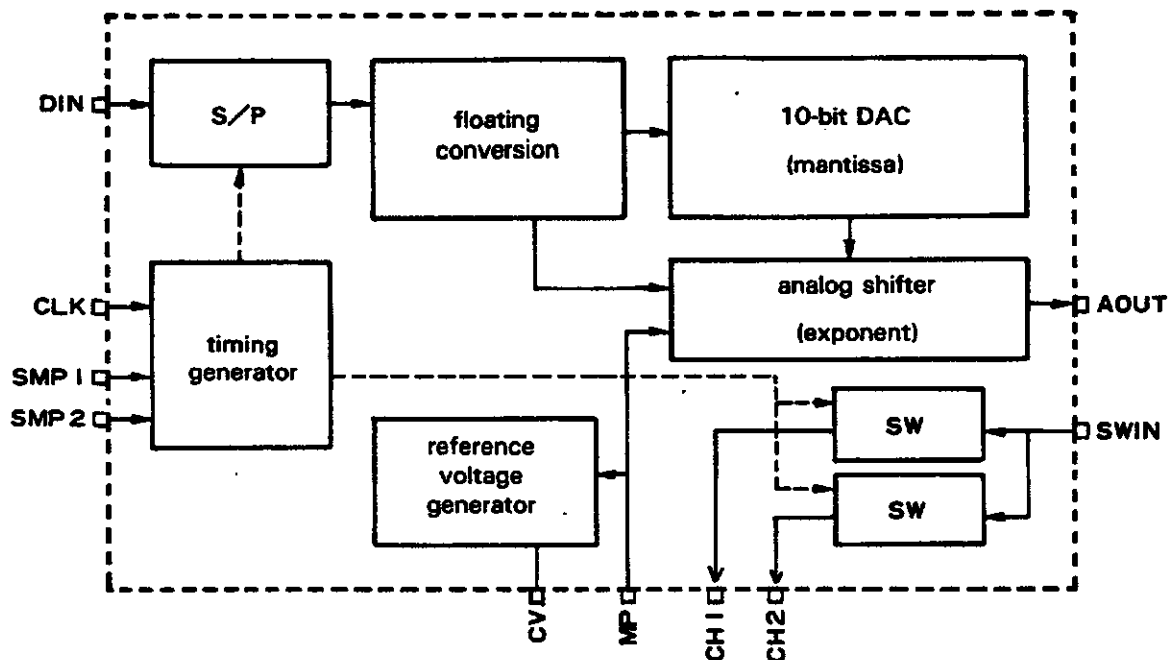

■ FUNCTION DESCRIPTION

16-bit serial data synchronized with CLK clock is inputted to DIN terminal and latched when SMP1 and SMP2 fall.

Inputted data is converted to floating data and its mantissa and exponent are sent to 10-bit DAC and 7-step analog shifter respectively.

D/A voltage determined by this floating data is outputted from AOUT terminal and inputted to SWIN terminal via buffer operational amplifier for sample-hold.

Built-in CH1 (CH2) analog switch is ON when SMP1='H' (SMP2='H') and analog signals are outputted to CH1 and CH2 terminal.

CH1 (CH2) output voltage is held with external capacitor connected to CH1 (CH2) terminal when SMP1='L' (SMP2='L').

CV terminal voltage is $1/2V_{DD}$ determined by internal resistors.

Put $10\mu F$ external capacitor for stabilizing and connect CV to MP terminal via operational amplifier.

■ INPUT FORMAT

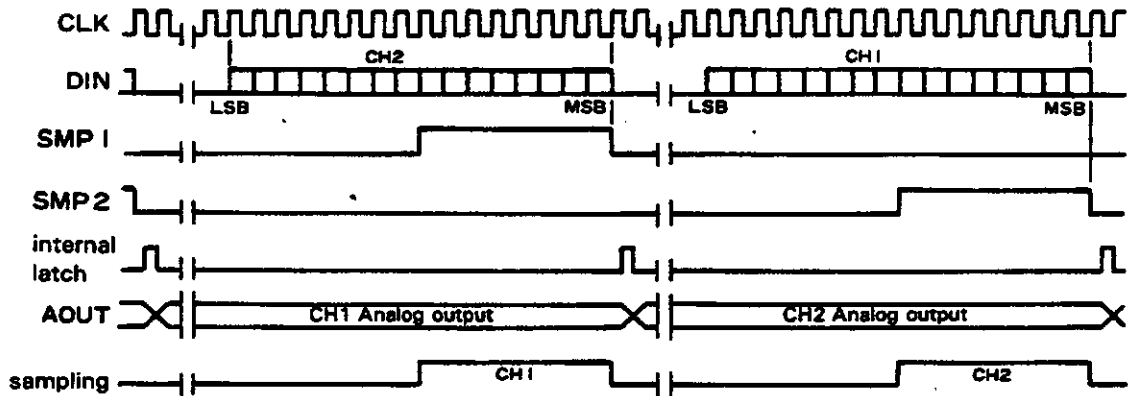

■ SAMPLE CIRCUIT

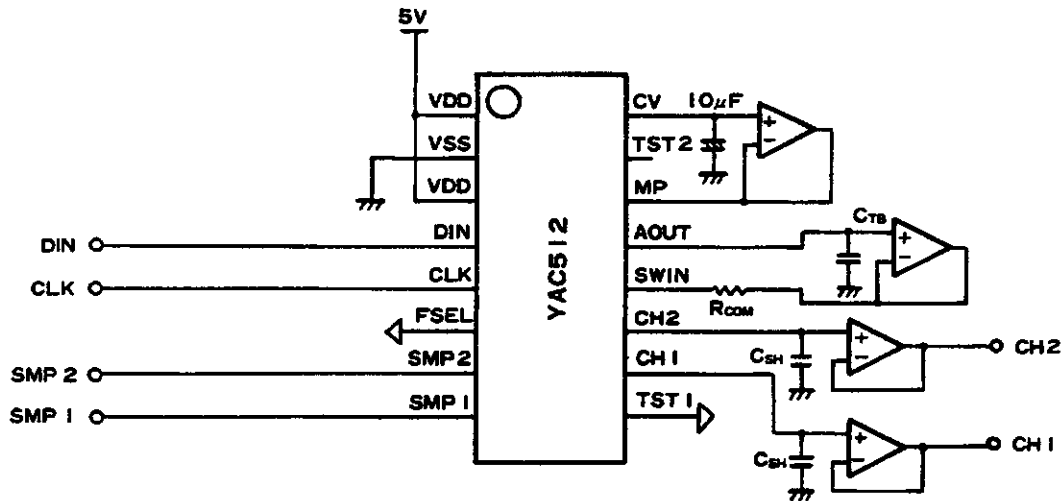

● Recommended conditions

- (1) Use regulated and low output impedance power supply such as 78 × 05 series regulator.
- (2) NJM4560, NJM2100 and compatible buffer OP-AMPs are recommended.

offset: within ±2.0mV
through rate: 4V/µs or more

(3) Recommended circuit values

CSH=2700pF (sample-hold capacitor)
CTB=33~68pF
Rcom=33Ω

■ ELECTRICAL CHARACTERISTICS

1. Absolute Maximum Ratings

Parameter	Symbol	Rating	Unit
Power supply voltage	VDD	-0.3-7.0	V
Input voltage	VI	-0.3-VDD+0.3	V
Operating voltage	Top	0-70	°C
Storing temperature	Tstg	-50-125	°C

2. Recommended Operating Conditions

Parameter	Symbol	Min.	Typ.	Max.	Unit
Power supply voltage	VDD	4.75	5.00	5.25	V
Operating voltage	Top	0	25	70	°C

3. DC Characteristics (Conditions; Ta=0-70°C, VDD=5.0±0.25V)

Parameter	Symbol	Condition	Min.	Typ.	Max.	Unit
Power consumption	W	VDD=5.0V			30	mW
Input voltage H level	VIH	*1	0.66VDD			V
Input voltage L level	VIL	*1			0.30VDD	V
Input leakage current	ILK	*1			0.001	μA
Input capacitance	CI	*1			5	pF

*1) Applicable to CLK, DIN, SMP1, SMP2

4. DC Characteristics (Conditions; Ta=0-70°C, VDD=5.0±0.25V)

Parameter	Symbol	Min.	Typ.	Max.	Unit
CLK clock frequency	fc	0.65	3.2	6.0	MHz
H level time	tH	100			ns
rise time	tr			30	ns
fall time	tf			30	ns
DIN, SMP1, SMP2					
setup time	tDS	50			ns
transition time	tDT			30	ns

• CLK timing

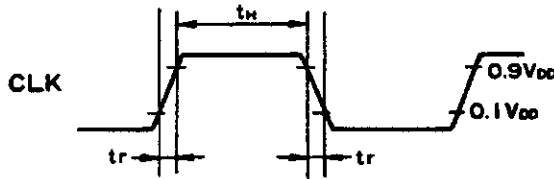

• DIN, SMP1, SMP2 timing

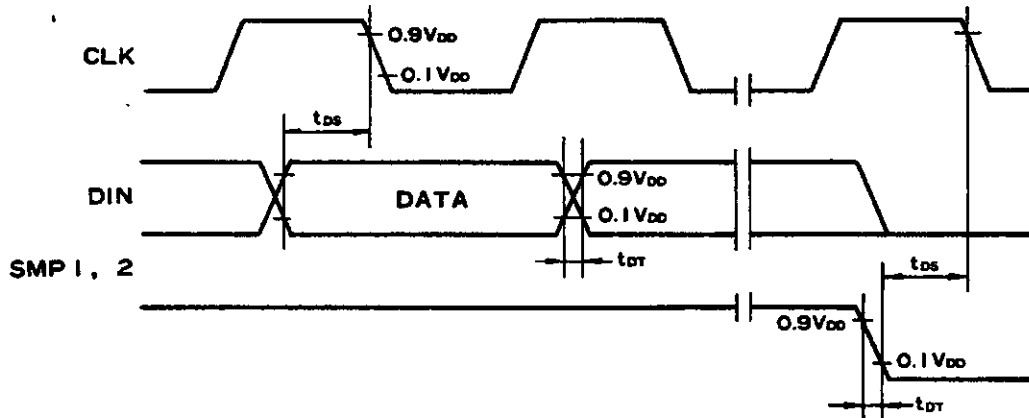

5. Analog Characteristics (Conditions: $T_a=25^\circ\text{C}$, $V_{DD}=5.0\text{V}$, measured by sample circuit)

Parameter	Symbol	Condition	Min.	Typ.	Max.	Unit
Maximum output amplitude	VO			2.5		V
Total harmonic distortion	THD 0	1 KHz, 0dB		0.09	0.18	%
	THD20	1 KHz, -20dB		0.07	0.20	%
	THD40	1 KHz, -40dB		0.25	0.65	%
Dynamic range	DR			16		bit
Signal noise ratio	S/N	1 KHz, 0dB		86		dB
Cross talk	CT	1 KHz, 0dB		-72		dB

EXTERNAL DIMENSIONS

●YAC512-M

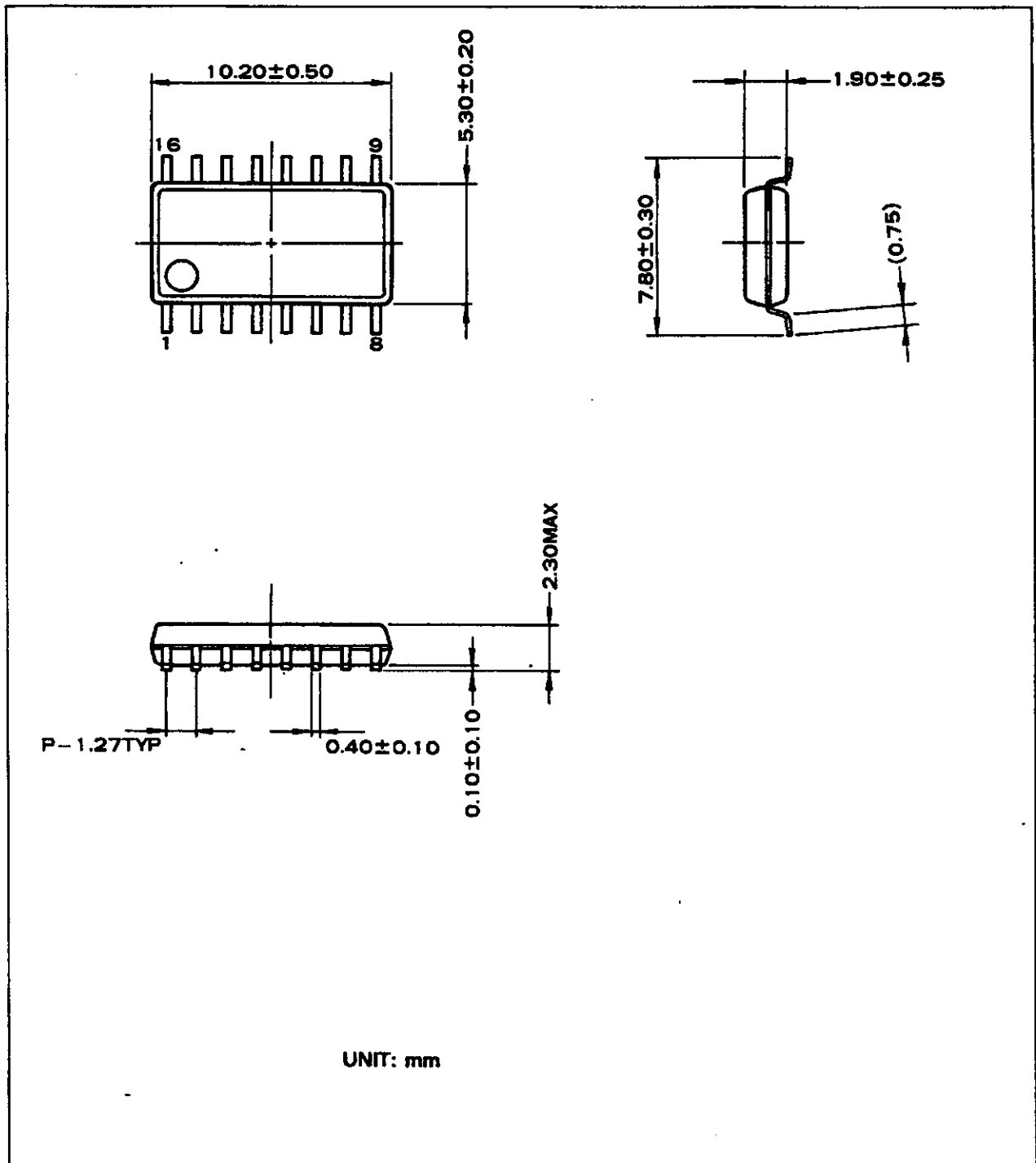

The specifications of this product are subject to improvement changes without prior notice.

AGENCY

YAMAHA CORPORATION

Address inquiries to:

Semi-conductor Sales Department

- **Head Office** 203, Matsumokijima, Toyooka-mura,
Iwata-gun, Shizuoka-ken, 438-01
Electronic Equipment business section
Tel. 0539-62-4918 Fax. 0539-62-5054
- **Tokyo Office** 2-17-11, Takanawa, Minato-ku,
Tokyo, 108
Tel. 03-5488-5431 Fax. 03-5488-5088
- **Osaka Office** 3-12-9, Minami Senba, Chuo-ku,
Osaka City, Osaka, 542
Shinsuibashi Plaza Bldg. 4F
Tel. 06-252-7980 Fax. 06-252-5615
- **U.S.A. Office** YAMAHA Systems Technology,
100 Century Center Court, San Jose, CA95112
Tel. 408-467-2300 Fax. 408-437-8791