

2578 - \* - \* \* \*  
 MATERIAL CODE  
 (.28)/.0106 THK  
 BLANK=BRASS  
 B=PHOS BRONZE  
 WINDING SPEC.  
 A=CHAIN, PER WINDING DETAIL "A"  
 BLANK=CHAIN, PER WINDING DETAIL "B"  
 L=LOOSE  
 PLATING CODE  
 (PER SDES-88)

OPTIONS  
 BLANK=AS SHOWN  
 1 = WITH CAT EARS

- (122) - OVERALL TIN: (0.00381)/.000150 MIN. OVER (0.00076)/.000030 MIN. NICKEL
- (154) - OVERALL TIN (0.00254)/.000100 MIN. OVER (0.00127)/.000050 MIN. NICKEL
- (224) - OVERALL MATTE TIN: (0.00508)/.000200 MIN. OVER (0.00127)/.000050 MIN. NICKEL
- (550) - SELECT GOLD: (0.00038)/.000015 MIN. OVERALL GOLD FLASH: (0.00005)/.000002 MIN. OVERALL NICKEL UNDERPLATE: (0.00076)/.000030 MIN.
- (555) - SELECT GOLD: (0.00038)/.000015 MIN. OVERALL NICKEL UNDERPLATE: (0.00076)/.000030 MIN.
- (558) - SELECT GOLD: (0.00076)/.000030 MIN. OVERALL GOLD FLASH: (0.00005)/.000002 MIN. OVERALL NICKEL UNDERPLATE: (0.00127)/.000050 MIN.
- (P909) - OVERALL HOT TIN DIP: (0.00254)/.000100 MIN

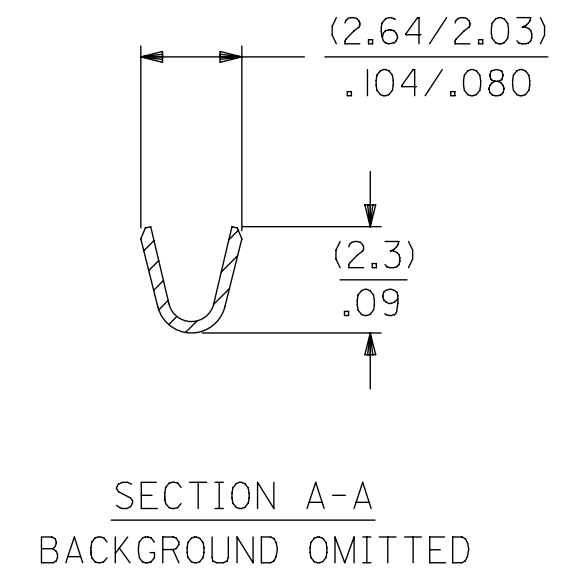
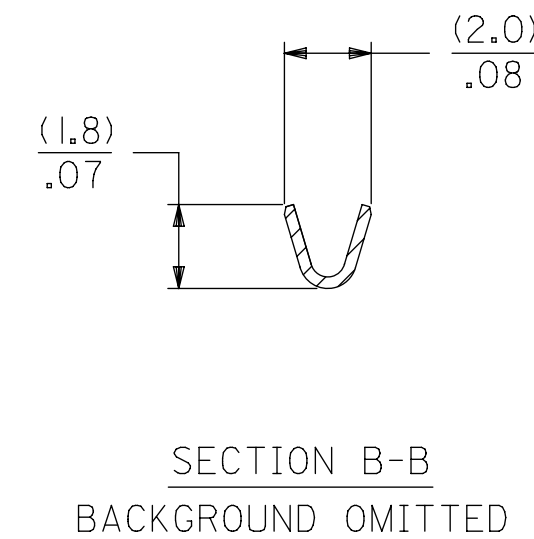
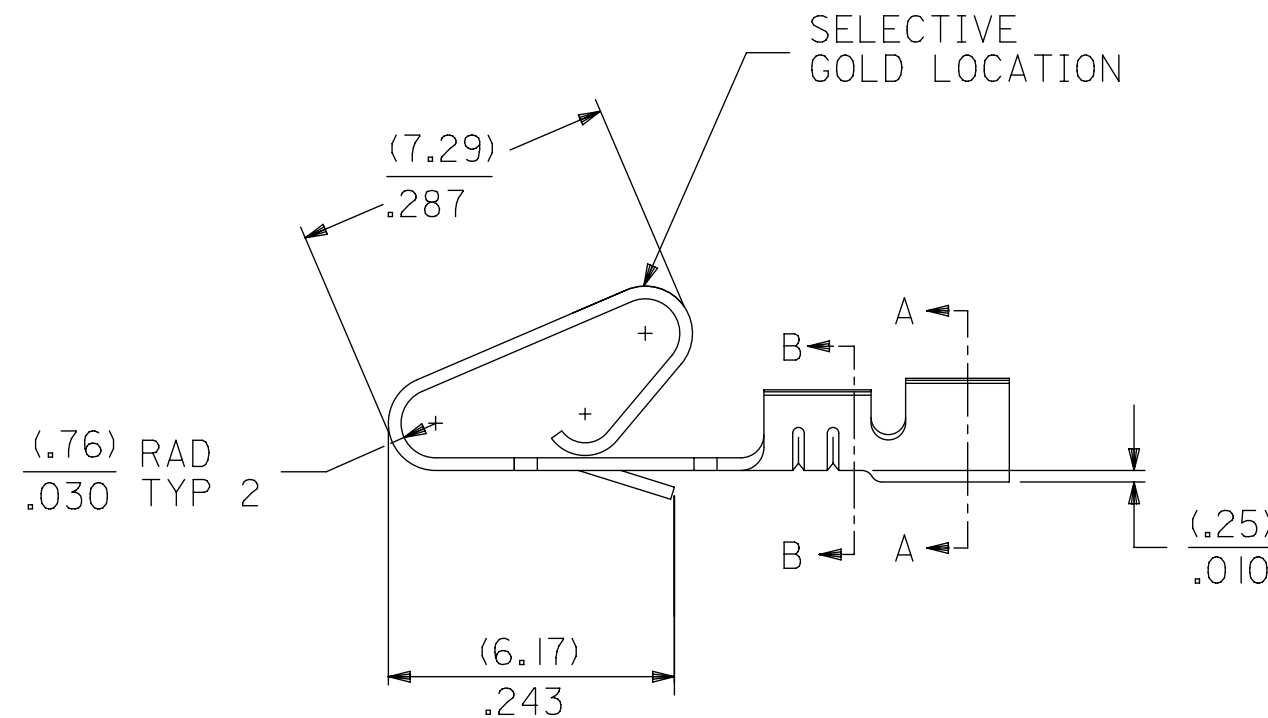
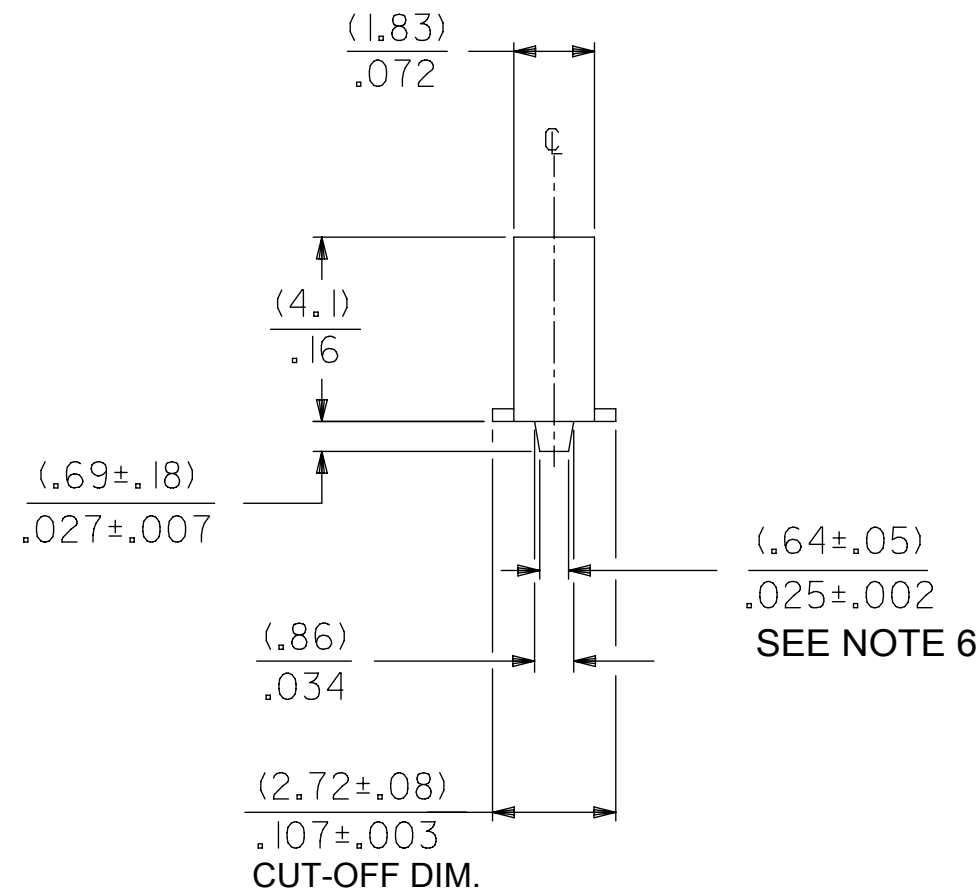

1. MATERIAL: SEE LEGEND
2. FINISH: SEE LEGEND
3. PRODUCT SPECIFICATION: PS-08-50  
 PACKAGING SPECIFICATION: LOOSE TERMINALS PER PK-2759-001  
 CHAIN FORM TERMINALS PER PK-2759-002
4. CRIMP ACCEPTS 22 TO 26 GA. WIRE WITH (1.65)/0.65 MAX INSULATION DIA
5. DIMENSIONS GIVEN ACROSS CENTERLINES ARE SYMMETRICAL ABOUT THOSE CENTERLINES WITHIN HALF THE TOTAL TOLERANCE
6. OPTIONAL DESIGN (.86 ± .05)/.034 ± .002
7. THIS PART CONFORMS TO CLASS B REQUIREMENTS OF COSMETIC SPECIFICATION PS-45499-002

THIS DRAWING CONTAINS INFORMATION THAT IS PROPRIETARY TO MOLEX ELECTRONIC TECHNOLOGIES, LLC AND SHOULD NOT BE USED WITHOUT WRITTEN PERMISSION									
SYMBOLS		DIMENSION UNITS		SCALE		CURRENT REV DESC: NOTE 3 UPDATED			
▽ = 0	MM/IN	1:1							
▽ = 0	GENERAL TOLERANCES (UNLESS SPECIFIED)								
▽ = 0		MM	INCH						
▽ = 0	4 PLACES	±	±	EC NO: 605479					
▽ = 0	3 PLACES	±	± 0.01	DRWN: SS06		2018/09/11			
▽ = 0	2 PLACES	± 0.25	± 0.014	CHK'D: ISHWARG		2018/10/05			
▽ = 0	1 PLACE	± 0.36	±	APPR: ISHWARG		2018/10/05			
▽ = 0	0 PLACES	±	±	INITIAL REVISION:					
▽ = 0	ANGULAR TOL	± 0.5°		DRWN: PEREZ/AR		1987/01/29			
▽ = 0	DRAFT WHERE APPLICABLE MUST REMAIN WITHIN DIMENSIONS			APPR: FSMITH		2014/04/21			
		THIRD ANGLE PROJECTION		DRAWING		SERIES		MATERIAL NUMBER	
		C-SIZE		2578		SEE CHART		CUSTOMER	
						GENERAL MARKET		SHEET NUMBER	
								1 OF 2	

**molex**

CRIMP TERMINAL  
 (3.96)/.156 CENTERS 22 TO 26 GA WIRE

PRODUCT CUSTOMER DRAWING

DOCUMENT NUMBER: SD-2578  
 DOC TYPE: PSD  
 DOC PART: 001  
 REVISION: Y1

