

## 82433LX/82433NX LOCAL BUS ACCELERATOR (LBX)

- Supports the Full 64-bit Pentium™ Processor Data Bus at Frequencies up to 66 MHz (82433LX and 82433NX)
- Drives 3.3V Signal Levels on the CPU Data and Address Buses (82433NX)
- Provides a 64-Bit Interface to DRAM and a 32-Bit Interface to PCI
- Five Integrated Write Posting and Read Prefetch Buffers Increase CPU and PCI Performance
  - CPU-to-Memory Posted Write Buffer 4 Qwords Deep
  - PCI-to-Memory Posted Write Buffer Two Buffers, 4 Dwords Each
  - PCI-to-Memory Read Prefetch Buffer 4 Qwords Deep
  - CPU-to-PCI Posted Write Buffer 4 Dwords Deep
  - CPU-to-PCI Read Prefetch Buffer 4 Dwords Deep
- CPU-to-Memory and CPU-to-PCI Write Posting Buffers Accelerate Write Performance
- Dual-Port Architecture Allows Concurrent Operations on the Host and PCI Buses
- Operates Synchronously to the CPU and PCI Clocks
- Supports Burst Read and Writes of Memory from the Host and PCI Buses
- Sequential CPU Writes to PCI Converted to Zero Wait-State PCI Bursts with Optional TRDY# Connection
- Byte Parity Support for the Host and Memory Buses
  - Optional Parity Generation for Host to Memory Transfers
  - Optional Parity Checking for the Secondary Cache
  - Parity Checking for Host and PCI Memory Reads
  - Parity Generation for PCI to Memory Writes
- 160-Pin QFP Package

Two 82433LX or 82433NX Local Bus Accelerator (LBX) components provide a 64-bit data path between the host CPU/Cache and main memory, a 32-bit data path between the host CPU bus and PCI Local Bus, and a 32-bit data path between the PCI Local Bus and main memory. The dual-port architecture allows concurrent operations on the host and PCI Buses. The LBXs incorporate three write posting buffers and two read prefetch buffers to increase CPU and PCI performance. The LBX supports byte parity for the host and main memory buses. The 82433NX is intended to be used with the 82434NX PCI/Cache/Memory Controller (PCMC). The 82433LX is intended to be used with the 82434LX PCMC. During bus operations between the host, main memory and PCI, the PCMC commands the LBXs to perform functions such as latching address and data, merging data, and enabling output buffers. Together, these three components form a "Host Bridge" that provides a full function dual-port data path interface, linking the host CPU and PCI bus to main memory.

This document describes both the 82433LX and 82433NX. Shaded areas, like this one, describe the 82433NX operations that differ from the 82433LX.

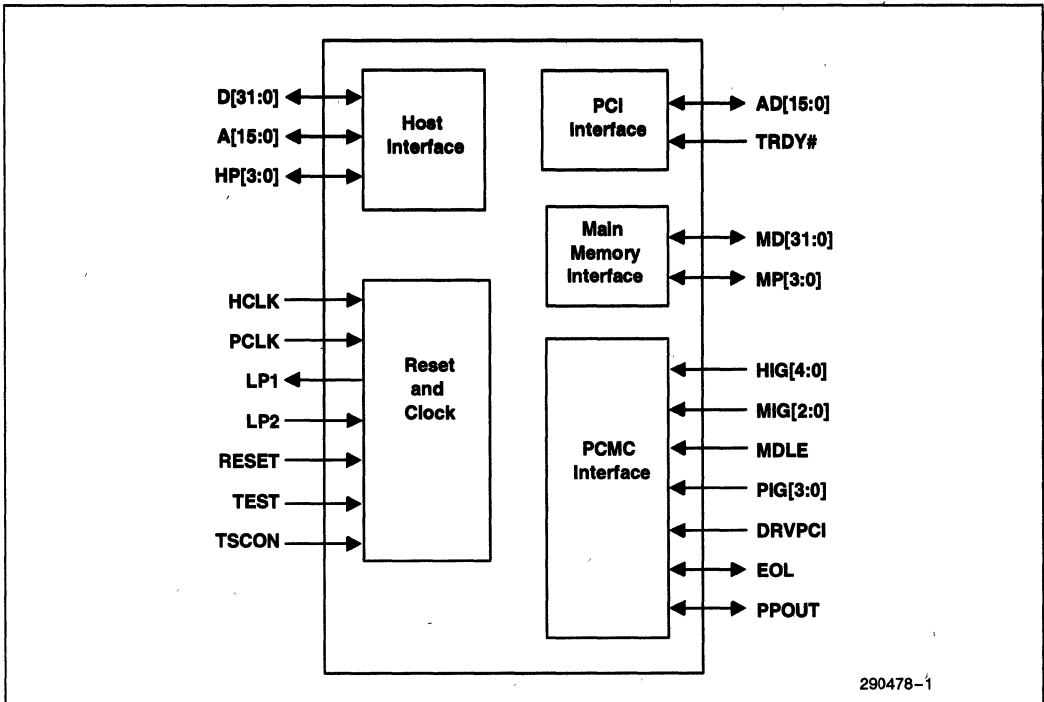

LBX Simplified Block Diagram

2

# 82433LX/82433NX LOCAL BUS ACCELERATOR (LBX)

<b>CONTENTS</b>	<b>PAGE</b>
<b>1.0 ARCHITECTURAL OVERVIEW</b> .....	2-164
1.1 Buffers in the LBX .....	2-164
1.2 Control Interface Groups .....	2-166
1.3 System Bus Interconnect .....	2-166
1.4 PCI TRDY # Interface .....	2-167
1.5 Parity Support .....	2-167
<b>2.0 SIGNAL DESCRIPTIONS</b> .....	2-167
2.1 Host Interface Signals .....	2-168
2.2 Main Memory (DRAM) Interface Signals .....	2-169
2.3 PCI Interface Signals .....	2-169
2.4 PCMC Interface Signals .....	2-169
2.5 Reset and Clock Signals .....	2-170
<b>3.0 FUNCTIONAL DESCRIPTION</b> .....	2-171
3.1 LBX Post and Prefetch Buffers .....	2-171
3.1.1 CPU-TO-MEMORY POSTED WRITE BUFFER .....	2-171
3.1.2 PCI-TO-MEMORY POSTED WRITE BUFFER .....	2-171
3.1.3 PCI-TO-MEMORY READ PREFETCH BUFFER .....	2-171
3.1.4 CPU-TO-PCI POSTED WRITE BUFFER .....	2-172
3.1.5 CPU-TO-PCI READ PREFETCH BUFFER .....	2-173
3.2 LBX Interface Command Descriptions .....	2-173
3.2.1 HOST INTERFACE GROUP: HIG[4:0] .....	2-173
3.2.2 MEMORY INTERFACE GROUP: MIG[2:0] .....	2-177
3.2.3 PCI INTERFACE GROUP: PIG[3:0] .....	2-178
3.3 LBX Timing Diagrams .....	2-180
3.3.1 HIG[4:0] COMMAND TIMING .....	2-180
3.3.2 HIG[4:0] MEMORY READ TIMING .....	2-181
3.3.3 MIG[2:0] COMMAND .....	2-182
3.3.4 PIG[3:0] COMMAND, DRVPCI, AND PPOUT TIMING .....	2-183
3.3.5 PIG[3:0]: READ PREFETCH BUFFER COMMAND TIMING .....	2-184
3.3.6 PIG[3:0]: END-OF-LINE WARNING SIGNAL: EOL .....	2-186
3.4 PLL Loop Filter Components .....	2-188
3.5 PCI Clock Considerations .....	2-189

# CONTENTS

PAGE

<b>4.0 ELECTRICAL CHARACTERISTICS</b> .....	2-190
4.1 Absolute Maximum Ratings .....	2-190
4.2 Thermal Characteristics .....	2-190
4.3 DC Characteristics .....	2-191
4.3.1 82433LX LBX DC CHARACTERISTICS .....	2-191
4.3.2 82433NX LBX DC CHARACTERISTICS .....	2-192
4.4 82433LX AC Characteristics .....	2-194
4.4.1 HOST AND PCI CLOCK TIMING, 66 MHz (82433LX) .....	2-194
4.4.2 COMMAND TIMING, 66 MHz (82433LX) .....	2-195
4.4.3 ADDRESS, DATA, TRDY#, EOL, TEST, TSCON AND PARITY TIMING, 66 MHz (82433LX) .....	2-196
4.4.4 HOST AND PCI CLOCK TIMING, 60 MHz (82433LX) .....	2-197
4.4.5 COMMAND TIMING, 60 MHz (82433LX) .....	2-197
4.4.6 ADDRESS, DATA, TRDY#, EOL, TEST, TSCON AND PARITY TIMING, 60 MHz (82433LX) .....	2-198
4.4.7 TEST TIMING (82433LX) .....	2-199
4.5 82433NX AC Characteristics .....	2-199
4.5.1 HOST AND PCI CLOCK TIMING (82433NX) .....	2-199
4.5.2 COMMAND TIMING (82433NX) .....	2-200
4.5.3 ADDRESS, DATA, TRDY#, EOL, TEST, TSCON AND PARITY TIMING (82433NX) .....	2-200
4.5.4 TEST TIMING (82433NX) .....	2-201
4.5.5 TIMING DIAGRAMS .....	2-202
<b>5.0 PINOUT AND PACKAGE INFORMATION</b> .....	2-204
5.1 Pin Assignment .....	2-204
5.2 Package Information .....	2-209
<b>6.0 TESTABILITY</b> .....	2-210
6.1 NAND Tree .....	2-210
6.1.1 TEST VECTOR TABLE .....	2-210
6.1.2 NAND TREE TABLE .....	2-210
6.2 PLL Test Mode .....	2-212

2

## 1.0 ARCHITECTURAL OVERVIEW

The 82430 PCiset consists of the 82434LX PCMC and 82433LX LBX components plus either a PCI/ISA bridge or a PCI/EISA bridge. The 82430NX PCiset consists of the 82434NX PCMC and 82433NX LBX components plus either a PCI/ISA bridge or a PCI/EISA bridge. The PCMC and LBX provide the core cache and main memory architecture and serves as the Host/PCI bridge. An overview of the PCMC follows the system overview section.

The Local Bus Accelerator (LBX) provides a high performance data and address path for the 82430LX/82430NX PCiset. The LBX incorporates five integrated buffers to increase the performance of the Pentium processor and PCI master devices. Two LBXs in the system support the following areas:

1. 64-bit data and 32-bit address bus of the Pentium processor.

2. 32-bit multiplexed address/data bus of PCI.
3. 64-bit data bus of the main memory.

In addition, the LBXs provide parity support for the three areas noted above (discussed further in Section 1.4).

### 1.1 Buffers in the LBX

The LBX components have five integrated buffers designed to increase the performance of the Host and PCI Interfaces of the 82430LX/82430NX PCiset.

With the exception of the PCI-to-Memory write buffer and the CPU-to-PCI write buffer, the buffers in the LBX store data only, addresses are stored in the PCMC component.

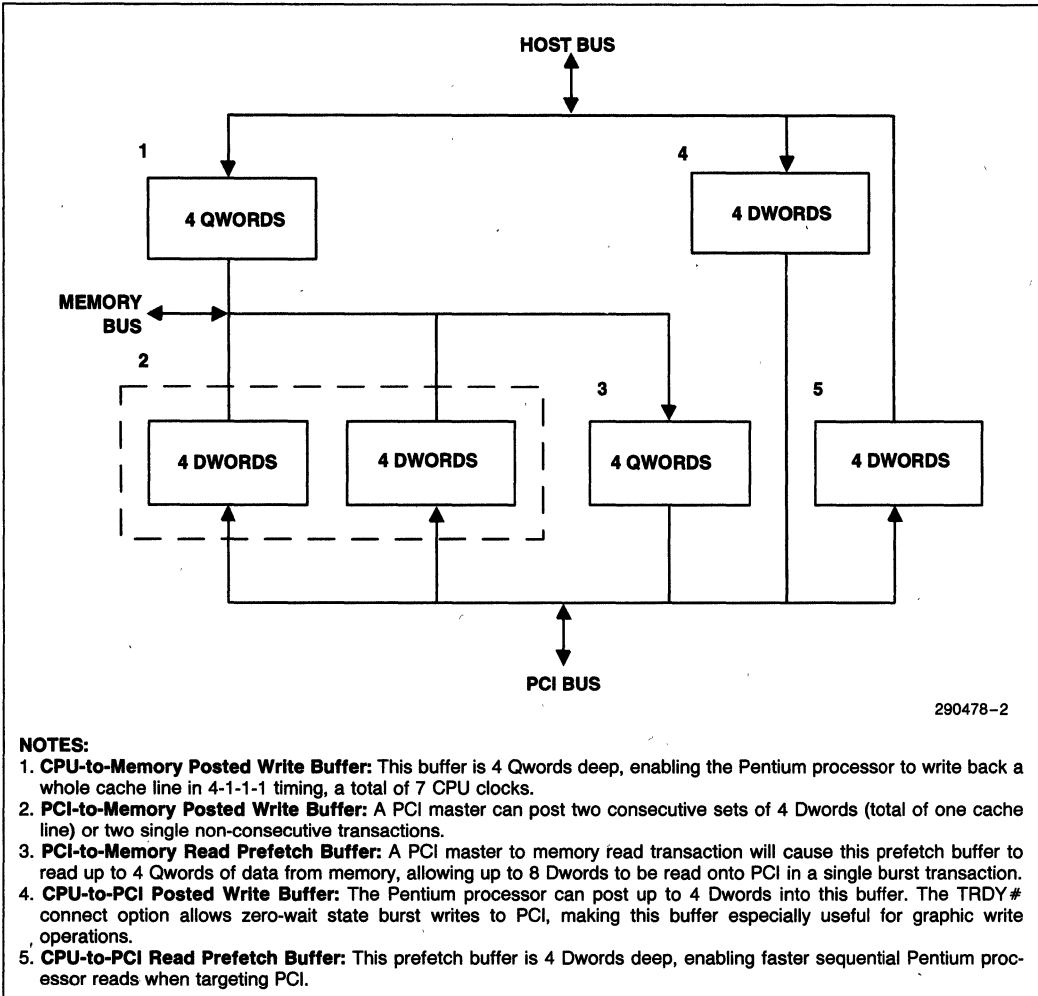

Figure 1. Simplified Block Diagram of the LBX Data Buffers

## 1.2 Control Interface Groups

The LBX is controlled by the PCMC via the control interface group signals. There are three interface groups: Host, Memory, and PCI. These control groups are signal lines that carry binary codes which the LBX internally decodes in order to implement specific functions such as latching data and steering data from PCI to memory. The control interfaces are described below.

1. **Host Interface Group:** These control signals are named HIG[4:0] and define a total of 29 (30 for the 82433NX) discrete commands. The PCMC sends HIG commands to direct the LBX to perform functions related to buffering and storing host data and/or address.
2. **Memory Interface Group:** These control signals are named MIG[2:0] and define a total of 7 discrete commands. The PCMC sends MIG commands to direct the LBX to perform functions related to buffering, storing, and retiring data to memory.
3. **PCI Interface Group:** These control signals are named PIG[3:0] and define a total of 15 discrete commands. The PCMC sends PIG commands to direct the LBX to perform functions related to buffering and storing PCI data and/or address.

## 1.3 System Bus Interconnect

The architecture of the 82430/82430NX PCIs set splits the 64-bit memory and host data buses into logical halves in order to manufacture LBX devices with manageable pin counts. The two LBXs interface to the 32-bit PCI AD[31:0] bus with 16 bits each. Each LBX connects to 16 bits of the AD[31:0] bus and 32-bits of both the MD[0:63] bus and the D[0:63] bus. The lower order LBX (LBXL) connects to the low word of the AD[31:0] bus, while the high order LBX (LBXH) connects to the high word of the AD[31:0] bus.

Since the PCI connection for each LBX falls on 16-bit boundaries, each LBX does not simply connect to either the low Dword or high Dword of the Qword memory and host buses. Instead, the low order LBX buffers the first and third words of each 64-bit bus while the high order LBX buffers the second and fourth words of the memory and host buses.

As shown in Figure 2, LBXL connects to the first and third words of the 64-bit main memory and host data buses. The same device also drives the first 16 bits of the host address bus, A[15:0]. The LBXH device connects to the second and fourth words of the 64-bit main memory and host data buses. Correspondingly, LBXH drives the remaining 16 bits of the host address bus, A[31:16].

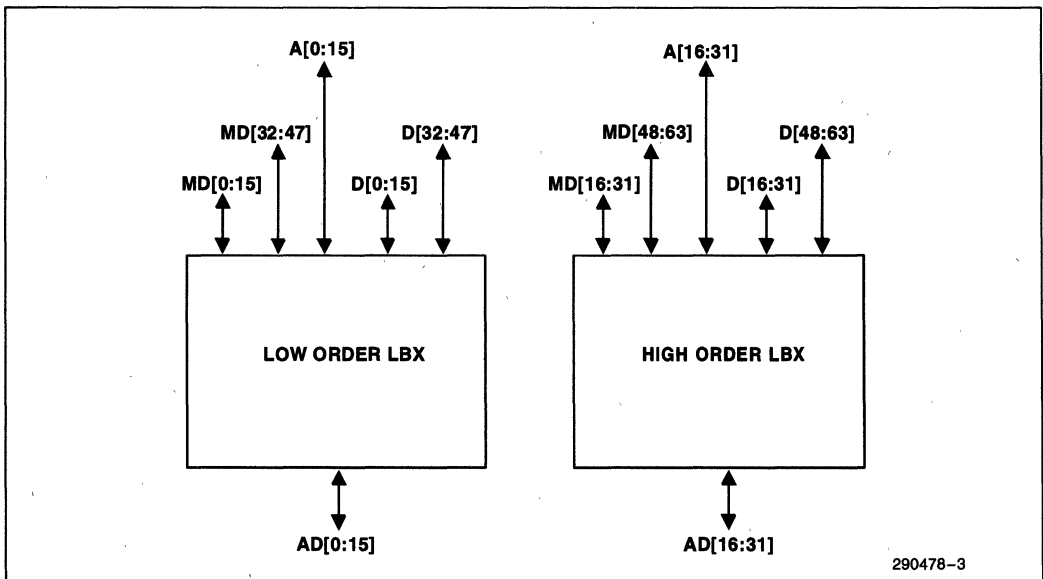

Figure 2. Simplified Interconnect Diagram of LBXs to System Buses

### 1.4 PCI TRDY# Interface

The PCI control signals do not interface to the LBXs, instead these signals connect to the 82434LX PCMC component. The main function of the LBXs PCI interface is to drive address and data onto PCI when the CPU targets PCI and to latch address and data when a PCI master targets main memory.

The TRDY# option provides the capability for zero-wait state performance on PCI when the Pentium processor performs sequential writes to PCI. This option requires that PCI TRDY# be connected to each LBX, for a total of two additional connections in the system. These two TRDY# connections are in addition to the single TRDY# connection that the PCMC requires.

### 1.5 Parity Support

The LBXs support byte parity on the host bus (CPU and second level cache) and main memory buses (local DRAM). The LBXs support parity during the address and data phases of PCI transactions to/from the host bridge.

### 2.0 SIGNAL DESCRIPTIONS

This section provides a detailed description of each signal. The signals (Figure 3) are arranged in functional groups according to their associated interface.

The '#' symbol at the end of a signal name indicates that the active, or asserted state occurs when the signal is at a low voltage level. When '#' is not present after the signal name, the signal is asserted when at the high voltage level.

The terms assertion and negation are used extensively. This is done to avoid confusion when working with a mixture of 'active-low' and 'active-high' signals. The term **assert**, or **assertion** indicates that a signal is active, independent of whether that level is represented by a high or low voltage. The term **negate**, or **negation** indicates that a signal is inactive.

2

The following notations are used to describe the signal type.

- in** Input is a standard input-only signal.
- out** Totem Pole output is a standard active driver.
- t/s** Tri-State is a bi-directional, tri-state input/output pin.

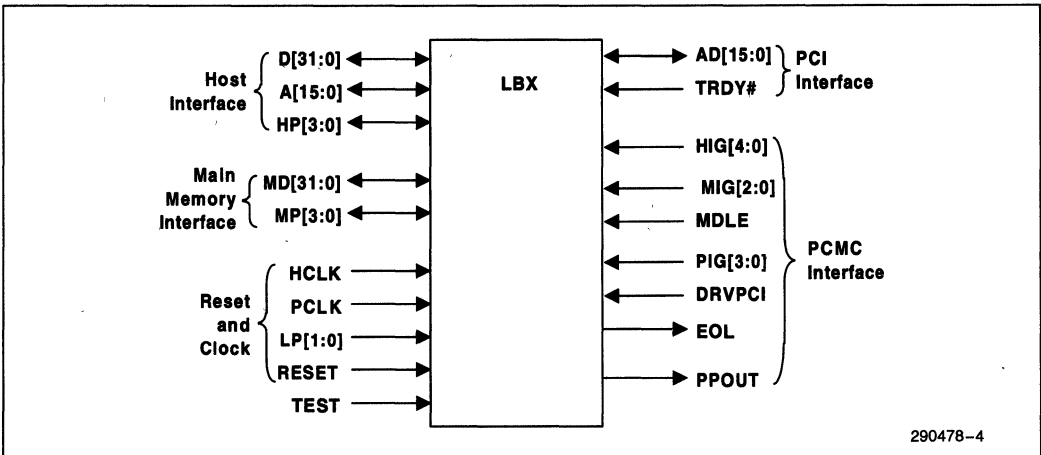

Figure 3. LBX Signals

290478-4



## 2.1 Host Interface Signals

Signal	Type	Description
A[15:0]	t/s	<p><b>ADDRESS BUS:</b> The bi-directional A[15:0] lines are connected to the address lines of the host bus. The high order LBX (determined at reset time using the EOL signal) is connected to A[31:16], and the low order LBX is connected to A[15:0]. The host address bus is common with the Pentium processor, second level cache, PCMC and the two LBXs. During CPU cycles A[31:3] are driven by the CPU and A[2:0] are driven by the PCMC, all are inputs to the LBXs. During inquire cycles the LBX drives the PCI master address onto the host address lines A[31:0]. This snoop address is driven to the CPU and the PCMC by the LBXs to snoop L1 and the integrated second level tags, respectively. During PCI configuration cycles bound for the PCMC, the LBXs will send or receive the configuration data to/from the PCMC by copying the host data bus to/from the host address bus. The LBX drives both halves of the Qword host data bus with data from the 32-bit address during PCMC configuration read cycles. The LBX drives the 32-bit address with either the low Dword or the high Dword during PCMC configuration write cycles.</p> <p>In the 82433NX, these pins contain weak internal pull-down resistors.</p> <p>The high order 82433NX LBX samples A11 at the falling edge of reset to configure the LBX for PLL test mode. When A11 is sampled low, the LBX is in normal operating mode. When A11 is sampled high, the LBX drives the internal HCLK from the PLL on the EOL pin. Note that A11 on the high order LBX is connected to the A27 line on the CPU address bus. This same address line is used to put the PCMC into PLL test mode.</p>
D[31:0]	t/s	<p><b>HOST DATA:</b> The bi-directional D[31:0] lines are connected to the data lines of the host data bus. The high order LBX (determined at reset time using the EOL signal) is connected to the host data bus D[63:48] and D[31:16] lines, and the low order LBX is connected to the host data bus D[47:32] and D[15:0] lines. In the 82433LX, these pins contain weak internal pull-up resistors.</p> <p>In the 82433NX, these pins contain weak internal pull-down resistors.</p>
HP[3:0]	t/s	<p><b>HOST DATA PARITY:</b> HP[3:0] are the bi-directional byte parity signals for the host data bus. The low order parity bit HP[0] corresponds to D[7:0] while the high order parity bit HP[3] corresponds to D[31:24]. The HP[3:0] signals function as parity inputs during write cycles and as parity outputs during read cycles. Even parity is supported and the HP[3:0] signals follow the same timings as D[31:0]. In the 82433LX, these pins contain weak internal pull-up resistors.</p> <p>In the 82433NX, these pins contain weak internal pull-down resistors.</p>

## 2.2 Main Memory (Dram) Interface Signals

Signal	Type	Description
MD[31:0]	t/s	<b>MEMORY DATA BUS:</b> MD[31:0] are the bi-directional data lines for the memory data bus. The high order LBX (determined at reset time using the EOL signal) is connected to the memory data bus MD[63:48] and MD[31:16] lines, and the low order LBX is connected to the memory data bus MD[47:32] and MD[15:0] lines. The MD[31:0] signals drive data destined for either the host data bus or the PCI bus. The MD[31:0] signals input data that originated from either the host data bus or the PCI bus. These pins contain weak internal pull-up resistors.
MP[3:0]	t/s	<b>MEMORY PARITY:</b> MP[3:0] are the bi-directional byte enable parity signals for the memory data bus. The low order parity bit MP[0] corresponds to MD[7:0] while the high order parity bit MP[3] corresponds to MD[31:24]. The MP[3:0] signals are parity outputs during write cycles to memory and parity inputs during read cycles from memory. Even parity is supported and the MP[3:0] signals follow the same timings as MD[31:0]. These pins contain weak internal pull-up resistors.

2

## 2.3 PCI Interface Signals

Signal	Type	Description
AD[15:0]	t/s	<b>ADDRESS AND DATA:</b> AD[15:0] are bi-directional data lines for the PCI bus. The AD[15:0] signals sample or drive the address and data on the PCI bus. The high order LBX (determined at reset time using the EOL signal) is connected to the PCI bus AD[31:16] lines, and the low order LBX is connected to the PCI AD[15:0] lines.
TRDY #	in	<b>TARGET READY:</b> TRDY # indicates the selected (targeted) device's ability to complete the current data phase of the bus operation. For normal operation, TRDY # is tied asserted low. When the TRDY # option is enabled in the PCMC (for zero wait-state PCI burst writes), TRDY # should be connected to the PCI bus.

## 2.4 PCMC Interface Signals

Signal	Type	Description
HIG[4:0]	in	<b>HOST INTERFACE GROUP:</b> These signals are driven from the PCMC and control the host interface of the LBX. The 82433LX decodes the binary pattern of these lines to perform 29 unique functions (30 for the 83433NX). These signals are synchronous to the rising edge of HCLK.
MIG[2:0]	in	<b>MEMORY INTERFACE GROUP:</b> These signals are driven from the PCMC and control the memory interface of the LBX. The LBX decodes the binary pattern of these lines to perform 7 unique functions. These signals are synchronous to the rising edge of HCLK.
PIG[3:0]	in	<b>PCI INTERFACE GROUP:</b> These signals are driven from the PCMC and control the PCI interface of the LBX. The LBX decodes the binary pattern of these lines to perform 15 unique functions. These signals are synchronous to the rising edge of HCLK.
MDLE	in	<b>MEMORY DATA LATCH ENABLE:</b> During CPU reads from DRAM, the LBX uses a clocked register to transfer data from the MD[31:0] and MP[3:0] lines to the D[31:0] and HP[3:0] lines. MDLE is the clock enable for this register. Data is clocked into this register when MDLE is asserted. The register retains its current value when MDLE is negated.  During CPU reads from main memory, the LBX tri-states the D[31:0] and HP[3:0] lines on the rising edge of MDLE when HIG[4:0] = NOPC.
DRVPCI	in	<b>DRIVE PCI BUS:</b> This signals enables the LBX to drive either address or data information onto the PCI AD[15:0] lines.

## 2.4 PCMC Interface Signals (Continued)

Signal	Type	Description
EOL	t/s	<b>End Of Line:</b> This signal is asserted when a PCI master read or write transaction is about to overrun a cache line boundary. The low order LBX will have this pin connected to the PCMC (internally pulled up in the PCMC). The high order LBX connects this pin to a pull-down resistor. With one LBX EOL line being pulled down and the other LBX EOL pulled up, the LBX samples the value of this pin on the negation of the RESET signal to determine if it's the high or low order LBX.
PPOUT	t/s	<p><b>LBX PARITY:</b> This signal reflects the parity of the 16 AD lines driven from or latched into the LBX, depending on the command driven on PIG[3:0]. The PCMC uses PPOUT from both LBXs (called PPOUT[1:0]) to calculate the PCI parity signal (PAR) for CPU to PCI transactions during the address phase of the PCI cycle. The LBX uses PPOUT to check the PAR signal for PCI master transactions to memory during the address phase of the PCI cycle. When transmitting data to PCI the PCMC uses PPOUT to calculate the proper value for PAR. When receiving data from PCI the PCMC uses PPOUT to check the value received on PAR.</p> <p>If the L2 cache does not implement parity, the LBX will calculate parity so the PCMC can drive the correct value on PAR during L2 reads initiated by a PCI master. The LBX samples the PPOUT signal at the negation of reset and compares that state with the state of EOL to determine whether the L2 cache implements parity. The PCMC internally pulls down PPOUT[0] and internally pulls up PPOUT[1]. The L2 supports parity if PPOUT[0] is connected to the high order LBX and PPOUT[1] is connected to the low order LBX. The L2 is defined to not support parity if these connections are reversed, and for this case, the LBX will calculate parity. For normal operations either connection allows proper parity to be driven to the PCMC.</p>

## 2.5 Reset and Clock Signals

Signal	Type	Description
HCLK	in	<b>HOST CLOCK:</b> HCLK is input to the LBX to synchronize command and data from the host and memory interfaces. This input is derived from a buffered copy of the PCMC HCLKx output.
PCLK	in	<b>PCI CLOCK:</b> All timing on the LBX PCI interface is referenced to the PCLK input. All output signals on the PCI interface are driven from PCLK rising edges and all input signals on the PCI interface are sampled on PCLK rising edges. This input is derived from a buffered copy of the PCMC PCLK output.
RESET	in	<b>RESET:</b> Assertion of this signal resets the LBX. After RESET has been negated the LBX configures itself by sampling the EOL and PPOUT pins. RESET is driven by the PCMC CPURST pin. The RESET signal is synchronous to HCLK and must be driven directly by the PCMC.
LP1	out	<b>LOOP 1:</b> Phase Lock Loop Filter pin. The filter components required for the LBX are connected to these pins.
LP2	in	<b>LOOP 2:</b> Phase Lock Loop Filter pin. The filter components required for the LBX are connected to these pins.
TEST	in	<b>TEST:</b> The TEST pin must be tied low for normal system operation.
TSCON	in	<b>TRI-STATE CONTROL:</b> This signal enables the output buffers on the LBX. This pin must be held high for normal operation. If TSCON is negated, all LBX outputs will tri-state.

## 3.0 FUNCTIONAL DESCRIPTION

### 3.1 LBX Post and Prefetch Buffers

This section describes the five write posting and read prefetching buffers implemented in the LBX. The discussion in this section refers to the operation of both LBXs in the system.

#### 3.1.1 CPU-TO-MEMORY POSTED WRITE BUFFER

The write buffer is a queue 4 Qwords deep, it loads Qwords from the CPU and stores Qwords to memory. It is 4 Qwords deep to accommodate write-backs from the first or second level cache. It is organized as a simple FIFO. Commands driven on the HIG[4:0] lines store Qwords into the buffer, while commands on the MIG[2:0] lines retire Qwords from the buffer. While retiring Qwords to memory, the DRAM controller unit of the PCMC will assert the appropriate MA, CAS[7:0]#, and WE# signals. The PCMC keeps track of full/empty states, status of the data and address.

Byte parity for data to be written to memory is either propagated from the host bus or generated by the LBX. The LBX generates parity for data from the second level cache when the second level cache does not implement parity.

#### 3.1.2 PCI-TO-MEMORY POSTED WRITE BUFFER

The buffer is organized as 2 buffers (4 Dwords each). There is an address storage register for each buffer. When an address is stored one of the two buffers is allocated and subsequent Dwords of data are stored beginning at the first location in that buffer. Buffers are retired to memory strictly in order, Qword at a time.

Commands driven on the PIG[3:0] lines post addresses and data into the buffer. Commands driven on HIG[4:0] result in addresses being driven on the host address bus. Commands driven on MIG[2:0] result in data being retired to DRAM.

For cases where the address targeted by the first Dword is odd, i.e. A[2] = 1, and the data is stored in an even location in the buffer, the LBX correctly aligns the Dword when retiring the data to DRAM. In other words the buffer is capable of retiring a Qword to memory where the data in the buffer is shifted by

1 Dword (Dword is position 0 shifted to 1, 1 shifted to 2 etc.). The DRAM controller of the PCMC asserts the correct CAS[7:0]# signals depending on the PCI C/BE[3:0]# signals stored in the PCMC for that Dword.

The End Of Line (EOL) signal is used to prevent PCI master writes from bursting past the cache line boundary. The device that provides "warning" to the PCMC is the low order LBX. This device contains the PCI master write low order address bits necessary to determine how many Dwords are left to the end of the line. Consequently, the LBX protocol uses the EOL signal from the low order LBX to provide this "end-of-line" warning to the PCMC, so that it may retry a PCI master write when it bursts past the cache line boundary. This protocol is described fully in Section 3.3.6.

The LBX calculates Dword parity on PCI write data, sending the proper value to the PCMC on PPOUT. The LBX generates byte parity on the MP signals for writing into DRAM.

#### 3.1.3 PCI-TO-MEMORY READ PREFETCH BUFFER

This buffer is organized as a line buffer (4 Qwords) for burst transfers to PCI. The data is transferred into the buffer a Qword at a time and read out a Dword at a time. The LBX then effectively decouples the memory read rate from the PCI rate to increase concurrence.

Each new transaction begins by storing the first Dword in the first location in the buffer. The starting Dword for reading data out of the buffer onto PCI must be specified within a Qword boundary; that is the first requested Dword on PCI could be an even or odd Dword. If the snoop for a PCI master read results in a write-back from first or second level caches, this write back is sent directly to PCI and main memory. The following two paragraphs describe this process for cache line write-backs.

Since the write-back data from L1 is in linear order, writing into the buffer is straightforward. Only those Qwords to be transferred into PCI are latched into the PCI-to-memory read buffer. For example, if the address targeted by PCI is in the 3rd or 4th Qword in the line, the first 2 Qwords of write back data are discarded and not written into the read buffer. The primary cache write-back must always be written

completely to the CPU-to-Memory posted Write Buffer.

If the PCI master read data is read from the secondary cache, it is not written back to memory. Write-backs from the second level cache, when using burst SRAMs, are in Pentium processor burst order (the order depending on which Qword of the line is targeted by the PCI read). The buffer is directly addressed when latching second level cache write-back data to accommodate this burst order. For example, if the requested Qword is Qword 1, then the burst order is 1-0-3-2. Qword 1 is latched in buffer location 0, Qword 0 is discarded, Qword 3 is latched into buffer location 2 and Qword 2 is latched into buffer location 1.

Commands driven on MIG[2:0] and HIG[4:0] enter data into the buffer from the DRAM interface and the host interface (i.e. the caches), respectively. Commands driven on the PIG[3:0] lines drive data from the buffer onto the PCI AD[31:0] lines.

Parity driven on the PPOUT signal is calculated from the byte parity received on the host bus or the memory bus, whichever is the source. If the second level cache is the source of the data and does not implement parity, the parity driven on PPOUT is generated by the LBX from the second level cache data. If main memory is the source of the read data, PCI parity is calculated from the DRAM byte parity. Main memory must implement byte parity to guarantee correct PCI parity generation.

### 3.1.4 CPU-TO-PCI POSTED WRITE BUFFER

The CPU-to-PCI Posted Write Buffer is 4 Dwords deep. The buffer is constructed as a simple FIFO,

with some performance enhancements. An address is stored in the LBX with each Dword of data. The structure of the buffer accommodates the packetization of writes to be burst on PCI. This is accomplished by effectively discarding addresses of data Dwords driven within a burst. Thus, while an address is stored for each Dword, an address is not necessarily driven on PCI for each Dword. The PCMC determines when a burst write may be performed based on consecutive addresses. The buffer also enables consecutive bytes to be merged within a single Dword, accommodating byte, word, and misaligned Dword string store and string move operations. Qword writes on the host bus are stored within the buffer as two individual Dword writes, with separate addresses.

The storing of an address with each Dword of data allows burst writes to be retried easily. In order to retry transactions, the FIFO is effectively "backed up" by one Dword. This is accomplished by making the FIFO physically one entry larger than it is logically. Thus, the buffer is physically 5 entries deep (an entry consists of an address and a Dword of data), while logically it is considered full when 4 entries have been posted. This design allows the FIFO to be backed up one entry when it is logically full.

Commands driven on HIG[4:0] post addresses and data into the buffer, and commands driven on PIG[3:0] retire addresses and data from the buffer and drive them onto the PCI AD[31:0] lines. As discussed previously, when bursting, not all addresses are driven onto PCI.

Data parity driven on the PPOUT signal is calculated from the byte parity received on the host bus. Address parity driven on PPOUT is calculated from the address received on the host bus.

### 3.1.5 CPU-TO-PCI READ PREFETCH BUFFER

This prefetch buffer is organized as a single buffer 4 Dwords deep. The buffer is organized as a simple FIFO. reads from the buffer are sequential; the buffer does not support random access of its contents. To support reads of less than a Dword the FIFO read pointer can function with or without a pre-increment. The pointer can also be reset to the first entry before a Dword is driven. When a Dword is read, it is driven onto both halves of the host data bus.

Commands driven on the HIG[4:0] lines enable read addresses to be sent onto PCI, the addresses are driven using PIG[3:0] commands. Read data is latched into the LBX by commands driven on the PIG[3:0] lines and the data is driven onto the host data bus using commands driven on the HIG[4:0] lines.

The LBX calculates Dword parity on PCI read data, sending the proper value to the PCMC on PPOUT. The LBX does not generate byte parity on the host data bus when the CPU reads PCI.

## 3.2 LBX Interface Command Descriptions

This section describes the functionality of the HIG, MIG and PIG commands driven by the PCMC to the LBXs.

### 3.2.1 HOST INTERFACE GROUP: HIG[4:0]

The Host Interface commands are shown in Table 1. These commands are issued by the host interface of the PCMC to the LBXs in order to perform the following functions:

- Reads from CPU-to-PCI read prefetch buffer when the CPU reads from PCI.
- Stores write-back data to PCI-to-memory read prefetch buffer when PCI read address results in a hit to a modified line in first or second level caches.
- Posts data to CPU-to-memory write buffer in the case of a CPU to memory write.
- Posts data to CPU-to-PCI write buffer in the case of a CPU to PCI write.
- Drives host address to Data lines and data to address lines for programming the PCMC configuration registers.

2

Table 1. HIG Commands

Command	Code	Description
NOPC	00000b	No Operation on CPU Bus
CMR	11100b	CPU Memory Read
CPRF	00100b	CPU Read First Dword from CPU-to-PCI Read Prefetch Buffer
CPRA	00101b	CPU Read Next Dword from CPU-to-PCI Read Prefetch Buffer, Toggle A
CPRB	00110b	CPU Read Next Dword from CPU-to-PCI Read Prefetch Buffer, Toggle B
CPRQ	00111b	CPU Read Qword from CPU-to-PCI Read Prefetch Buffer
SWB0	01000b	Store Write-Back Data Qword 0 to PCI-to-Memory Read Buffer
SWB1	01001b	Store Write-Back Data Qword 1 to PCI-to-Memory Read Buffer
SWB2	01010b	Store Write-Back Data Qword 2 to PCI-to-Memory Read Buffer
SWB3	01011b	Store Write-Back Data Qword 3 to PCI-to-Memory Read Buffer
PCMWQ	01100b	Post to CPU-to-Memory Write Buffer Qword
PCMWFQ	01101b	Post to CPU-to-Memory Write and PCI-to-Memory Read Buffer First Qword
PCMWNQ	01110b	Post to CPU-to-Memory Write and PCI-to-Memory Read Buffer Next Qword
PCPWL	10000b	Post to CPU-to-PCI Write Low Dword
MCP3L	10011b	Merge to CPU-to-PCI Write Low Dword 3 Bytes
MCP2L	10010b	Merge to CPU-to-PCI Write Low Dword 2 Bytes
MCP1L	10001b	Merge to CPU-to-PCI Write Low Dword 1 Byte
PCPWH	10100b	Post to CPU-to-PCI Write High Dword
MCP3H	10111b	Merge to CPU-to-PCI Write High Dword 3 Bytes
MCP2H	10110b	Merge to CPU-to-PCI Write High Dword 2 Bytes
MCP1H	10101b	Merge to CPU-to-PCI Write High Dword 1 Byte
LCPRAD	00001b	Latch CPU-to-PCI Read Address
DPRA	11000b	Drive Address from PCI A/D Latch to CPU Address Bus
DPWA	11001b	Drive Address from PCI-to-Memory Write Buffer to CPU Address Bus
ADCPY	11101b	Address to Data Copy in the LBX
DACPYH	11011b	Data to Address Copy in the LBX High Dword
DACPYL	11010b	Data to Address Copy in the LBX Low Dword
PSCD	01111b	Post Special Cycle Data
DRVFF	11110b	Drive FF..FF (All 1's) onto the Host Data Bus
PCPWHC	00011b	Post to CPU-to-PCI Write High Dword Configuration

**NOTE:**

All other patterns are reserved.

<b>NOPC</b>	No Operation is performed on the host bus by the LBX hence it tri-states its host bus drivers.	<b>SWB0</b>	This command stores a Qword from the host data lines into location 0 of the PCI-to-Memory Read Buffer. Parity is either generated for the data or propagated from the host bus based on the state of the PPOUT signals sampled at the negation of RESET when the LBXs were initialized.
<b>CMR</b>	This command effectively drives DRAM data onto the host data bus. The LBX acts as a transparent latch in this mode, depending on MDLE for latch control. With the MDLE signal high the CMR command will cause the LBXs to buffer memory data onto the host bus. When MDLE is low. The LBX will drive onto the host bus whatever memory data that was latched when MDLE was negated.	<b>SWB1</b>	This command, (similar to SWB0), stores a Qword from the host data lines into location 1 of the PCI-to-Memory Read Buffer. Parity is either generated from the data or propagated from the host bus based on the state of the PPOUT signal sampled at the falling edge of RESET.
<b>CPRF</b>	This command reads the first Dword of the CPU-to-PCI read prefetch buffer. The read pointer of the FIFO is set to point to the first Dword. The Dword is driven onto the high and low halves of the host data bus.	<b>SWB2</b>	This command, (similar to SWB0), stores a Qword written back from the first or second level cache into location 2 of the PCI-to-memory read buffer. Parity is either generated from the data or propagated from the host bus based on the state of the PPOUT signal sampled at the falling edge of RESET.
<b>CPRA</b>	This command increments the read pointer of the CPU-to-PCI read prefetch buffer FIFO and drives that Dword onto the host bus when it is driven after a CPRF or CPRB command. If driven after another CPRA command, the LBX drives the current Dword while the read pointer of the FIFO is not incremented. The Dword is driven onto the upper and lower halves of the host data bus.	<b>SWB3</b>	This command stores a Qword from the host data lines into location 3 of the PCI-to-Memory Read Buffer. Parity is either generated for the data or propagated from the host bus based on the state of the PPOUT signal sampled at the falling edge of RESET.
<b>CPRB</b>	This command increments the read pointer of the CPU-to-PCI read prefetch buffer FIFO and drives that Dword onto the host bus when it is driven after a CPRA command. If driven after another CPRB command, the LBX drives the current Dword while the read pointer of the FIFO is not incremented. The Dword is driven onto the upper and lower halves of the host data bus.	<b>PCMWQ</b>	This command posts one Qword of data from the host data lines to CPU-to-Memory Write Buffer in case of a CPU memory write or a write-back from the second level cache.
<b>CPRQ</b>	This command drives the first Dword stored in the CPU-to-PCI read prefetch buffer onto the lower half of the host data bus, and drives the second Dword onto the upper half of the host data bus, regardless of the state of the read pointer. The read pointer is not affected by this command.	<b>PCMWFQ</b>	If the PCI Memory read address leads to a hit on a modified line in the first level cache, then a write-back is scheduled and this data has to be written into the CPU-to-Memory Write Buffer and PCI-to-Memory Read Buffer at the same time. The write-back of the first Qword is done by this command to both the buffers.
		<b>PCMWNQ</b>	This command follows the previous command to store or post subsequent write-back Qwords.

2



- PCPWL** This command posts the low Dword of a CPU-to-PCI write. The CPU-to-PCI Write Buffer stores a Dword of PCI address for every Dword of data. Hence, this command also stores the address of the Low Dword in the address location for the data. Address bit 2 (A2) is not stored directly. This command assumes a value of 0 for A2 and this is what is stored.
- MCP3L** This command merges the 3 most significant bytes of the low Dword of the host data bus into the last Dword posted to the CPU-to-PCI write buffer. The address is not modified.
- MCP2L** This command merges the 2 most significant bytes of the low Dword of the host data bus into the last Dword posted to the CPU-to-PCI write buffer. The address is not modified.
- MCP1L** This command merges the most significant byte of the low Dword of the host data bus into the last Dword posted to the CPU-to-PCI write buffer. The address is not modified.
- PCPWH** This command posts the upper Dword of a CPU-to-PCI write, with its address, into the address location. Hence, to do a Qword write PCPWL has to be followed by a PCPWH. Address bit 2 (A2) is not stored directly. This command forces a value of 1 for A2 and this is what is stored.
- MCP3H** This command merges the 3 most significant bytes of the high Dword of the host data bus into the last Dword posted to the CPU-to-PCI Write Buffer. The address is not modified.
- MCP2H** This command merges the 2 most significant bytes of the high Dword of the host data bus into the last Dword posted to the CPU-to-PCI Write Buffer. The address is not modified.
- MCP1H** This command merges the most significant byte of the high Dword of the host data bus into the last Dword posted to the CPU-to-PCI Write Buffer. The address is not modified.
- LCPRAD** This command latches the host address to drive on PCI for a CPU-to-PCI read. It is necessary to latch the address in order to drive inquire addresses on the host address bus before the CPU address is driven onto PCI.
- DPRA** The PCI memory read address is latched in the PCI A/D latch by a PIG command LCPRAD, this address is driven onto the host address bus by DPRA. Used in PCI to memory read transaction.
- DPWA** The DPWA command drives the address of the current PCI Master Write Buffer onto the host address bus. This command is potentially driven for multiple cycles. When it is no longer driven, the read pointer will increment to point to the next buffer, and a subsequent DPWA command will read the address from that buffer.
- ADCPY** This command drives the host data bus with the host address. The address is copied on the high and low halves of the Qword data bus; i.e. A[31:0] is copied onto D[31:0] and D[63:32]. This command is used when the CPU writes to the PCMC configuration registers.
- DACPYH** This command drives the host address bus with the high Dword of host data. This command is used when the CPU writes to the PCMC configuration registers.
- DACPYL** This command drives the host address bus with the low Dword of host data. This command is used when the CPU writes to the PCMC configuration registers.
- PSCD** This command is used to post the value of the Special Cycle code into the CPU-to-PCI Posted Write Buffer. The value is driven onto the A[31:0] lines by the PCMC, after acquiring the address bus by asserting AHOLD. The value on the A[31:0] lines is posted into the DATA location in the CPU-to-PCI Posted Write Buffer.
- DRVFF** This command causes the LBX to drive all "1s" (i.e. FFFFFFFh) onto the host data bus. It is used for CPU reads from PCI that terminate with master abort.
- PCPWNC** This command posts the high half of the CPU data bus. The LBXs post the high half of the data bus even if A2 from the PCMC is low. This command is used during configuration writes when using PCI configuration access mechanism #1.

**3.2.2 MEMORY INTERFACE GROUP: MIG[2:0]**

The Memory Interface commands are shown in Table 2. These commands are issued by the DRAM controller of the PCMC to perform the following functions:

- Retires data from CPU-to-Memory Write Buffer to DRAM.
- Stores data into PCI-to-Memory Read Buffer when the PCI read address is targeted to DRAM.
- Retires PCI-to-Memory Write Buffer to DRAM.

**Table 2. MIG Commands**

Command	Code	Description
NOPM	000b	No Operation on Memory Bus
PMRFQ	001b	Place into PCI-to-Memory Read Buffer First Qword
PMRNQ	010b	Place into PCI-to-Memory Read Buffer Next Qword
RCMWQ	100b	Retire CPU-to-Memory Write Buffer Qword
RPMWQ	101b	Retire PCI-to-Memory Write Buffer Qword
RPMWQS	110b	Retire PCI-to-Memory Write Buffer Qword Shifted
MEMDRV	111b	Drive Latched Data Onto Memory Bus for 1 Clock Cycle

2

**NOTE:**

All other patterns are reserved.

**NOPMN** Operation on the memory bus. The LBX tri-states its drivers driving the memory bus.

**PMRFQ** The PCI-to-Memory read address targets memory if there is a miss on first and second caches. This command stores the first Qword of data starting at the first location in the buffer. This buffer is 8 Dwords or 1 cache line deep.

**PMRNQ** This command stores subsequent Qwords from memory starting at the next available location in the PCI-to-Memory Read Buffer. It is always used after PMRFQ.

**RCMWQ** This command retires one Qword from the CPU-to-Memory Write Buffer to DRAM. The address is stored in the address queue for this buffer in the PCMC.

**RPMWQ** This command retires one Qword of data from one line of the PCI-to-Memory write buffer to DRAM. When all the valid data in one buffer is retired, the next RPMWQ (or RPMWQS) will read data from the next buffer.

**RPMWQS** This command retires one Qword of data from one line of PCI-to-Memory write buffer to DRAM. For this command the data in the buffer is shifted by one Dword (Dword in position 0 is shifted to 1, 1 to 2 etc.). This is because the address targeted by the first Dword of the write could be an odd Dword (i.e., address bit[2] is a 1). To retire a misaligned line this command has to be used for all the data in the buffer. When all the valid data in one buffer is retired, the next RPMWQ (or RPMWQS) will read data from the next buffer.

**MEMDRV** For a memory write operation the data on the memory bus is required for more than one clock cycle hence all DRAM retires are latched and driven to the memory bus in subsequent cycles by this command.

### 3.2.3 PCI INTERFACE GROUP: PIG[3:0]

The PCI Interface commands are shown in Table 3. These commands are issued by the PCI master/slave interface of the PCMC to perform the following functions:

- Slave posts address and data to PCI-to-Memory Write Buffer.
- Slave sends PCI-to-Memory read data on the AD bus.
- Slave latches PCI master memory address so that it can be gated to the host address bus.
- Master latches CPU-to-PCI read data from the AD bus.
- Master retires CPU-to-PCI write buffer.
- Master sends CPU-to-PCI address to the AD bus.

The PCI AD[31:0] lines are driven by asserting the signal DRVPCI. This signal is used for both master and slave transactions.

Parity is calculated on either the value being driven onto PCI or the value being received on PCI, depending on the command. In Table 3, the PAR column has been included to indicate the value that the PPOUT signals are based on. An "I" indicates that the PPOUT signals reflect the parity of the AD lines as inputs to the LBX. An "O" indicates that the PPOUT signals reflect the value being driven on the PCI AD lines. See Section 3.3.4 for the timing relationship between the PIG[3:0] command, the AD[31:0] lines, and the PPOUT signals.

**Table 3. PIG Commands**

Command	Code	PAR	Description
PPMWA	1000b	I	Post to PCI-to-Memory Write Buffer Address
PPMWD	1001b	I	Post to PCI-to-Memory Write Buffer Data
SPMRH	1101b	O	Send PCI Master Read Data High Dword
SPMRL	1100b	O	Send PCI Master Read Data Low Dword
SPMRN	1110b	O	Send PCI Master Read Data Next Dword
LCPRF	0000b	I	Latch CPU Read from PCI into Read Prefetch Buffer First Dword
LCPRA	0001b	I	Latch CPU Read from PCI into Prefetch Buffer Next Dword, A Toggle
LCPRB	0010b	I	Latch CPU Read from PCI into Prefetch Buffer Next Dword, B Toggle
DCPWA	0100b	O	Drive CPU-to-PCI Write Buffer Address
DCPWD	0101b	O	Drive CPU-to-PCI Write Buffer Data
DCPWL	0110b	O	Drive CPU-to-PCI Write Buffer Last Data
DCCPD	1011b	O	Discard Current CPU-to-PCI Write Buffer Data
BCPWR	1010b	O	Backup CPU-to-PCI Write Buffer for Retry
SCPA	0111b	O	Send CPU-to-PCI Address
LPMA	0011b	I	Latch PCI Master Address

**NOTE:**

All other patterns are reserved.

<b>PPMWA</b>	This command selects a new buffer and places the PCI master address latch value into the address register for that buffer. The next PPMWD command posts write data in the first location of this newly selected buffer. This command also causes the EOL logic to decrement the count of Dwords remaining in the line.	<b>LCPRB</b>	When driven after a LCPRA command, this command latches the value of the AD[31:0] lines into the next location into the CPU-to-PCI Read Prefetch Buffer. When driven after another LCPRB command, this command latches the value on AD[31:0] into the same location in the CPU-to-PCI Read Prefetch Buffer, overwriting the previous value.
<b>PPMWD</b>	This command stores the value in the AD latch into the next data location in the currently selected buffer. This command also causes the EOL logic to decrement the count of Dwords remaining in the line.	<b>DCPWA</b>	This command drives the next address in the CPU-to-PCI Write Buffer onto PCI. The read pointer of the FIFO is not incremented.
<b>SPMRH</b>	This command sends the high order Dword from the first Qword of the PCI-to-Memory Read Buffer onto PCI. This command also causes the EOL logic to decrement the count of Dwords remaining in the line.	<b>DCPWD</b>	This command drives the next data Dword in the CPU-to-PCI Write Buffer onto PCI. This is the data of the FIFO is incremented on the next PCLK if TRDY # is asserted.
<b>SPMRL</b>	This command sends the low order Dword from the first Qword of the PCI-to-Memory Read Buffer onto PCI. This command also selects the Dword alignment for the transaction and causes the EOL logic to decrement the count of Dwords remaining in the line.	<b>DCPWL</b>	This command drives the previous data Dword in the CPU-to-PCI Write Buffer onto PCI. This is the data which was driven by the last DCPWD command. The read pointer of the FIFO is not incremented.
<b>SPMRN</b>	This command sends the next Dword from the PCI-to-Memory Read Buffer onto PCI. This command also causes the EOL logic to decrement the count of Dwords remaining in the line. This command is used for the second and all subsequent Dwords of the current transaction.	<b>DCCPD</b>	This command discards the current Dword in the CPU-to-PCI Write Buffer. This is used to clear write data when the write transaction terminates with master abort, where TRDY # is never asserted.
<b>LCPRF</b>	This command acquires the value of the AD[31:0] lines into the first location in the CPU-to-PCI Read Prefetch Buffer until a different command is driven.	<b>BCPWR</b>	For this command the CPU-to-PCI Write Buffer is "backed up" one entry such that the address/data pair last driven with the DCPWA and DCPWD commands will be driven again on the AD[31:0] lines when the commands are driven again. This command is used when the target has retried the write cycle.
<b>LCPRA</b>	When driven after a LCPRF or LCPRB command, this command latches the value of the AD[31:0] lines into the next location into the CPU-to-PCI Read Prefetch Buffer. When driven after another LCPRA command, this command latches the value on AD[31:0] into the same location in the CPU-to-PCI Read Prefetch Buffer, overwriting the previous value.	<b>SCPA</b>	This command drives the value on the host address bus onto PCI.
		<b>LPMA</b>	This command stores the previous AD[31:0] value into the PCI master address latch. If the EOL logic determines that the requested Dword is the last Dword of a line, then the EOL signal will be asserted; otherwise the EOL signal will be negated.

### 3.3 LBX Timing Diagrams

This section describes the timing relationship between the LBX control signals and the interface buses.

#### 3.3.1 HIG[4:0] COMMAND TIMING

The commands driven on HIG[4:0] can cause the host address bus and/or the host data bus to be driven and latched. The following timing diagram illustrates the timing relationship between the driven command and the buses. The "host bus" in Figure 4 could be address and/or data.

Note that the Drive command takes two cycles to drive the host data bus, but only one to drive the address. When the NOPC command is sampled, the LBX takes only one cycle to release the host bus.

The Drive commands in Figure 4 are any of the following:

<b>CMR</b>	<b>CPRF</b>	<b>CPRA</b>	<b>CPRB</b>
<b>CPRQ</b>	<b>DPRA</b>	<b>DPWA</b>	<b>ADCPY</b>
<b>DACPYH</b>	<b>DACPYL</b>	<b>DRVFF</b>	

The Latch command in Figure 4 is any of the following:

<b>SWB0</b>	<b>SWB1</b>	<b>SWB2</b>	<b>SWB3</b>
<b>PCMWQ</b>	<b>PCMWFQ</b>	<b>PCMWNQ</b>	<b>PCPWL</b>
<b>MCP3L</b>	<b>MCP2L</b>	<b>MCP1L</b>	<b>PCPWH</b>
<b>MCP3H</b>	<b>MCP2H</b>	<b>LCPRAD</b>	<b>PSCD</b>

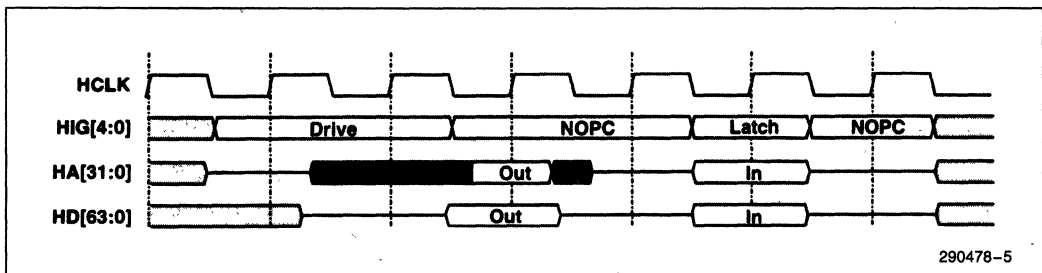

Figure 4. HIG[4:0] Command Timing

**3.3.2 HIG[4:0] MEMORY READ TIMING**

Figure 5 illustrates the timing relationship between the HIG[4:0], MIG[2:0], CAS[7:0]#, and MDLE signals for DRAM memory reads. The delays shown in the diagram do not represent the actual AC timings, but are intended only to show how the delay affects the sequencing of the signals.

When the CPU is reading from DRAM, the HIG[4:0] lines are driven with the CMR command that causes the LBX to drive memory data onto the HD bus. Until the MD bus is valid, the HD bus is driven with invalid data. When CAS[7:0]# assert, the MD bus becomes valid after the DRAM CAS[7:0]# access time. The MD and MP lines are directed through a

synchronous register inside the LBX to the HD and HP lines. MDLE acts as a clock enable for this register. When MDLE is asserted, the LBX samples the MD and MP lines. When MDLE is negated, the MD and HD register retains its current value.

The LBX releases the HD bus based on sampling the NOPC command on the HIG[4:0] lines and MDLE being asserted. By delaying the release of the HD bus until MDLE is asserted, the LBX provides hold time for the data with respect to the write enable strobes (CWE[7:0]#) of the second level cache.

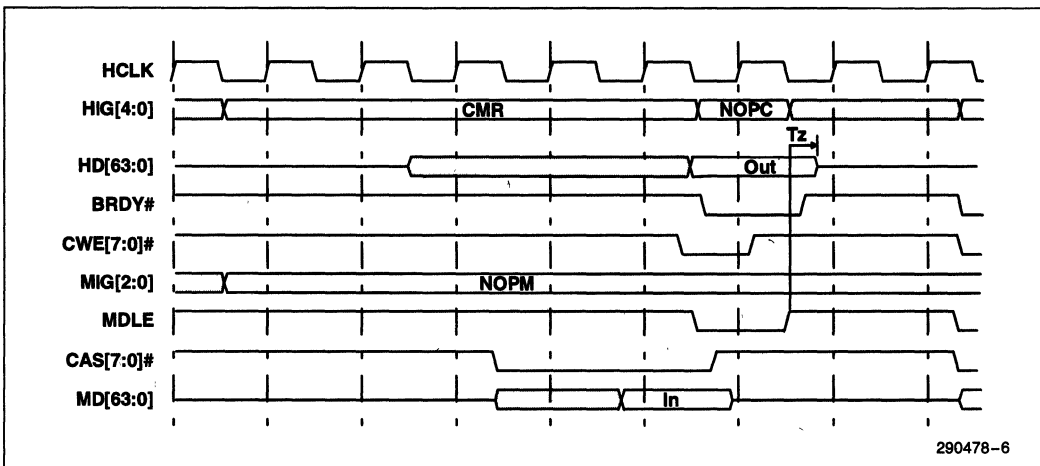

**Figure 5. CPU Read from Memory**

2

290478-6

**3.3.3 MIG[2:0] COMMAND**

Figure 6 illustrates the timing of the MIG[2:0] commands with respect to the MD bus, CAS[7:0] #, and WE#. Figure 6 shows the MD bus transitioning from a read to a write cycle.

The Latch command in Figure 6 is any of the following:

**PMRFQ PMRNQ**

The Retire command in Figure 6 is any of the following:

**RCMWQ RPMWQ RPMWQS**

The data on the MD bus is sampled at the end of the first cycle into the LBX based on sampling the Latch command. The CAS[7:0] # signals can be negated in the next cycle. The WE# signal is asserted in the next cycle. The required delay between the assertion of WE# and the assertion of CAS[7:0] # means that the MD bus has 2 cycles to turn around; hence the NOPM command driven in the second clock. The LBX starts to drive the MD bus based on sampling the Retire command at the end of the third clock. After the Retire command is driven for 1 cycle, the data is held at the output by the MEMDRV command. The LBX releases the MD bus based on sampling the NOPM command at the end of the sixth clock.

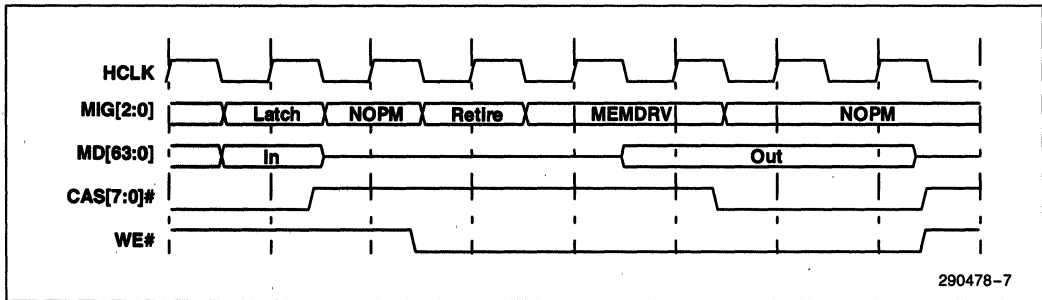

**Figure 6. MIG[2:0] Command Timing**

**3.3.4 PIG[3:0] COMMAND, DRVPCI, AND PPOUT TIMING**

Figure 7 illustrates the timing of the PIG[3:0] commands, the DRVPCI signal, and the PPOUT[1:0] signal relative to the PCI AD[31:0] lines.

The Drive commands in Figure 7 are any of the following:

**SPMRH SPMRL SPMRN  
DCPWA DCPWD DCPWL  
SCPA**

The Latch commands in Figure 7 are any of the following:

**PPMWA PPMWD LPMA**

The following commands do not fit in either category, although they function like Latch type commands with respect to the PPOUT[1:0] signals. They are described in Section 3.3.5.

**LCPRF LCPRA LCPRB**

The DRVPCI signal is driven synchronous to the PCI bus, enabling the LBXs to initiate driving the PCI AD[31:0] lines one clock after DRVPCI is asserted. As shown in Figure 7, if DRVPCI is asserted in cycle N, the PCI AD[31:0] lines are driven in cycle N + 1. The negation of the DRVPCI signal causes the LBXs to asynchronously release the PCI bus, enabling the LBXs to cease driving the PCI AD[31:0] lines in the same clock that DRVPCI is negated. As shown in Figure 7, if DRVPCI is negated in cycle N, the PCI AD[31:0] lines are released in cycle N.

PCI address and data parity is available at the LBX interface on the PPOUT lines from the LBX. The parity for data flow from PCI to LBX is valid 1 clock cycle after data on the AD bus. The parity for data flow from LBX to PCI is valid in the same cycle as the data. When the AD[31:0] lines transition from input to output, there is no conflict on the parity lines due to the dead cycle for bus turnaround. This is illustrated in the sixth and seventh clock of Figure 7.

2

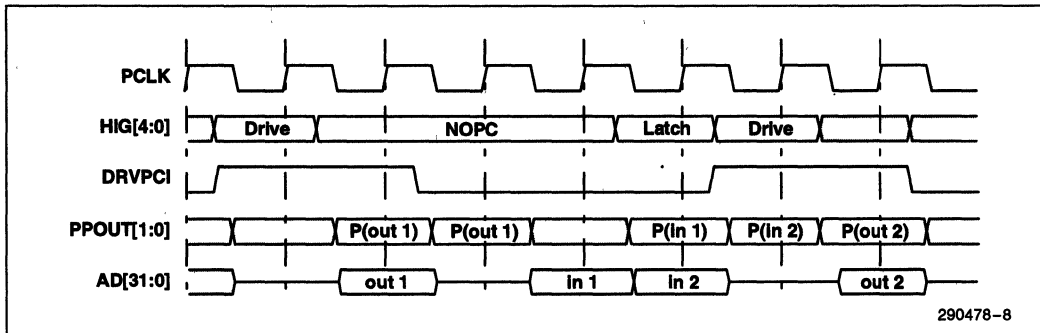

**Figure 7. PIG[3:0] Command Timing**



### 3.3.5 PIG[3:0]: READ PREFETCH BUFFER COMMAND TIMING

The structure of the CPU-to-PCI read prefetch buffer requires special considerations due to the partition of the PCMC and LBX. The PCMC interfaces only to the PCI control signals, while the LBXs interface only to the data. Therefore, it is not possible to latch a Dword of data into the prefetch buffer after it is qualified by TRDY#. Instead, the data is repetitively latched into the same location until TRDY# is sampled asserted. Only after TRDY# is sampled asserted is data valid in the buffer. A toggling mechanism is implemented to advance the write pointer to the next Dword after the current Dword has been qualified by TRDY#.

Other considerations of the partition are taken into account on the host side as well. When reading from the buffer, the command to drive the data onto the host bus is sent before it is known that the entry is valid. This method avoids the wait-state that would be introduced by waiting for an entry's TRDY# to be asserted before sending the command to drive the entry onto the host bus. The FIFO structure of the buffer also necessitates a toggling scheme to advance to the next buffer entry after the current entry has been successfully driven. Also, this method gives the LBX the ability to drive the same Dword twice, enabling reads of less than a Dword to be serviced by the buffer; reads of individual bytes of a Dword would read the same Dword 4 times.

The HIG[4:0] and PIG[3:0] lines are defined to enable the features described previously. The LCPRF PIG[3:0] command latches the first PCI read Dword into the first location in the CPU-to-PCI read prefetch buffer. This command is driven until TRDY# is sampled asserted. The valid Dword would then be in the first location of the buffer. The cycle after TRDY# is sampled asserted, the PCMC drives the LCPRA command on the PIG[3:0] lines. This action latches the value on the PCI AD[31:0] lines into the *next* Dword location in the buffer. Again, the LCPRA command is driven until TRDY# is sampled asserted. Each cycle the LCPRA command is driven, data is latched into the same location in the buffer. When TRDY# is sampled asserted, the PCMC drives the LCPRB command on the PIG[3:0] lines. This latches the value on the AD[31:0] lines into the next location in the buffer, the one *after* the location that the previous LCPRA command latched data into. After TRDY# has been sampled asserted again, the command switches back to LCPRA. In this way, the same location in the buffer can be filled repeatedly until valid, and when it is known that the location is valid, the next location can be filled.

The commands for the HIG[4:0], CPRF, CPRA, and CPRB, work exactly the same way. If the same command is driven, the same data is driven. Driving an appropriately different command results in the next data being driven. Figure 8 illustrates the usage of these commands.

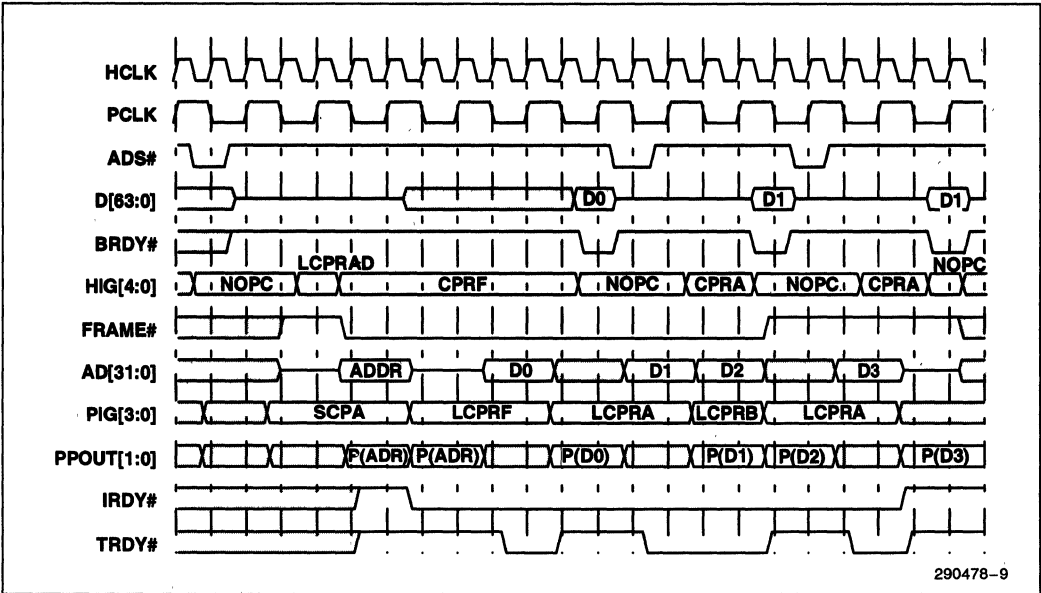

Figure 8. PIG[3:0] CPU-to-PCI Read Prefetch Buffer Commands

Figure 8 shows an example of how the PIG commands function on the PCI side. The LCPRF command is driven on the PIG[3:0] lines until TRDY# is sampled asserted at the end of the fifth PCI clock. The LCPRA command is then driven until TRDY# is again sampled asserted at the end of the seventh PCI clock. TRDY# is sampled asserted again so LCPRB is driven only once. Finally, LCPRA is driven again until the last TRDY# is asserted at the end of the tenth PCI clock. In this way, 4 Dwords are latched in the read CPU-to-PCI prefetch buffer.

Figure 8 also shows an example of how the HIG commands function on the host side of the LBX. Two clocks after sampling the CPRF command, the LBX drives the host data bus. The data takes two cycles to become stable. The first data driven in this case is invalid, since the data has not arrived on PCI. The data driven on the host bus changes in the seventh host clock, since the LCPRF command has been driven on the PIG[3:0] lines the previous cycle,

latching a new value into the first location of the read prefetch buffer. At this point the data is not the correct value, since TRDY# has not yet been asserted on PCI. The LCPRF command is driven again in the fifth PCI clock while TRDY# is sampled asserted at the end of this clock. The requested data for the read is then latched into the first location of the read prefetch buffer and driven onto the host data bus, becoming valid at the end of CPU clock 12. The BRDY# signal can therefore be driven asserted in this clock. The following read transaction (issued in CPU clock 15) requests the next Dword, and so the CPRA command is driven on the HIG[4:0] lines, advancing to read the next location in the read prefetch buffer. As the correct data is already there, the command is driven only once for this transaction. The next read transaction requests data in the same Dword as the previous. Therefore, the CPRA command is driven again, the buffer is not advanced, and the same Dword is driven onto the host bus.

2

290478-9

**3.3.6 PIG[3:0]: END-OF-LINE  
WARNING SIGNALS: EOL**

When posting PCI master writes, the PCMC must be informed when the line boundary is about to be overrun, as it has no way of determining this itself (recall that the PCMC does not receive any address bits from PCI). The low order LBX determines this, as it contains the low order bits of the PCI master write address and also tracks how many Dwords of write data have been posted. Therefore, the low order LBX component sends the "end-of-line" warning to the PCMC. This is accomplished with the EOL signal driven from the low order LBX to the PCMC. Figure 9 illustrates the timing of this signal.

1. The FRAME# signal is sampled asserted in the first cycle. The LPMA command is driven on the PIG[3:0] signals to hold the address while it is being decoded (e.g. in the MEMCS# decode circuit of the 82378 SIO). The first data (D0) remains on the bus until TRDY# is asserted in response to MEMCS# being sampled asserted in the third clock.
2. The PPMWA command is driven in response to sampling MEMCS# asserted. TRDY# is asserted in this cycle indicating that D0 has been latched at the end of the fourth clock. The action of the PPMWA command is to transfer the PCI address

captured in the PCI AD latch at the end of the first clock to the posting buffer, and open the PCI AD latch in order to capture the data. This data will be posted to the write buffer in the following cycle by the PPMWD command.

3. The EOL signal is first negated when the LPMA command is driven on the PIG[3:0] signals. However, if the first data Dword accepted is also the last that should be accepted, the EOL signal will be asserted in the third clock. This is the "end-of-line" indication. In this case, the EOL signal is asserted as soon as the LPMA command has been latched. The action by the PCMC in response is to negate TRDY# and assert STOP# in the fifth clock. Note that the EOL signal is asserted even before the MEMCS# signal is sampled asserted in this case. The EOL signal will remain asserted until the next time the LPMA command is driven.
4. If the second Dword is the last that should be accepted, the EOL signal will be asserted in the fifth clock to negate TRDY# and assert STOP# on the following clock. The EOL signal is asserted in response to the PPMWA command being sampled, and relies on the knowledge that TRDY# for the first Dword of data will be sampled asserted by the master in the same cycle (at the end of the fourth clock). Therefore, to prevent a third assertion of TRDY# in the sixth clock, the EOL signal must be asserted in the fifth clock.

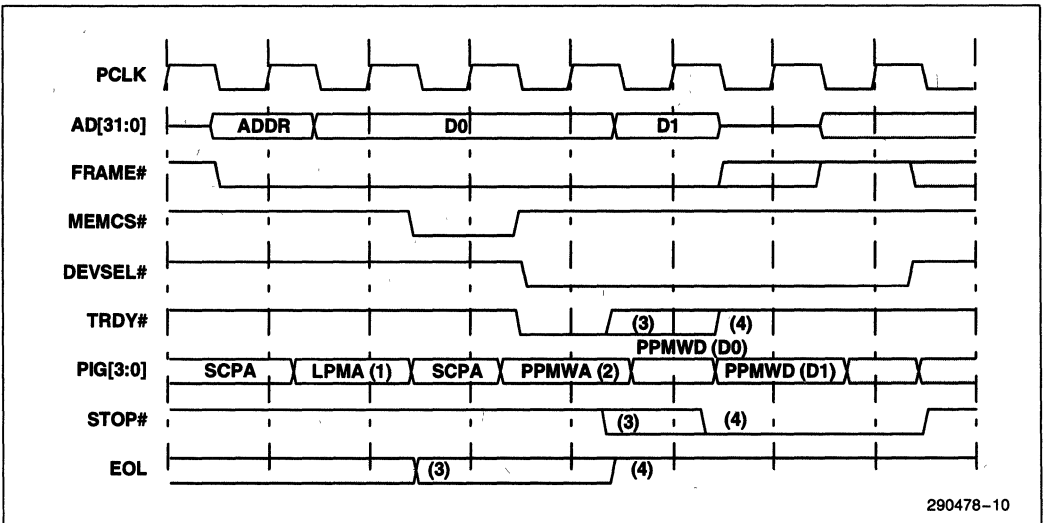

Figure 9. EOL Signal Timing for PCI Master Writes

290478-10

A similar sequence is defined for PCI master reads. While it is possible to know when to stop driving read data due to the fact that the read address is latched into the PCMC before any read data is driven on PCI, the use of the EOL signal for PCI master reads simplifies the logic internal to the PCMC. Figure 10 illustrates the timing of EOL with respect to the PIG[3:0] commands to drive out PCI read data.

Note that unlike the PCI master write sequence, the STOP# signal is asserted with the last data transfer, not after.

1. The LPMA command sampled at the end of the second clock causes the EOL signal to assert if there is only one Dword left in the line, otherwise it will be negated. The first TRDY# will also be the last, and the STOP# signal will be asserted with TRDY#.
2. The SPMRH command causes the count of the number of Dwords left in the line to be decremented. If this count reaches one, the EOL signal is asserted. The next TRDY# will be the last, and STOP# is asserted with TRDY#.

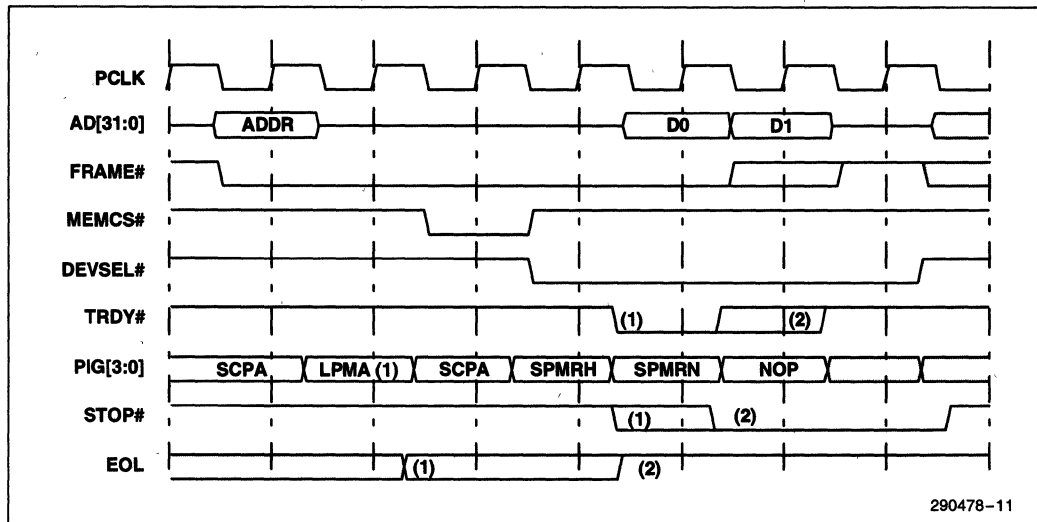

Figure 10. EOL Signal Timing for PCI Master Reads

290478-11

2

### 3.4 PLL Loop Filter Components

As shown in Figure 11, loop filter components are required on the LBX components. A 4.7 K $\Omega$  5% resistor is typically connected between pins LP1 and LP2. Pin LP2 has a path to the PLLAGND pin through a 100 $\Omega$  5% series resistor and a 0.01  $\mu$ F 10% series capacitor. The ground side of capacitor C1 and the PLLVSS pin should connect to the ground plane at a common point. All PLL loop filter traces should be kept to minimal length and should be wider than signal traces. Inductor L1 is connected to the 5V power supply on both the 82433LX and 82433NX.

Some circuit boards may require filtering the power circuit to the LBX PLL. The circuit shown in Figure 11 will typically enable the LBX PLL to have higher noise immunity than without. Pin PLLVDD is connected to the 5V V<sub>CC</sub> through a 10 $\Omega$  5% resistor. The PLLVDD and PLLVSS pins are bypassed with a 0.01  $\mu$ F 10% series capacitor.

The high order 82433NX LBX samples A11 at the falling edge of reset to configure the LBX for PLL test mode. When A11 is sampled low, the LBX is in normal operating mode. When A11 is sampled high, the LBX drives the internal HOLK from the PLL on the EOL pin. Note that A11 on the high order LBX is connected to the A27 line on the CPU address bus. This same address line is used to put the PCMC into PLL test mode.

	Mercury 60 MHz	Mercury 66 MHz	Neptune
R1	4.7 K $\Omega$	2.2 K $\Omega$	4.7 K $\Omega$
R2	100 $\Omega$	100 $\Omega$	100 $\Omega$
C2	0.01 $\mu$ F	0.01 $\mu$ F	0.01 $\mu$ F
R3	10 $\Omega$	10 $\Omega$	10 $\Omega$
C1	0.47 $\mu$ F	0.47 $\mu$ F	0.47 $\mu$ F
C1'	0.01 $\mu$ F	0.01 $\mu$ F	0.01 $\mu$ F

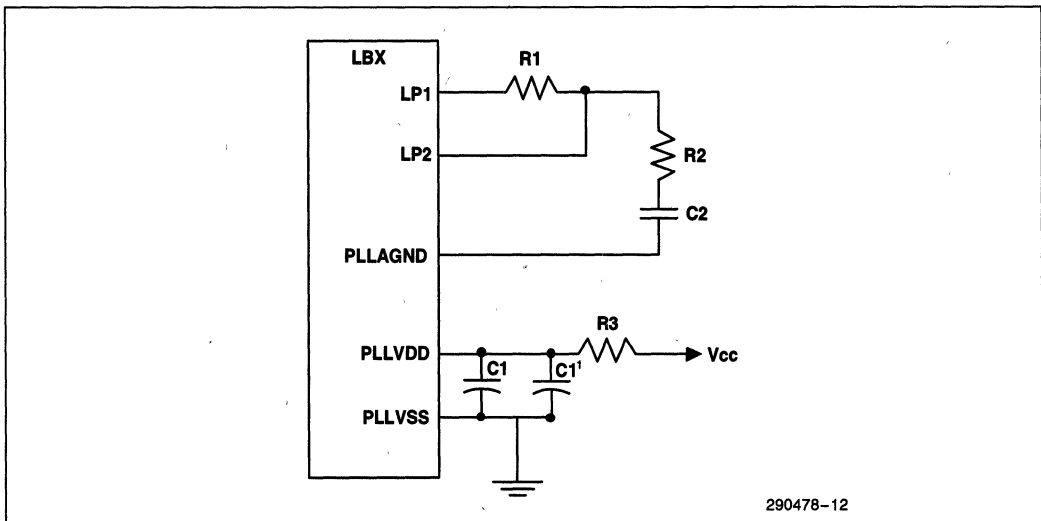

Figure 11. Loop Filter Circuit

290478-12

### 3.5 PCI Clock Considerations

There is a 1.25 ns clock skew specification between the PCMC and the LBX that must be adhered to for proper operation of the PCMC/LBX timing. As shown in Figure 12, the PCMC drives PCLKOUT to an external clock driver which supplies copies of PCLK to PCI devices, the LBXs, and back to the PCMC. The skew specification is defined as the dif-

ference in timing between the signal that appears at the PCMC PCLKIN input pin and the signal that appears at the LBX PCLK input pin. For both the low order LBX and the high order LBX, the PCLK rising and falling edges must not be more than 1.25 ns apart from the rising and falling edge of the PCMC PCLKIN signal.

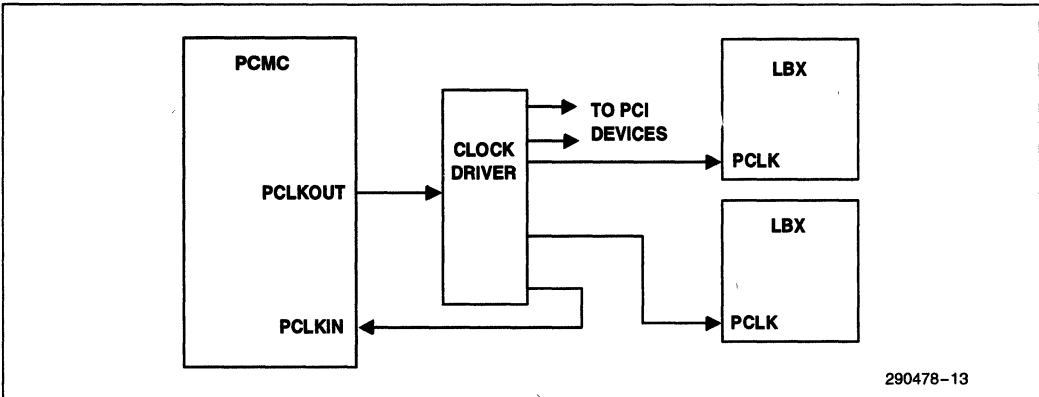

Figure 12. Clock Considerations

2



## 4.0 ELECTRICAL CHARACTERISTICS

### 4.1 Absolute Maximum Ratings

Table 4 lists stress ratings only. Functional operation at these maximums is not guaranteed. Functional operation conditions are given in Sections 4.2 and 4.3.

Extended exposure to the Absolute Maximum Ratings may affect device reliability.

Case Temperature under Bias ..... 0°C to +85°C

Storage Temperature ..... -40°C to +125°C

Voltage on Any Pin  
with Respect to Ground ..... -0.3 to V<sub>CC</sub> + 0.3V

Supply Voltage  
with Respect to V<sub>SS</sub> ..... -0.3 to +7.0V

Maximum Power Dissipation: ..... 1.4W (82433LX)

Maximum Total Power Dissipation: 1.4W (82433NX)

Maximum Power Dissipation, V<sub>CC3</sub> ..... 430 mW

The maximum total power dissipation in the 82433NX on the V<sub>CC</sub> and V<sub>CC3</sub> pins is 1.4W. The V<sub>CC3</sub> pins may draw as much as 430 mW, however, total power will not exceed 1.4W.

**NOTICE:** This data sheet contains information on products in the sampling and initial production phases of development. The specifications are subject to change without notice. Verify with your local Intel Sales office that you have the latest data sheet before finalizing a design.

*\*WARNING: Stressing the device beyond the "Absolute Maximum Ratings" may cause permanent damage. These are stress ratings only. Operation beyond the "Operating Conditions" is not recommended and extended exposure beyond the "Operating Conditions" may affect device reliability.*

### 4.2 Thermal Characteristics

The LBX is designed for operation at case temperatures between 0°C and 85°C. The thermal resistances of the package are given in the following tables.

**Table 4. Thermal Resistance**

Parameter	Air Flow Rate (Linear Feet per Minute)		
	0	400	600
$\theta_{JA}$ (°C/Watt)	51.9	37.1	34.8
$\theta_{JC}$ (°C/Watt)		10	

### 4.3 DC Characteristics

#### Host Interface Signals

A[15:0](t/s), D[31:0](t/s), HIG[4:0](in), HP[3:0](t/s)

#### Main Memory (DRAM) Interface Signals

MD[31:0](t/s), MP[3:0](t/s), MIG[2:0](in), MDLE(in)

#### PCI Interface Signals

AD[15:0](t/s), TRDY#(in), PIG[3:0](in), DRVPCI(in), EOL(t/s), PPOUT(t/s)

#### Reset and Clock Signals

HCLK(in), PCLK(in), RESET(in), LP1(out), LP2(in), TEST(in)

#### 4.3.1 82433LX LBX DC CHARACTERISTICS

Functional Operating Range:  $V_{CC} = 4.75\text{ V to }5.25\text{ V}$ ;  $T_{CASE} = 0^{\circ}\text{C to }+85^{\circ}\text{C}$

Symbol	Parameter	Min	Typical	Max	Unit	Notes
$V_{IL1}$	Input Low Voltage	-0.3		0.8	V	1
$V_{IH1}$	Input High Voltage	2.0		$V_{CC} + 0.3$	V	1
$V_{IL2}$	Input Low Voltage	-0.3		$0.3 \times V_{CC}$	V	2
$V_{IH2}$	Input High Voltage	$0.7 \times V_{CC}$		$V_{CC} + 0.3$	V	2
$V_{OL1}$	Output Low Voltage			0.4	V	3
$V_{OH1}$	Output High Voltage	2.4			V	3
$V_{OL2}$	Output Low Voltage			0.5	V	4
$V_{OH2}$	Output High Voltage	$V_{CC} - 0.5$			V	4
$I_{OL1}$	Output Low Current			1	mA	5
$I_{OH1}$	Output High Current	-1			mA	5
$I_{OL2}$	Output Low Current			3	mA	6
$I_{OH2}$	Output High Current	-2			mA	6

2



Functional Operating Range:  $V_{CC} = 4.75V$  to  $5.25V$ ;  $T_{CASE} = 0^{\circ}C$  to  $+85^{\circ}C$  (Continued)

Symbol	Parameter	Min	Typical	Max	Unit	Notes
$I_{OL3}$	Output Low Current			3	mA	7
$I_{OH3}$	Output High Current	-1			mA	7
$I_{IH}$	Input Leakage Current			+10	$\mu A$	
$I_{IL}$	Input Leakage Current			-10	$\mu A$	
$C_{IN}$	Input Capacitance		4.6		pF	
$C_{OUT}$	Output Capacitance		4.3		pF	
$C_{I/O}$	I/O Capacitance		4.6		pF	

**NOTES:**

- $V_{IL1}$  and  $V_{IH1}$  apply to the following signals: AD[15:0], A[15:0], D[31:0], HP[3:0], MD[31:0], MP[3:0], TRDY#, RESET, HCLK, PCLK
- $V_{IL2}$  and  $V_{IH2}$  apply to the following signals: HIG[4:0], PIG[3:0], MIG[2:0], MDLE, DRVPCI
- $V_{OL1}$  and  $V_{OH1}$  apply to the following signals: AD[15:0], A[15:0], D[31:0], HP[3:0], MD[31:0], MP[3:0]
- $V_{OL2}$  and  $V_{OH2}$  apply to the following signals: PPOUT, EOL
- $I_{OL1}$  and  $I_{OH1}$  apply to the following signals: PPOUT, EOL
- $I_{OL2}$  and  $I_{OH2}$  apply to the following signals: AD[15:0]
- $I_{OL3}$  and  $I_{OH3}$  apply to the following signals: A[15:0], D[31:0], HP[3:0], MD[31:0], MP[3:0]

**4.3.2 82433NX LBX DC CHARACTERISTICS**

Functional Operating Range:  $V_{CC} = 4.75V$  to  $5.25V$ ;  $V_{CC3} = 3.135$  to  $3.465V$ ,  $T_{CASE} = 0^{\circ}C$  to  $+85^{\circ}C$

Symbol	Parameter	Min	Typical	Max	Unit	Notes
$V_{IL1}$	Input Low Voltage	-0.3		0.8	V	1
$V_{IH1}$	Input High Voltage	2.0		$V_{CC} + 0.3$	V	1
$V_{IL2}$	Input Low Voltage	-0.3		$0.3 \times V_{CC}$	V	2
$V_{IH2}$	Input High Voltage	$0.7 \times V_{CC}$		$V_{CC} + 0.3$	V	2
$V_{IL3}$	Input Low Voltage	-0.3		0.8	V	3
$V_{IH3}$	Input High Voltage	2.0		$V_{CC3} + 0.3$	V	3
$V_{OL1}$	Output Low Voltage			0.4	V	4
$V_{OH1}$	Output High Voltage	2.4			V	4
$V_{OL2}$	Output Low Voltage			0.5	V	5
$V_{OH2}$	Output High Voltage	$V_{CC} - 0.5$			V	5
$I_{OL1}$	Output Low Current			1	mA	6
$I_{OH1}$	Output High Current	-1			mA	6
$I_{OL2}$	Output Low Current			3	mA	7
$I_{OH2}$	Output High Current	-2			mA	7

Functional Operating Range:  $V_{CC} = 4.75V$  to  $5.25V$ ;  $V_{CC3} = 3.135V$  to  $3.465V$ ,  
 $T_{CASE} = 0^{\circ}C$  to  $+85^{\circ}C$  (Continued)

Symbol	Parameter	Min	Typical	Max	Unit	Notes
$I_{OL3}$	Output Low Current			3	mA	8
$I_{OH3}$	Output High Current	-1			mA	8
$I_{IH}$	Input Leakage Current			+10	$\mu A$	
$I_{IL}$	Input Leakage Current			-10	$\mu A$	
$C_{IN}$	Input Capacitance		4.6		pF	
$C_{OUT}$	Output Capacitance		4.3		pF	
$C_{I/O}$	I/O Capacitance		4.6		pF	

**NOTES:**

1.  $V_{IL1}$  and  $V_{IH1}$  apply to the following signals: AD[15:0], MD[31:0], MP[3:0], TRDY#, RESET, HCLK, PCLK
2.  $V_{IL2}$  and  $V_{IH2}$  apply to the following signals: HIG[4:0], PIG[3:0], MIG[2:0], MDLE, DRVPCI
3.  $V_{IL3}$  and  $V_{IH3}$  apply to the following signals: A[15:0], D[31:0], HP[3:0]
4.  $V_{OL1}$  and  $V_{OH1}$  apply to the following signals: AD[15:0], A[15:0], D[31:0], HP[3:0], MD[31:0], MP[3:0]
5.  $V_{OL2}$  and  $V_{OH2}$  apply to the following signals: PPOUT, EOL
6.  $I_{OL1}$  and  $I_{OH1}$  apply to the following signals: PPOUT, EOL
7.  $I_{OL2}$  and  $I_{OH2}$  apply to the following signals: AD[15:0]
8.  $I_{OL3}$  and  $I_{OH3}$  apply to the following signals: A[15:0], D[31:0], HP[3:0], MD[31:0], MP[3:0]
9. The output buffers for A[15:0], D[31:0] and HP[3:0] are powered with  $V_{CC3}$  and therefore drive 3.3V signal levels.

2

#### 4.4 82433LX AC Characteristics

The AC specifications given in this section consist of propagation delays, valid delays, input setup requirements, input hold requirements, output float delays, output enable delays, clock high and low times and clock period specifications. Figure 13 through Figure 21 define these specifications. Sections 4.3.1 through 4.3.3 list the AC Specifications.

In Figure 13 through Figure 21  $V_T = 1.5V$  for the following signals: MD[31:0], MP[3:0], D[31:0], HP[3:0], A[15:0], AD[15:0], TRDY#, HCLK, PCLK, RESET, TEST.

$V_T = 2.5V$  for the following signals: HIG[4:0], PIG[3:0], MIG[2:0], MDLE, DRVPCI, PPOUT, EOL.

##### 4.4.1 HOST AND PCI CLOCK TIMING, 66 MHZ (82433LX)

Functional Operating Range:  $V_{CC} = 4.9V$  to  $5.25V$ ;  $T_{CASE} = 0^{\circ}C$  to  $+70^{\circ}C$

Symbol	Parameter	Min	Max	Figure	Notes
t1a	HCLK Period	15	20	18	
t1b	HCLK High Time	5		18	
t1c	HCLK Low Time	5		18	
t1d	HCLK Rise Time		1.5	19	
t1e	HCLK Fall Time		1.5	19	
t1f	HCLK Period Stability		$\pm 100$		ps <sup>1</sup>
t2a	PCLK Period	30		18	
t2b	PCLK High Time	12		18	
t2c	PCLK Low Time	12		18	
t2d	PCLK Rise Time		3	19	
t2e	PCLK Fall Time		3	19	
t3	HCLK to PCLK Skew	-7.2	5.8	21	

**NOTE:**

1. Measured on rising edge of adjacent clocks at 1.5 Volts.

4.4.2 COMMAND TIMING, 66 MHZ (82433LX)

Functional Operating Range:  $V_{CC} = 4.9V$  to  $5.25V$ ;  $T_{CASE} = 0^{\circ}C$  to  $+70^{\circ}C$

Symbol	Parameter	Min	Max	Figure	Notes
t10a	HIG[4:0] Setup Time to HCLK Rising	5.4		15	
t10b	HIG[4:0] Hold Time from HCLK Rising	0		15	
t11a	MIG[2:0] Setup Time to HCLK Rising	5.4		15	
t11b	MIG[2:0] Hold Time from HCLK Rising	0		15	
t12a	PIG[3:0] Setup Time to PCLK Rising	15.6		15	
t12b	PIG[3:0] Hold Time from PCLK Rising	-1.0		15	
t13a	MDLE Setup Time to HCLK Rising	5.7		15	
t13b	MDLE Hold Time to HCLK Rising	-0.3		15	
t14a	DRVPCI Setup Time to PCLK Rising	6.5		15	
t14b	DRVPCI Hold Time from PCLK Rising	-0.5		15	
t15a	RESET Setup Time to HCLK Rising	3.1		15	
t15b	RESET Hold Time from HCLK Rising	0.3		15	

2

#### 4.4.3 ADDRESS, DATA, TRDY #, EOL, TEST, TSCON AND PARITY TIMING, 66 MHz (82433LX)

Functional Operating Range:  $V_{CC} = 4.9V$  to  $5.25V$ ;  $T_{CASE} = 0^{\circ}C$  to  $+70^{\circ}C$

Symbol	Parameter	Min	Max	Figure	Notes
t20a	AD[15:0] Output Enable Delay from PCLK Rising	2		17	
t20b	AD[15:0] Valid Delay from PCLK Rising	2	11	14	1
t20c	AD[15:0] Setup Time to PCLK Rising	7		15	
t20d	AD[15:0] Hold Time from PCLK Rising	0		15	
t20e	AD[15:0] Float Delay from DRVPCI Falling	2	10	16	
t21a	TRDY # Setup Time to PCLK Rising	7		15	
t21b	TRDY # Hold Time from PCLK Rising	0		15	
t22a	D[31:0], HP[3:0] Output Enable Delay from HCLK Rising	0	7.7	17	2
t22b	D[31:0], HP[3:0] Float Delay from HCLK Rising	3.1	15.5	16	
t22c	D[31:0], HP[3:0] Float Delay from MDLE Rising	2	11.0	16	3
t22d	D[31:0], HP[3:0] Valid Delay from HCLK Rising	0	7.7	14	2
t22e	D[31:0], HP[3:0] Setup Time to HCLK Rising	3.0		15	
t22f	D[31:0], HP[3:0] Hold Time from HCLK Rising	0.3		15	
t23a	HA[15:0] Output Enable Delay from HCLK Rising	0	15.2	17	
t23b	HA[15:0] Float Delay from HCLK Rising	0	15.2	16	
t23c	HA[15:0] Valid Delay from HCLK Rising	0	16	14	7
t23cc	HA[15:0] Valid Delay from HCLK Rising	0	14.5		8
t23d	HA[15:0] Setup Time to HCLK Rising	15		15	4
t23e	HA[15:0] Setup Time to HCLK Rising	4.1		15	5
t23f	HA[15:0] Hold Time from HCLK Rising	0.3		15	
t24a	MD[31:0], MP[3:0] Valid Delay from HCLK Rising	0	12.0	14	6
t24b	MD[31:0], MP[3:0] Setup Time to HCLK Rising	4.0		15	
t24c	MD[31:0], MP[3:0] Hold Time from HCLK Rising	0.4		15	
t25	EOL, PPOUT Valid Delay from PCLK Rising	2.3	17.2	14	2
t26a	All Outputs Float Delay from TSCON Falling	0	30	16	
t26b	All Outputs Enable Delay from TSCON Rising	0	30	17	

#### NOTES:

1. Min: 0 pF, Max: 50 pF
2. 0 pF
3. When NOPC command sampled on previous rising HCLK on HIG[4:0]
4. CPU to PCI Transfers
5. When ADCPY command is sampled on HIG[4:0]
6. 50 pF
7. When DACPYL or DACPYH commands are sampled on HIG[4:0]
8. Inquire cycle

**4.4.4 HOST AND PCI CLOCK TIMING, 60 MHz (82433LX)**
**Functional Operating Range:  $V_{CC} = 4.75V$  to  $5.25V$ ;  $T_{CASE} = 0^{\circ}C$  to  $+85^{\circ}C$** 

Symbol	Parameter	Min	Max	Figure	Notes
t1a	HCLK Period	16.6	20	18	
t1b	HCLK High Time	5.5		18	
t1c	HCLK Low Time	5.5		18	
t1d	HCLK Rise Time		1.5	19	
t1e	HCLK Fall Time		1.5	19	
t1f	HCLK Period Stability		$\pm 100$		ps <sup>1</sup>
t2a	PCLK Period	33.33		18	
t2b	PCLK High Time	13		18	
t2c	PCLK Low Time	13		18	
t2d	PCLK Rise Time		3	19	
t2e	PCLK Fall Time		3	19	
t3	PCLK to PCMC PCLKIN: Input to Input Skew	-7.2	5.8	21	

**NOTES:**

1. Measured on rising edge of adjacent clocks at 1.5 Volts

**4.4.5 COMMAND TIMING, 60 MHz (82433LX)**
**Functional Operating Range:  $V_{CC} = 4.75V$  to  $5.25V$ ;  $T_{CASE} = 0^{\circ}C$  to  $+85^{\circ}C$** 

Symbol	Parameter	Min	Max	Figure	Notes
t10a	HIG[4:0] Setup Time to HCLK Rising	6.0		15	
t10b	HIG[4:0] Hold Time from HCLK Rising	0		15	
t11a	MIG[2:0] Setup Time to HCLK Rising	6.0		15	
t11b	MIG[2:0] Hold Time from HCLK Rising	0		15	
t12a	PIG[3:0] Setup Time to PCLK Rising	16.0		15	
t12b	PIG[3:0] Hold Time from PCLK Rising	0		15	
t13a	MDLE Setup Time to HCLK Rising	5.9		15	
t13b	MDLE Hold Time to HCLK Rising	-0.3		15	
t14a	DRVPCI Setup Time to PCLK Rising	7.0		15	
t14b	DRVPCI Hold Time from PCLK Rising	-0.5		15	
t15a	RESET Setup Time to HCLK Rising	3.4		15	
t15b	RESET Hold Time from HCLK Rising	0.4		15	

2

## 4.4.6 ADDRESS, DATA, TRDY #, EOL, TEST, TSCON AND PARITY TIMING, 60 MHz (82433LX)

Functional Operating Range:  $V_{CC} = 4.75V$  to  $5.25V$ ;  $T_{CASE} = 0^{\circ}C$  to  $+85^{\circ}C$ 

Symbol	Parameter	Min	Max	Figure	Notes
t20a	AD[15:0] Output Enable Delay from PCLK Rising	2		17	
t20b	AD[15:0] Valid Delay from PCLK Rising	2	11	14	1
t20c	AD[15:0] Setup Time to PCLK Rising	7		15	
t20d	AD[15:0] Hold Time from PCLK Rising	0		15	
t20e	AD[15:0] Float Delay from DRVPCI Falling	2	10	16	
t21a	TRDY # Setup Time to PCLK Rising	7		15	
t21b	TRDY # Hold Time from PCLK Rising	0		15	
t22a	D[31:0], HP[3:0] Output Enable Delay from HCLK Rising	0	7.9	17	2
t22b	D[31:0], HP[3:0] Float Delay from HCLK Rising	3.1	15.5	16	
t22c	D[31:0], HP[3:0] Float Delay from MDLE Rising	2	11.0	16	3
t22d	D[31:0], HP[3:0] Valid Delay from HCLK Rising	0	7.8	14	2
t22e	D[31:0], HP[3:0] Setup Time to HCLK Rising	3.4		15	
t22f	D[31:0], HP[3:0] Hold Time from HCLK Rising	0.3		15	
t23a	HA[15:0] Output Enable Delay from HCLK Rising	0	15.2	17	
t23b	HA[15:0] Float Delay from HCLK Rising	0	15.2	16	
t23c	HA[15:0] Valid Delay from HCLK Rising	0	18.5	14	7
t23cc	HA[15:0] Valid Delay from HCLK Rising	0	15.5		8
t23d	HA[15:0] Setup Time to HCLK Rising	15.0		15	4
t23e	HA[15:0] Setup Time to HCLK Rising	4.1		15	5
t23f	HA[15:0] Hold Time from HCLK Rising	0.3		15	
t24a	MD[31:0], MP[3:0] Valid Delay from HCLK Rising	0	12.0	14	6
t24b	MD[31:0], MP[3:0] Setup Time to HCLK Rising	4.4		15	
t24c	MD[31:0], MP[3:0] Hold Time from HCLK Rising	1.0		15	
t25	EOL, PPOUT Valid Delay from PCLK Rising	2.3	17.2	14	2
t26a	All Outputs Float Delay from TSCON Falling	0	30	16	
t26b	All Outputs Enable Delay from TSCON Rising	0	30	17	

**NOTES:**

1. Min: 0 pF, Max: 50 pF
2. 0 pF
3. When NOPC command sampled on previous rising HCLK on HIG[4:0]
4. CPU to PCI Transfers
5. When ADCPY command is sampled on HIG[4:0]
6. 50 pF
7. When DACPYL or DACPYH commands are sampled on HIG[4:0]
8. Inquire cycle

#### 4.4.7 TEST TIMING (82433LX)

Functional Operating Range:  $V_{CC} = 4.75V$  to  $5.25V$ ;  $T_{CASE} = 0^{\circ}C$  to  $+85^{\circ}C$

Symbol	Parameter	Min	Max	Figure	Notes
t30	All Test Signals Setup Time to HCLK/PCLK Rising	10.0			In PLL Bypass Mode
t31	All Test Signals Hold Time to HCLK/PCLK Rising	12.0			In PLL Bypass Mode
t32	Test Setup Time to HCLK/PCLK Rising	15.0		15	
t33	Test Hold Time to HCLK/PCLK Rising	5.0		15	
t34	PPOUT Valid Delay from PCLK Rising	0.0	500	15	In PLL Bypass Mode

2

#### 4.5 82433NX AC Characteristics

The AC specifications given in this section consist of propagation delays, valid delays, input setup requirements, input hold requirements, output float delays, output enable delays, clock high and low times and clock period specifications. Figure 13 through Figure 21 define these specifications. Section 4.5 lists the AC Specifications.

In Figure 13 through Figure 21  $V_T = 1.5V$  for the following signals: MD[31:0], MP[3:0], D[31:0], HP[3:0], A[15:0], AD[15:0], TRDY#, HCLK, PCLK, RESET, TEST.

$V_T = 2.5V$  for the following signals: HIG[4:0], PIG[3:0], MIG[2:0], MDLE, DRVPCI, PPOUT, EOL.

#### 4.5.1 HOST AND PCI CLOCK TIMING, (82433NX)

Functional Operating Range:  $V_{CC} = 4.75V$  to  $5.25V$ ;  $V_{CC3} = 3.135V$  to  $3.465V$ ,  $T_{CASE} = 0^{\circ}C$  to  $+85^{\circ}C$

Symbol	Parameter	Min	Max	Figure	Notes
t1a	HCLK Period	15	20	18	
t1b	HCLK High Time	5		18	
t1c	HCLK Low Time	5		18	
t1d	HCLK Rise Time		1.5	19	
t1e	HCLK Fall Time		1.5	19	
t1f	HCLK Period Stability		$\pm 100$		ps <sup>1</sup>
t2a	PCLK Period	30		18	
t2b	PCLK High Time	12		18	
t2c	PCLK Low Time	12		18	
t2d	PCLK Rise Time		3	19	
t2e	PCLK Fall Time		3	19	
t3	HCLK to PCLK Skew	-7.2	5.8	21	

**NOTE:**

1. Measured on rising edge of adjacent clocks at 1.5 Volts.



## 4.5.2 COMMAND TIMING, (82433NX)

Functional Operating Range:  $V_{CC} = 4.75V$  to  $5.25V$ ;  $V_{CC3} = 3.135V$  to  $3.465V$ ,  $T_{CASE} = 0^{\circ}C$  to  $+85^{\circ}C$ 

Symbol	Parameter	Min	Max	Figure	Notes
t10a	HIG[4:0] Setup Time to HCLK Rising	5.5		15	
t10b	HIG[4:0] Hold Time from HCLK Rising	0		15	
t11a	MIG[2:0] Setup Time to HCLK Rising	5.5		15	
t11b	MIG[2:0] Hold Time from HCLK Rising	0		15	
t12a	PIG[3:0] Setup Time to PCLK Rising	14.5		15	
t12b	PIG[3:0] Hold Time from PCLK Rising	0.0		15	
t13a	MDLE Setup Time to HCLK Rising	5.5		15	
t13b	MDLE Hold Time to HCLK Rising	-0.3		15	
t14a	DRVPCI Setup Time to PCLK Rising	7.0		15	
t14b	DRVPCI Hold Time from PCLK Rising	-0.5		15	
t15a	RESET Setup Time to HCLK Rising	3.4		15	
t15b	RESET Hold Time from HCLK Rising	0.4		15	

## 4.5.3 ADDRESS, DATA, TRDY #, EOL, TEST, TSCON AND PARITY TIMING, (82433NX)

Functional Operating Range:  $V_{CC} = 4.75V$  to  $5.25V$ ;  $V_{CC3} = 3.135V$  to  $3.465V$ ,  $T_{CASE} = 0^{\circ}C$  to  $+85^{\circ}C$ 

Symbol	Parameter	Min	Max	Figure	Notes
t20a	AD[15:0] Output Enable Delay from PCLK Rising	2		17	
t20b	AD[15:0] Valid Delay from PCLK Rising	2	11	14	1
t20c	AD[15:0] Setup Time to PCLK Rising	7		15	
t20d	AD[15:0] Hold Time from PCLK Rising	0		15	
t20e	AD[15:0] Float Delay from DRVPCI Falling	2	10	16	
t21a	TRDY # Setup Time to PCLK Rising	7		15	
t21b	TRDY # Hold Time from PCLK Rising	0		15	
t22a	D[31:0], HP[3:0] Output Enable Delay from HCLK Rising	0	7.5	17	2
t22b	D[31:0], HP[3:0] Float Delay from HCLK Rising	3.1	15.5	16	
t22c	D[31:0], HP[3:0] Float Delay from MDLE Rising	2	9.5	16	3
t22d	D[31:0], HP[3:0] Valid Delay from HCLK Rising	0	7.5	14	2
t22e	D[31:0], HP[3:0] Setup Time to HCLK Rising	3.1		15	
t22f	D[31:0], HP[3:0] Hold Time from HCLK Rising	0.3		15	

Functional Operating Range:  $V_{CC} = 4.75V$  to  $5V$ ;  $V_{CC3} = 3.135V$  to  $3.465V$ ,  
 $T_{CASE} = 0^{\circ}C$  to  $+85^{\circ}C$  (Continued)

Symbol	Parameter	Min	Max	Figure	Notes
t23a	HA[15:0] Output Enable Delay from HCLK Rising	0	13.5	17	
t23b	HA[15:0] Float Delay from HCLK Rising	0	13.5	16	
t23c	HA[15:0] Valid Delay from HCLK Rising	0	17.5	14	7
t23cc	HA[15:0] Valid Delay from HCLK Rising	0	13.5		8
t23d	HA[15:0] Setup Time to HCLK Rising	15		15	4
t23e	HA[15:0] Setup Time to HCLK Rising	4.2		15	5
t23f	HA[15:0] Hold Time from HCLK Rising	0.3		15	
t24a	MD[31:0], MP[3:0] Valid Delay from HCLK Rising	0	12.0	14	6
t24b	MD[31:0], MP[3:0] Setup Time to HCLK Rising	4.4		15	
t24c	MD[31:0], MP[3:0] Hold Time from HCLK Rising	1.0		15	
t25	EOL, PPOUT Valid Delay from PCLK Rising	2.3	17.2	14	2
t26a	All Outputs Float Delay from TSCON Falling	0	30	16	
t26b	All Outputs Enable Delay from TSCON Rising	0	30	17	

**NOTE:**

1. Min: 0 pF, Max: 50 pF
2. 0 pF
3. When NOPC command sampled on previous rising HCLK on HIG[4:0]
4. CPU to PCI Transfers
5. When ADCPY command is sampled on HIG[4:0]
6. 50 pF
7. When DACPYL or DACPYH commands are sampled on HIG[4:0]
8. Inquire cycle

**4.5.4 TEST TIMING (82433NX)**

Functional Operating Range:  $V_{CC} = 4.75V$  to  $5.25V$ ;  $V_{CC3} = 3.135V$  to  $3.465V$ ,  $T_{CASE} = 0^{\circ}C$  to  $+85^{\circ}C$

Symbol	Parameter	Min	Max	Figure	Notes
t30	All Test Signals Setup Time to HCLK/ PCLK Rising	10.0			In PLL Bypass Mode
t31	All Test Signals Hold Time to HCLK/ PCLK Rising	12.0			In PLL Bypass Mode
t32	Test Setup Time to HCLK/PCLK Rising	15.0		15	
t33	Test Hold Time to HCLK/PCLK Rising	5.0		15	
t34	PPOUT Valid Delay from PCLK Rising	0.0	500	15	In PLL Bypass Mode

2

4.5.5 TIMING DIAGRAMS

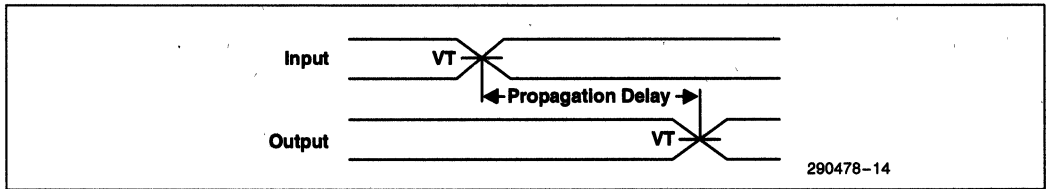

Figure 13. Propagation Delay

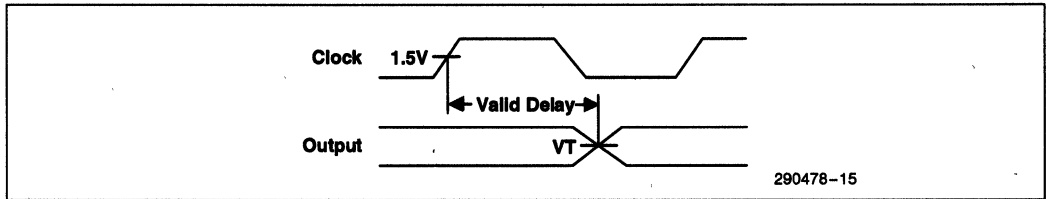

Figure 14. Valid Delay from Rising Clock Edge

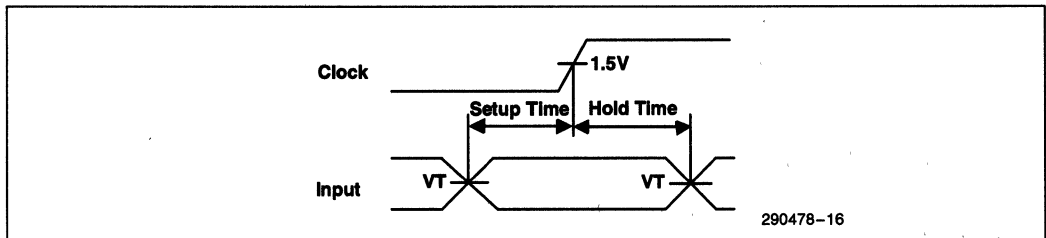

Figure 15. Setup and Hold Times

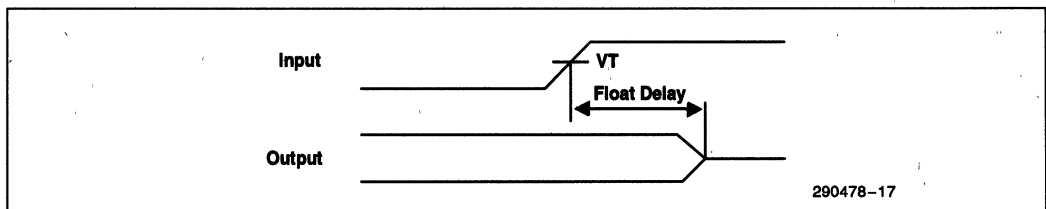

Figure 16. Float Delay

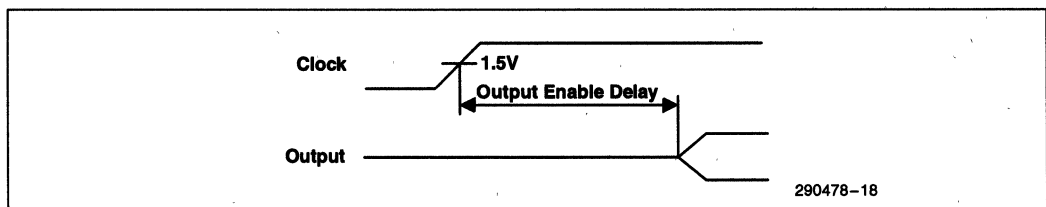
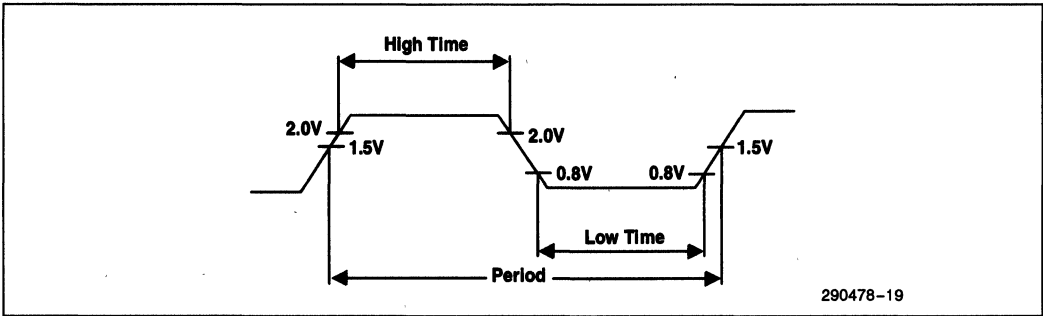
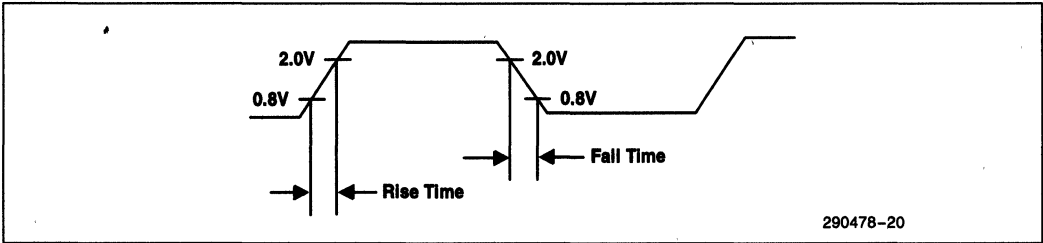

Figure 17. Output Enable Delay



290478-19

Figure 18. Clock High and Low Times and Period



290478-20

Figure 19. Clock Rise and Fall Times

2

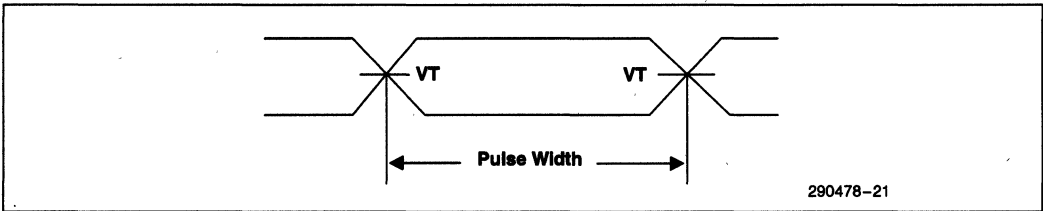

290478-21

Figure 20. Pulse Width

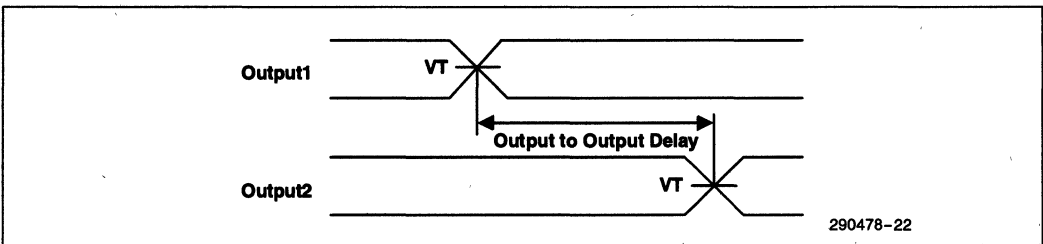

290478-22

Figure 21. Output to Output Delay

## 5.0 PINOUT AND PACKAGE INFORMATION

### 5.1 Pin Assignment

Pins 1, 22, 41, 61, and 150 are VDD3 pins on the 82433NX. These pins must be connected to the 3.3V power supply. All other VDD pins on the 82433NX must be connected to the 5V power supply.

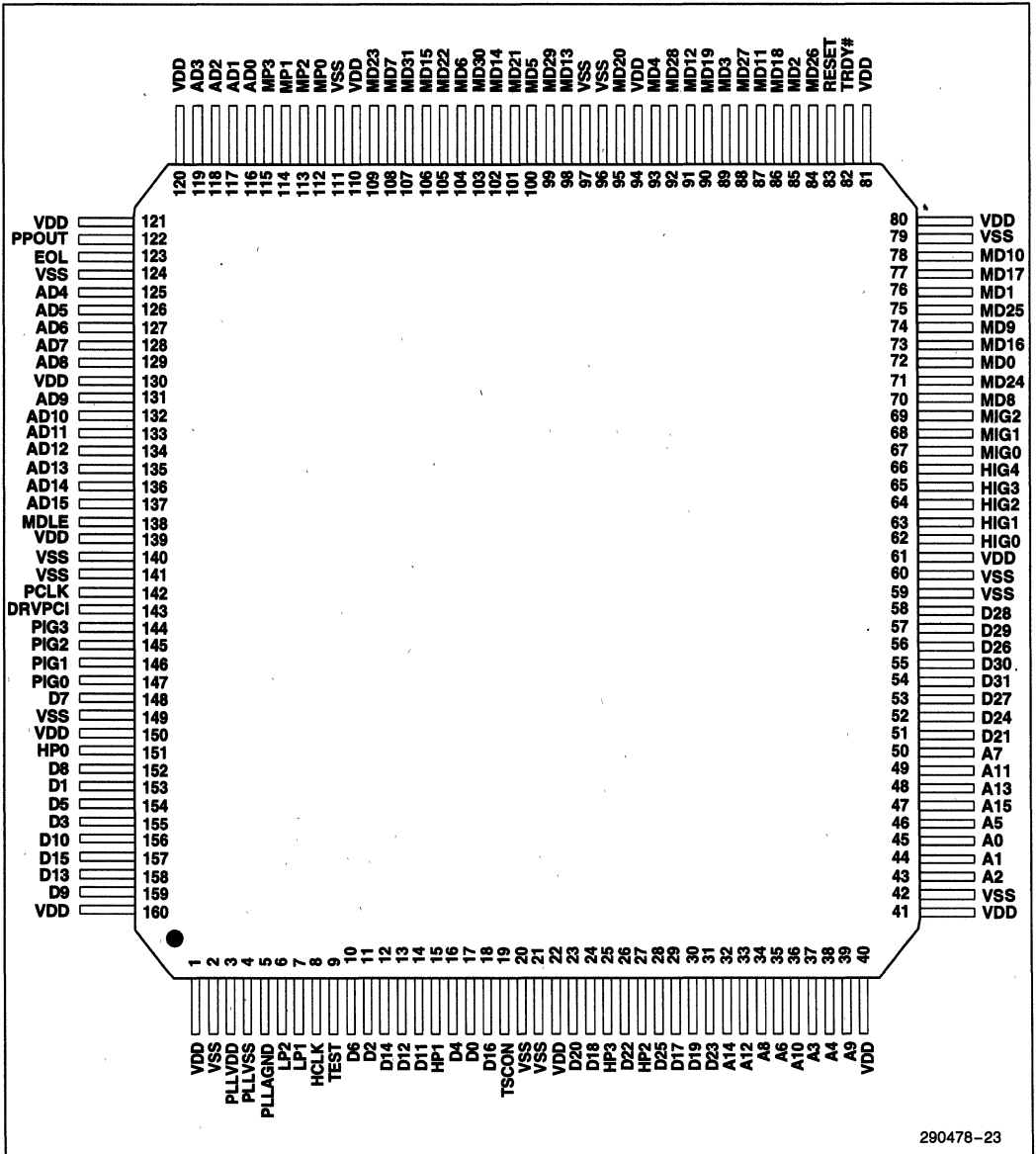

Figure 22. 82433LX and 82433NX Pin Assignment

**Table 5. 82433LX and 82433NX Numerical Pin Assignment**

Pin Name	Pin #	Type
V <sub>DD</sub> (82433LX) V <sub>DD3</sub> (82433NX)	1	V
V <sub>SS</sub>	2	V
PLL <sub>VDD</sub>	3	V
PLL <sub>VSS</sub>	4	V
PLLAGND	5	V
LP2	6	in
LP1	7	out
HCLK	8	in
TEST	9	in
D6	10	t/s
D2	11	t/s
D14	12	t/s
D12	13	t/s
D11	14	t/s
HP1	15	t/s
D4	16	t/s
D0	17	t/s
D16	18	t/s
TSCON	19	in
V <sub>SS</sub>	20	V
V <sub>SS</sub>	21	V
V <sub>DD</sub> (82433LX) V <sub>DD3</sub> (82433NX)	22	V
D20	23	t/s
D18	24	t/s
HP3	25	t/s

Pin Name	Pin #	Type
D22	26	t/s
HP2	27	t/s
D25	28	t/s
D17	29	t/s
D19	30	t/s
D23	31	t/s
A14	32	t/s
A12	33	t/s
A8	34	t/s
A6	35	t/s
A10	36	t/s
A3	37	t/s
A4	38	t/s
A9	39	t/s
V <sub>DD</sub>	40	V
V <sub>DD</sub> (82433LX) V <sub>DD3</sub> (82433NX)	41	V
V <sub>SS</sub>	42	V
A2	43	t/s
A1	44	t/s
A0	45	t/s
A5	46	t/s
A15	47	t/s
A13	48	t/s
A11	49	t/s
A7	50	t/s

Pin Name	Pin #	Type
D21	51	t/s
D24	52	t/s
D27	53	t/s
D31	54	t/s
D30	55	t/s
D26	56	t/s
D29	57	t/s
D28	58	t/s
V <sub>SS</sub>	59	V
V <sub>SS</sub>	60	V
V <sub>DD</sub> (82433LX) V <sub>DD3</sub> (82433NX)	61	V
HIG0	62	in
HIG1	63	in
HIG2	64	in
HIG3	65	in
HIG4	66	in
MIG0	67	in
MIG1	68	in
MIG2	69	in
MD8	70	t/s
MD24	71	t/s
MD0	72	t/s
MD16	73	t/s
MD9	74	t/s
MD25	75	t/s

**2**

Table 5. 82433LX and 82433NX Numerical Pin Assignment (Continued)

Pin Name	Pin #	Type
MD1	76	t/s
MD17	77	t/s
MD10	78	t/s
V <sub>SS</sub>	79	V
V <sub>DD</sub>	80	V
V <sub>DD</sub>	81	V
TRDY#	82	in
RESET	83	in
MD26	84	t/s
MD2	85	t/s
MD18	86	t/s
MD11	87	t/s
MD27	88	t/s
MD3	89	t/s
MD19	90	t/s
MD12	91	t/s
MD28	92	t/s
MD4	93	t/s
V <sub>DD</sub>	94	V
MD20	95	t/s
V <sub>SS</sub>	96	V
V <sub>SS</sub>	97	V
MD13	98	t/s
MD29	99	t/s
MD5	100	t/s
MD21	101	t/s
MD14	102	t/s
MD30	103	t/s
MD6	104	t/s

Pin Name	Pin #	Type
MD22	105	t/s
MD15	106	t/s
MD31	107	t/s
MD7	108	t/s
MD23	109	t/s
V <sub>DD</sub>	110	V
V <sub>SS</sub>	111	V
MP0	112	t/s
MP2	113	t/s
MP1	114	t/s
MP3	115	t/s
AD0	116	t/s
AD1	117	t/s
AD2	118	t/s
AD3	119	t/s
V <sub>DD</sub>	120	V
V <sub>DD</sub>	121	V
PPOUT	122	t/s
EOL	123	t/s
V <sub>SS</sub>	124	V
AD4	125	t/s
AD5	126	t/s
AD6	127	t/s
AD7	128	t/s
AD8	129	t/s
V <sub>DD</sub>	130	V
AD9	131	t/s
AD10	132	t/s

Pin Name	Pin #	Type
AD11	133	t/s
AD12	134	t/s
AD13	135	t/s
AD14	136	t/s
AD15	137	t/s
MDLE	138	in
V <sub>DD</sub>	139	V
V <sub>SS</sub>	140	V
V <sub>SS</sub>	141	V
PCLK	142	in
DRVPCI	143	in
PIG3	144	in
PIG2	145	in
PIG1	146	in
PIG0	147	in
D7	148	t/s
V <sub>SS</sub>	149	V
V <sub>DD</sub> (82433LX)	150	V
V <sub>DD3</sub> (82433NX)		
HP0	151	t/s
D8	152	t/s
D1	153	t/s
D5	154	t/s
D3	155	t/s
D10	156	t/s
D15	157	t/s
D13	158	t/s
D9	159	t/s
V <sub>DD</sub>	160	V

**Table 6. 82433LX and 82433NX Alphabetical Pin Assignment List**

Pin Name	Pin #	Type
A0	45	t/s
A1	44	t/s
A2	43	t/s
A3	37	t/s
A4	38	t/s
A5	46	t/s
A6	35	t/s
A7	50	t/s
A8	34	t/s
A9	39	t/s
A10	36	t/s
A11	49	t/s
A12	33	t/s
A13	48	t/s
A14	32	t/s
A15	47	t/s
AD0	116	t/s
AD1	117	t/s
AD2	118	t/s
AD3	119	t/s
AD4	125	t/s
AD5	126	t/s
AD6	127	t/s
AD7	128	t/s
AD8	129	t/s
AD9	131	t/s
AD10	132	t/s
AD11	133	t/s
AD12	134	t/s

Pin Name	Pin #	Type
AD13	135	t/s
AD14	136	t/s
AD15	137	t/s
D0	17	t/s
D1	153	t/s
D2	11	t/s
D3	155	t/s
D4	16	t/s
D5	154	t/s
D6	10	t/s
D7	148	t/s
D8	152	t/s
D9	159	t/s
D10	156	t/s
D11	14	t/s
D12	13	t/s
D13	158	t/s
D14	12	t/s
D15	157	t/s
D16	18	t/s
D17	29	t/s
D18	24	t/s
D19	30	t/s
D20	23	t/s
D21	51	t/s
D22	26	t/s
D23	31	t/s
D24	52	t/s
D25	28	t/s

Pin Name	Pin #	Type
D26	56	t/s
D27	53	t/s
D28	58	t/s
D29	57	t/s
D30	55	t/s
D31	54	t/s
DRVPCI	143	in
EOL	123	t/s
HCLK	8	in
HIG0	62	in
HIG1	63	in
HIG2	64	in
HIG3	65	in
HIG4	66	in
HP0	151	t/s
HP1	15	t/s
HP2	27	t/s
HP3	25	t/s
LP1	7	out
LP2	6	in
MD0	72	t/s
MD1	76	t/s
MD2	85	t/s
MD3	89	t/s
MD4	93	t/s
MD5	100	t/s
MD6	104	t/s
MD7	108	t/s
MD8	70	t/s

**2**



Table 6. 82433LX and 82433NX Alphabetical Pin Assignment List (Continued)

Pin Name	Pin #	Type
MD9	74	t/s
MD10	78	t/s
MD11	87	t/s
MD12	91	t/s
MD13	98	t/s
MD14	102	t/s
MD15	106	t/s
MD16	73	t/s
MD17	77	t/s
MD18	86	t/s
MD19	90	t/s
MD20	95	t/s
MD21	101	t/s
MD22	105	t/s
MD23	109	t/s
MD24	71	t/s
MD25	75	t/s
MD26	84	t/s
MD27	88	t/s
MD28	92	t/s
MD29	99	t/s
MD30	103	t/s
MD31	107	t/s
MDLE	138	in
MIG0	67	in

Pin Name	Pin #	Type
MIG1	68	in
MIG2	69	in
MP0	112	t/s
MP1	114	t/s
MP2	113	t/s
MP3	115	t/s
PCLK	142	in
PIG0	147	in
PIG1	146	in
PIG2	145	in
PIG3	144	in
PLLAGND	5	V
PLLVD	3	V
PLLVS	4	V
PPOUT	122	t/s
RESET	83	in
TEST	9	in
TRDY	82	in
TSCON	19	in
V <sub>DD</sub> (82433LX) V <sub>DD3</sub> (82433NX)	1	V
V <sub>DD</sub> (82433LX) V <sub>DD3</sub> (82433NX)	22	V
V <sub>DD</sub>	40	V
V <sub>DD</sub> (82433LX) V <sub>DD3</sub> (82433NX)	41	V
V <sub>DD</sub> (82433LX) V <sub>DD3</sub> (82433NX)	61	V

Pin Name	Pin #	Type
V <sub>DD</sub>	80	V
V <sub>DD</sub>	81	V
V <sub>DD</sub>	94	V
V <sub>DD</sub>	110	V
V <sub>DD</sub>	120	V
V <sub>DD</sub>	121	V
V <sub>DD</sub>	130	V
V <sub>DD</sub>	139	V
V <sub>DD</sub> (82433LX) V <sub>DD3</sub> (82433NX)	150	V
V <sub>DD</sub>	160	V
V <sub>SS</sub>	2	V
V <sub>SS</sub>	20	V
V <sub>SS</sub>	21	V
V <sub>SS</sub>	42	V
V <sub>SS</sub>	59	V
V <sub>SS</sub>	60	V
V <sub>SS</sub>	79	V
V <sub>SS</sub>	96	V
V <sub>SS</sub>	97	V
V <sub>SS</sub>	111	V
V <sub>SS</sub>	124	V
V <sub>SS</sub>	140	V
V <sub>SS</sub>	141	V
V <sub>SS</sub>	149	V

## 5.2 Package Information

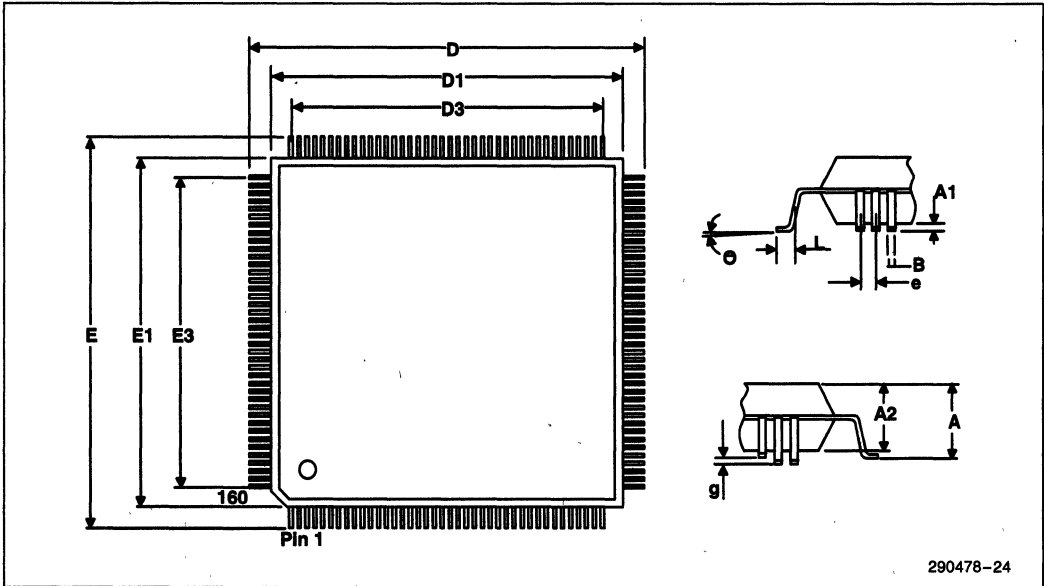

Figure 23. 82433LX and 82433NX 160-Pin QFP Package

Table 7. 160-Pin QFP Package Values

Symbol	Min Value (mm)	Max Value (mm)
A		4.45
A1	0.25	0.65
A2	3.30	3.80
B	0.20	0.40
D	31.00	32.40
D1	27.80	28.20
D3		25.55

Symbol	Min Value (mm)	Max Value (mm)
E	31.60	32.40
E1	27.80	28.20
E3		25.55
e		0.65
L	0.60	1.00
$\theta$	0°	10°
g		0.1

2

## 6.0 TESTABILITY

The TSCON pin may be used to help test circuits surrounding the LBX. During normal operations, the TSCON pin must be tied to VCC or connected to VCC through a pull-up resistor. All LBX outputs are tri-stated when the TSCON pin is held low or grounded.

### 6.1 NAND Tree

A NAND tree is provided in the LBX for Automated Test Equipment (ATE) board level testing. The NAND tree allows the tester to set the connectivity of each of the LBX signal pins.

The following steps must be taken to put the LBX into PLL bypass mode and enable the NAND tree. First, to enable PLL bypass mode, drive RESET inactive, TEST active, and the DCPWA command (0100) on the PIG[3:0] lines. Then drive PCLK from low to high. DRVPCI must be held low on all rising edges of PCLK during testing in order to ensure that the LBX does not drive the AD[15:0] lines. The host and memory buses are tri-stated by driving NOPM

(000) and NOPC (00000) on the MIG[2:0] and HIG[4:0] lines and driving two rising edges on HCLK. A rising edge on PCLK with RESET high will cause the LBXs to exit PLL bypass mode. TEST must remain high throughout the use of the NAND tree. The combination of TEST and DRVPCI high with a rising edge of PCLK must be avoided. TSCON must be driven high throughout testing since driving it low would tri-state the output of the NAND tree. A 10 ns hold time is required on all inputs sampled by PCLK or HCLK when in PLL bypass mode.

#### 6.1.1 TEST VECTOR TABLE

The following test vectors can be applied to the 82433LX and 82433NX to put it into PLL bypass mode and to enable NAND tree testing.

#### 6.1.2 NAND TREE TABLE

Table 9 shows the sequence of the NAND tree in the 82433LX and 82433NX. Non-inverting inputs are driven directly into the input of a NAND gate in the tree. Inverting inputs are driven into an inverter before going into the NAND tree. The output of the NAND tree is driven on the PPOUT pin.

**Table 8. Test Vectors to put LBX Into PLL Bypass and Enable NAND Tree Testing**

LBX Pin/Vector#	1	2	3	4	5	6	7	8	9	10	11
PCLK	0	1	0	0	1	1	1	1	1	1	1
PIG[3:0]	0h	0h	0h	4h	4h	4h	4h	4h	4h	4h	4h
RESET	1	1	1	0	0	0	1	1	1	1	1
HCLK	0	0	0	0	0	0	0	1	0	1	0
MIG[2:0]	0h	0h	0h	0h	0h	0h	0h	0h	0h	0h	0h
HIG[4:0]	0h	0h	0h	0h	0h	0h	0h	0h	0h	0h	0h
TEST	1	1	1	1	1	1	1	1	1	1	1
DRVPCI	0	0	0	0	0	0	0	0	0	0	0

Table 9. NAND Tree Sequence

Order	Pin #	Signal	Non-Inverting
1	10	D6	Y
2	11	D2	Y
3	12	D14	Y
4	13	D12	Y
5	14	D11	Y
6	15	HP1	Y
7	16	D4	Y
8	17	D0	Y
9	18	D16	Y
10	23	D20	Y
11	24	D18	Y
12	25	HP3	Y
13	26	D22	Y
14	27	HP2	Y
15	28	D25	Y
16	29	D17	Y
17	30	D19	Y
18	31	D23	Y
19	32	A14	Y
20	33	A12	Y
21	34	A8	Y
22	35	A6	Y
23	36	A10	Y
24	37	A3	Y
25	38	A4	Y
26	39	A9	Y

Order	Pin #	Signal	Non-Inverting
27	43	A2	Y
28	44	A1	Y
29	45	A0	Y
30	46	A5	Y
31	47	A15	Y
32	48	A13	Y
33	49	A11	Y
34	50	A7	Y
35	51	D21	Y
36	52	D24	Y
37	53	D27	Y
38	54	D31	Y
39	55	D30	Y
40	56	D26	Y
41	57	D29	Y
42	58	D28	Y
43	62	HIG0	Y
44	63	HIG1	Y
45	64	HIG2	Y
46	65	HIG3	Y
47	66	HIG4	Y
48	67	MIG0	N
49	68	MIG1	N
50	69	MIG2	N
51	70	MD8	N
52	71	MD24	N

Order	Pin #	Signal	Non-Inverting
53	72	MD0	N
54	73	MD16	N
55	74	MD9	N
56	75	MD25	N
57	76	MD1	N
58	77	MD17	N
59	78	MD10	N
60	82	TRDY#	Y
61	83	RESET	N
62	84	MD26	N
63	85	MD2	N
64	86	MD18	N
65	87	MD11	N
66	88	MD27	N
67	89	MD3	N
68	90	MD19	N
69	91	MD12	N
70	92	MD28	N
71	93	MD4	N
72	95	MD20	N
73	98	MD13	N
74	99	MD29	N
75	100	MD5	N
76	101	MD21	N
77	102	MD14	N
78	103	MD30	N

Table 9. NAND Tree Sequence (Continued)

Order	Pin #	Signal	Non-Inverting
79	104	MD6	N
80	105	MD22	N
81	106	MD15	N
82	107	MD31	N
83	108	MD7	N
84	109	MD23	N
85	112	MP0	N
86	113	MP2	N
87	114	MP1	N
88	115	MP3	N
89	116	AD0	Y
90	117	AD1	Y
91	118	AD2	Y
82	119	AD3	Y
93	123	EOL	Y

Order	Pin #	Signal	Non-Inverting
94	125	AD4	Y
95	126	AD5	Y
96	127	AD6	Y
97	128	AD7	Y
98	129	AD8	Y
99	131	AD9	Y
100	132	AD10	Y
101	133	AD11	Y
102	134	AD12	Y
103	135	AD13	Y
104	136	AD14	Y
105	137	AD15	Y
106	138	MDLE	Y
107	143	DRVPCI	N

Order	Pin #	Signal	Non-Inverting
108	144	PIG3	N
109	145	PIG2	N
110	146	PIG1	N
111	147	PIG0	N
112	148	D7	Y
113	151	HP0	Y
114	152	D8	Y
115	153	D1	Y
116	154	D5	Y
117	155	D3	Y
118	156	D10	Y
119	157	D15	Y
120	158	D13	Y
121	159	D9	Y

## 6.2 PLL Test Mode

The high order 82433NX LBX samples A11 at the falling edge of reset to configure the LBX for PLL test mode. When A11 is sampled low, the LBX is in normal operating mode. When A11 is sampled high, the LBX drives the internal HCLK from the PLL on the EOL pin.