

apricot

80486, 80486SX and 80487SX are trademarks of Intel Corporation.

Micro Channel is a trademark of International Business Machines Corporation.

Adaptec is a registered trademark of Adaptec Inc.

Information contained in this document is subject to change without notice and does not represent a commitment on the part of Apricot Computers Limited. The software described in this manual is furnished under a license agreement. The software may be used or copied only in accordance with the terms of this agreement.

It is against the law to copy any disk supplied for any other purpose than the purchaser's personal use.

All rights reserved; no use or disclosure without written consent.

Copyright © Apricot Computers Limited 1991

Published by
Apricot Computers Limited
3500 Parkside
Birmingham Business Park
B37 7YS

 MITSUBISHI ELECTRIC

Printed in the United Kingdom

Part no. 14829731

Contents

Introduction	2
Antistatic precautions	3
Power down procedure	4
Power up procedure	5
Preparing the system unit	6
Removing the side panel	7
Adapter cards	8
Installing memory modules	11
Co-processor	15
Supplier upgrades	17

Introduction

This guide contains instructions on installing expansion cards, extra memory and a co-processor in your computer. This document should be your only source of information when installing any of these.

You should read this document before purchasing extra memory or a co-processor. If, having read the relevant instructions, you are not confident about installing the upgrade, you may wish to have your supplier or service organization install it for you.

Before you start installing an upgrade you should be thoroughly familiar with all the relevant instructions in this guide.

Warning

Never carry out any work on the equipment with power applied. Always switch off at the mains, isolate the batteries and remove the power lead from the equipment before starting work.

At the rear of this guide is some information about CPU module and drive upgrades. These options are not user installable items, only competent service personnel may install them.

Anti-static precautions

All electronic components and equipments are sensitive to static electricity. Even small electrostatic discharges can render components useless or severely shorten their working life, therefore you should always take preventive measures.

No work should be carried out on any item unless it is in a Special Handling Area (SHA) as defined in BS5783. In general this involves:

- * a common earth point
- * an earthed bench or bench mat
- * an earthed wrist strap

Note

An anti-static earthing point is provided on the rear panel.

Power down procedure

If security is enabled, a user of appropriate authority must be logged on before the system can be powered down.

1. Push the **POWER** button and hold it for three seconds.
2. Unplug the mains power supply.
3. Isolate the UPS batteries by setting the Battery Power switch to the '0' position.

Power up procedure

1. Ensure that the Battery Power switch is in the '0' position.
2. Plug in the mains power supply.
4. Set the Battery Power switch to the '1' position.
5. Push the `POWER` button.
6. Perform any required power-on security procedure.

Preparing the system unit

Before any add-ons can be installed, the system unit must be powered down and disconnected from the power supply, as described earlier. It must also be resting flat on the right side panel on a suitable work surface with the appropriate antistatic measures taken. As shown below:

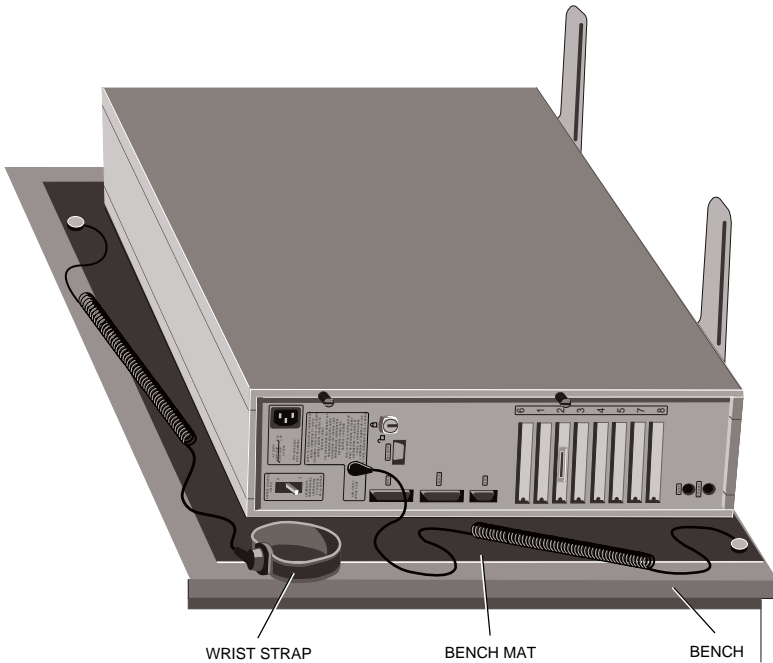

In the instructions that follow, it is assumed that the system unit is resting on a side panel and that the reader is viewing the system unit from the front, with the drive cradle door to the right.

Removing the side panel

To install any of the add-ons described here it is necessary to obtain access to the system board. This requires the removal of the left side panel as described below:

1. Prepare the system unit as described above.
2. Unlock the security lock on the rear panel.
3. Unscrew the two thumbscrews.

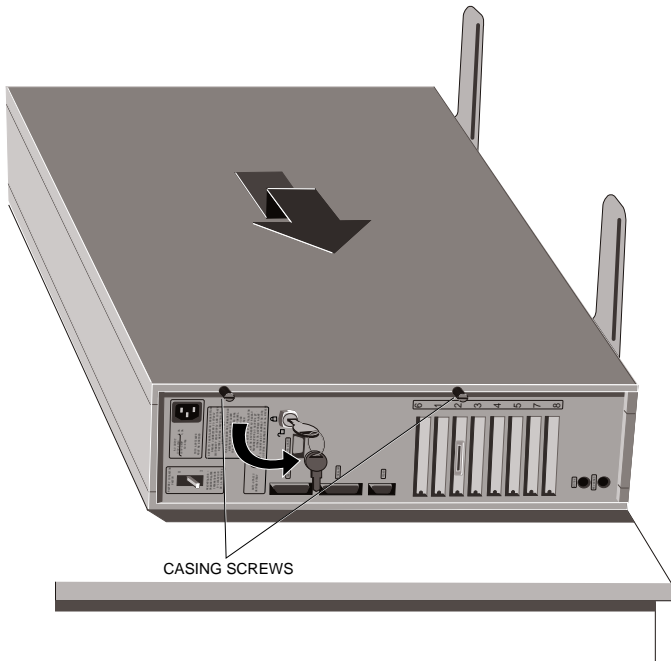

4. Slide the panel back about 15mm to free it from the lugs.
5. Lift the panel off.

Adapter cards

Eight 32-bit Micro Channel slots are available on the system board for adapter cards. Each slot has a blanking plate in the rear panel, and a notch in the adapter support metalwork at the front of the system unit.

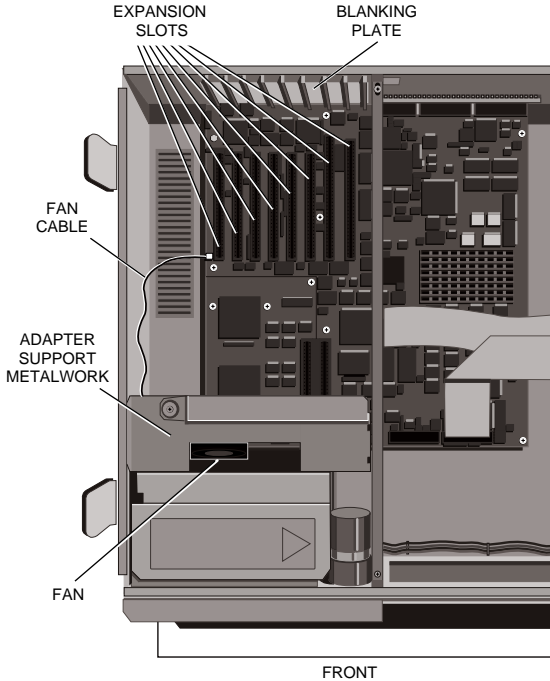

The two slots nearest the drive cradle (labelled 6 and 1) are both video slots. Slot 6 is suitable for use with video adapters that use only the Micro Channel Video Extension. Slot 1 is an XGA slot suitable for use with video adapters which conform to the IBM XGA standard, or with adapters that require the Micro Channel Matched Memory Extension.

Drive controllers must occupy slots 2 and 3. The primary controller always occupies slot 2 and the secondary (if fitted) slot 3.

It is recommended that slots 6 and 1 are left unoccupied (except for video cards), and slot 3 is left unoccupied (except for a secondary drive controller). Any other adapter cards should be fitted in slots 4, 5, 7 and 8 working down the system unit. Only after all these slots are full should cards other than video adapters or drive controllers be fitted in slots 6, 1 or 3.

To install an adapter card:

1. Remove the side panel as described in *Removing the side panel*.
2. Loosen the thumbscrew at the bottom of the blanking plate for the slot that the adapter is to occupy, and remove the blanking plate.

Note

If the thumbscrew is tight it may be necessary to use a screwdriver to release it.

3. Release the screw that secures the adapter securing bracket and swivel the bracket through 90°.

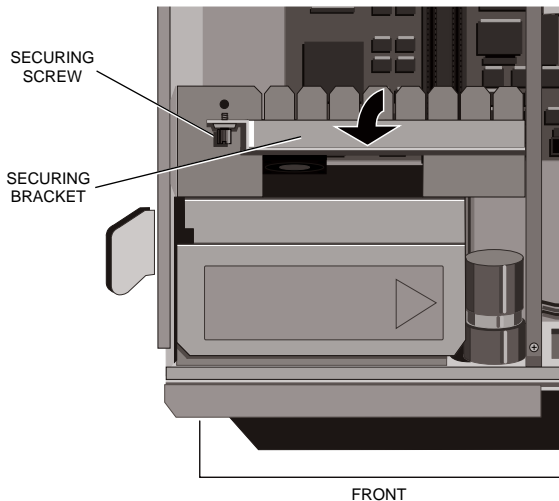

4. Holding the adapter card only by the plastic fixings, position it above the required connector. Make sure that the front edge of the card locates in the appropriate notch in the adapter support metalwork.
5. Using the plastic fixings, push the card firmly into the connector. Do not use excessive force.
6. Secure the card by tightening the thumbscrew at the bottom of the rear panel of the card.
7. Return the adapter securing bracket to its normal position and replace the securing screw.
8. Replace the side panel.
9. Power the system up and reconfigure for the new adapter.

Warning

Always ensure that the system unit is fully reassembled before powering it up.

Installing memory modules

A variety of memory configurations are possible in the Apricot FTe. Two different capacities of Single Inline Memory Modules (SIMMs) are available: 1 Mbyte and 2 Mbyte.

The following diagrams show the type of SIMM that should be fitted in each slot for each possible memory capacity. The memory sockets are labelled “MM1” to “MM8”, note that the sockets are not numbered in sequence.

4 Mb

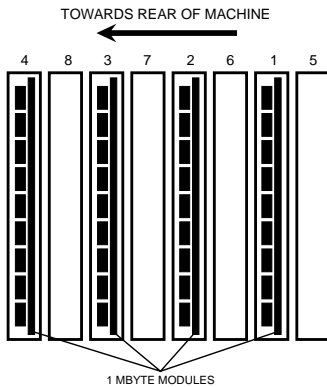

8 Mb

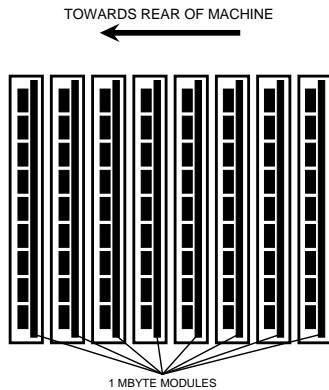

12 Mb

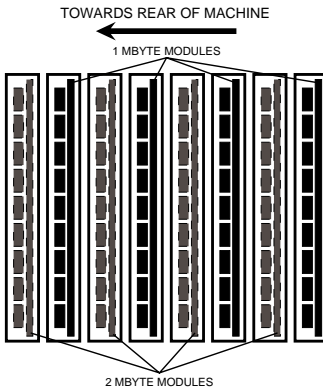

16 Mb

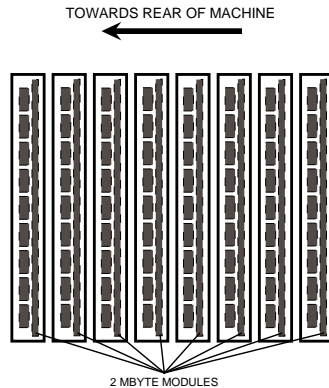

Obtaining access

To obtain access to the memory module sockets you must.

1. Remove the side panel as described in *Removing the side panel*.
2. Undo the four screws that secure the drive cradle.

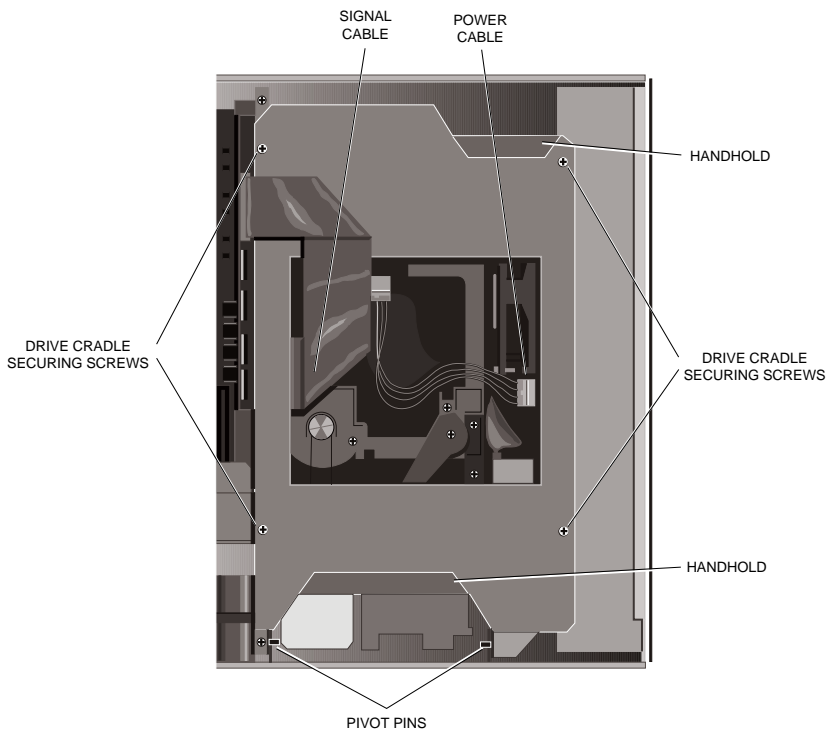

3. Disconnect the power cable(s) from the power supply, and the signal cable(s) from the connectors on the drive cradle.
4. Using the handholds provided at the front and rear of the drive cradle, lift the rear of cradle, swivelling it about the two pins at the front.
5. With the cradle at approximately 30° move it backwards to free it from the pins and lift it clear.

- Put the drive cradle down on a flat surface with the handholds uppermost.

Warnings

- Ensure that the drive cradle is stable.*
- The surface the drive cradle rests on must be flat. Any irregularity may come into contact with the drives in the cradle and damage them.*

Installation

If you are fitting additional SIMMs remove those already installed.

To remove a memory module:

- Insert a small screwdriver as shown in the following illustration and gently pull the latch at one side of the module forward.

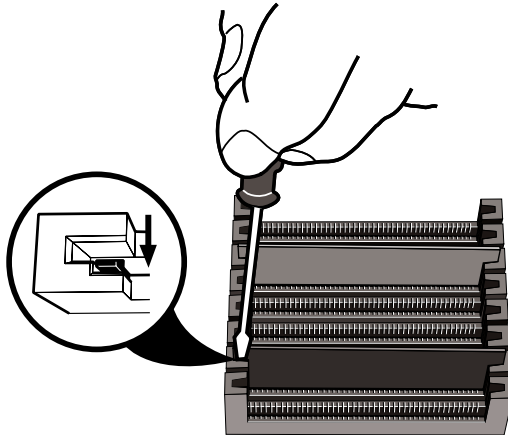

- Pull that side of the module 2 or 3 mm away from the system board.
- Repeat steps 1 and 2 for the other side of the module.
- Pull the module straight out of the slot, noting its slot position.
- Repeat steps 1 to 4 for all the memory modules, taking care to note the slot position of each.

From the illustrations showing the possible SIMM combinations decide which SIMM capacity will be installed in each slot. Then, working from the socket nearest the rear of the system unit towards the front, install the SIMMs.

To fit a SIMM:

1. Hold the SIMM so that the memory chips are facing the rear of the system unit with the metal connector strip nearest the system board.
2. Place the module in its correct socket and push it into position. Taking care not to exert undue pressure.

Once all the SIMMs are installed reset the memory configuration switches to the appropriate setting and reassemble the computer. There is a label inside the system unit identifying the switches and the appropriate positions.

Reboot your computer with the Reference diskette and reconfigure your system for the extra memory.

Warning

Always ensure that the system unit is fully reassembled before powering it up.

Co-processor

The 80486SX CPU module provides a socket for an 80487SX co-processor. To install the co-processor:

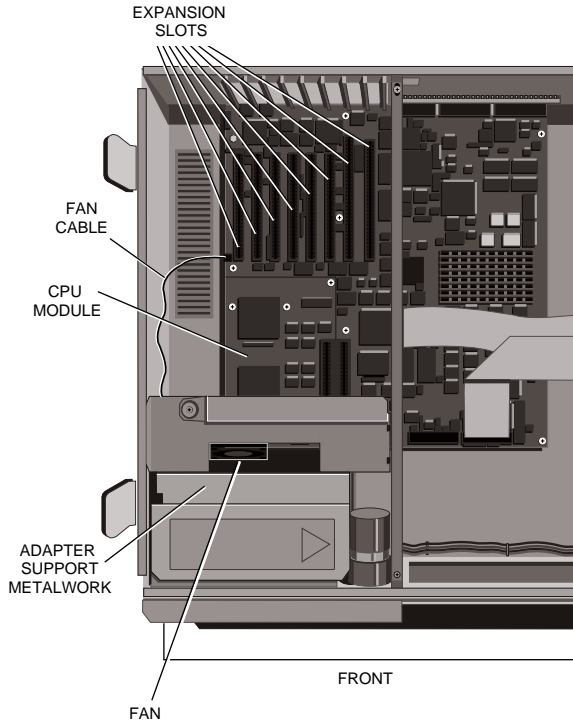

1. Remove the side panel as described in *Removing the side panel*.
2. Remove all adapter cards.
3. Identify the adapter support metalwork and fan from the illustration above.
4. Disconnect the fan's power cable from the system board.
5. Remove the two screws that secure the adapter support metalwork and lift the metalwork out.

6. Identify the 80487SX socket.

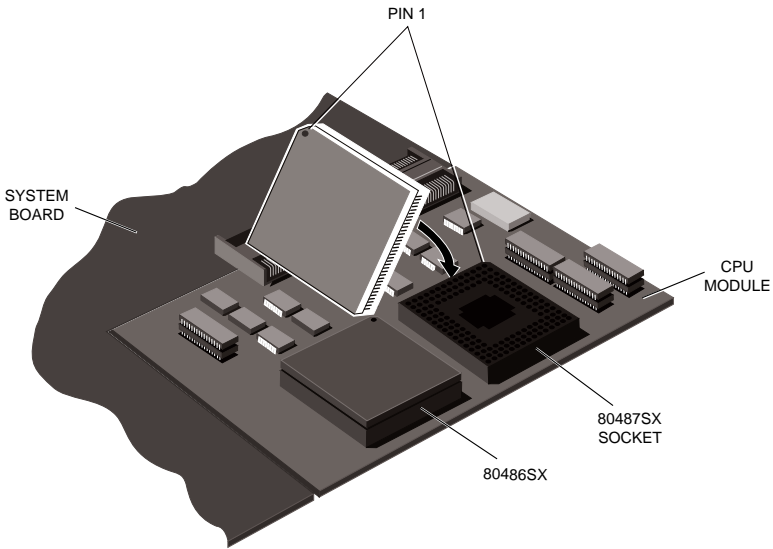

7. The 80487SX has a positioning guide in the form of a circular recess. Carefully position the 80487SX above the socket with the positioning guide at pin 1.
8. Gently insert the 80487SX making sure that it is correctly aligned with the socket and that you do not bend or otherwise damage the pins.
9. Reassemble the computer.

Note

Remember to reconnect the fan.

10. Reboot the computer with the Reference/SETUP diskette and reconfigure it for the co-processor.

Warning

Always ensure that the system unit is fully reassembled before powering it up.

Supplier upgrades

The add-ons described earlier may be installed by a confident and competent user. The installation of a CPU module upgrade, and additional (or replacement) drives is more complex, and should only be carried out by competent service personnel.

CPU module upgrade

If your Apricot FTe is fitted with an 80486SX CPU module it can be upgraded by fitting an 80486 CPU module. At the time of writing one 80486 CPU module is available, running at 33 MHz.

Higher performance CPU modules will be developed, and it will be possible to upgrade to these from either an 80486SX, or a 33 MHz 80486 CPU module. Contact your Apricot supplier for information about the availability of such modules.

Installing additional drives

The Apricot FTe provides a drive cradle that contains two bays with space for a maximum of five drives. These are:

- * Two 1/2 height drives at the front of the system unit.
- * Up to three SCSI hard disk drives at the rear of the system unit.

Notes

1. *The 3 1/2 inch floppy drive is not installed in the drive cradle. It is attached, via a mounting plate, to the power supply.*
2. *Drives available for the front bay include: 3 1/2 inch SCSI hard disk drives, 5 1/4 inch floppy drive, 5 1/4 inch SCSI tape drives. Any two of these may be fitted.*

Expansion options

The following table lists the possible upgrade routes for each possible combination of drives in each bay:

Drive bay	Current configuration	Possible expansion
Front	One 1/2 height drive	One 1/2 height drive or One 1" inch high drive
	One 1" high drive	One 1/2 height drive or One 1" inch high drive
Rear	One 1" high drive	One 1/2 height drive or One or two 1" inch high drives
	Two 1" high drives	One 1" inch high drive
	One 1/2 height drive	One 1/2 height drive or One 1" inch high drive

Note

The Apricot ESDI/SCSI hard disk controller supports a maximum of two SCSI hard disk drives. If you wish to use three or more hard disk drives, or a tape drive, you must install an Adaptec AHA1640 SCSI controller card.

Contact your Apricot supplier for further information about drive upgrades.

apricot

APRICOT COMPUTERS LIMITED
3500 PARKSIDE
BIRMINGHAM BUSINESS PARK
BIRMINGHAM B37 7YS.

 MITSUBISHI ELECTRIC

Part No 14829731
Revision 01