

8514-ULTRA™

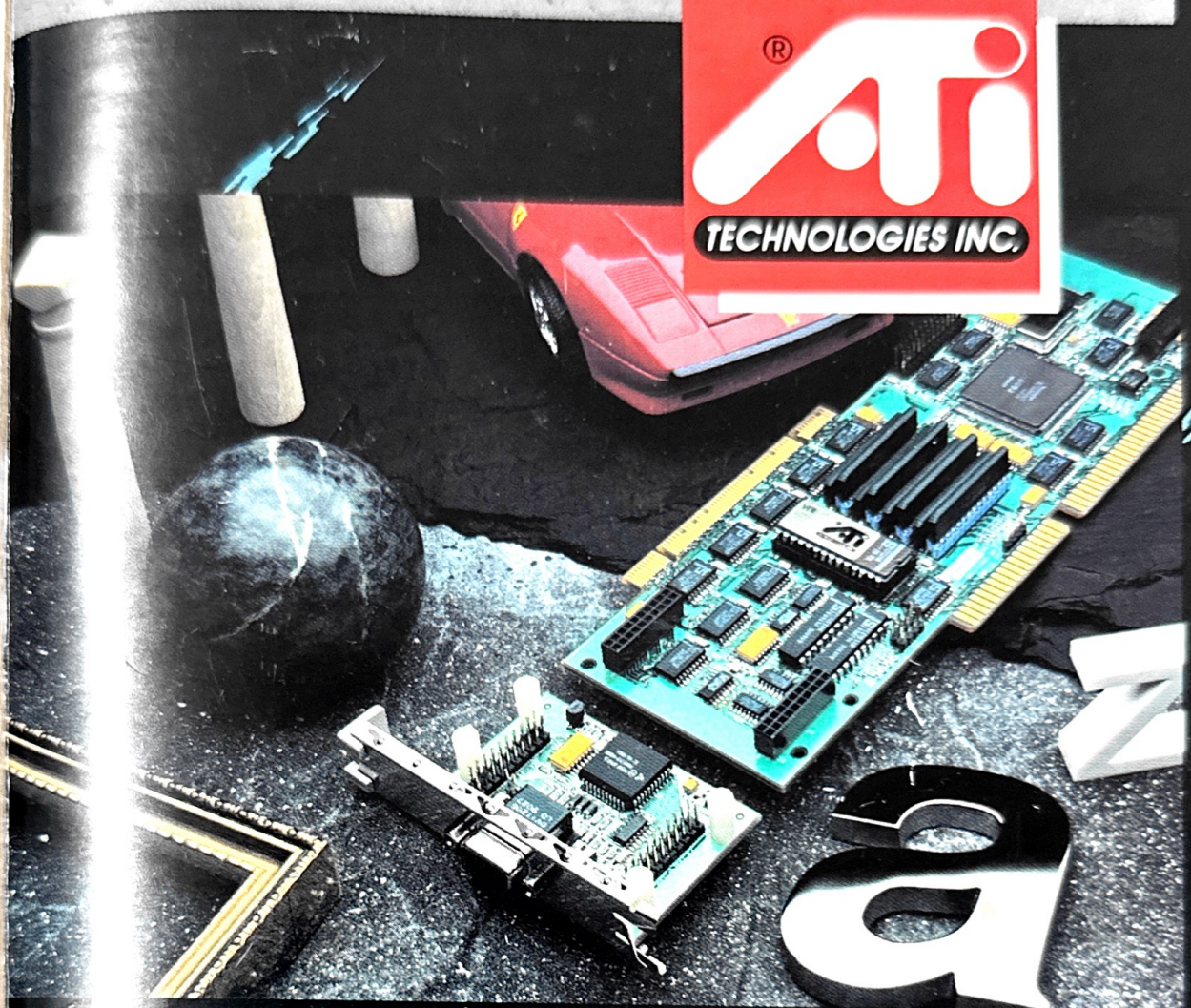

User's Guide

8514-ULTRA User's Guide

Version 2.1 - April, 1992 P/N: 10701F0103

ATI Technologies Inc. reserves the right to make changes to this document, and the products which it describes without notice. ATI shall not be liable for technical or editorial errors or omissions made herein; nor for incidental or consequential damages resulting from the furnishing, performance, or use of this material.

© Copyright 1991, by:
ATI Technologies Inc. Support: (416) 756-0711
3761 Victoria Park Avenue Office: (416) 756-0718
Scarborough, Ontario Fax: (416) 756-0720
Canada M1W 3S2 BBS: (416) 756-4591

ATI Technologies Inc. and Vibrant Graphics make no representation that the interconnection of products in the manner described herein will not infringe on existing or future patent rights, nor do the descriptions contained herein imply the granting of license to make, use or sell equipment constructed in accordance with this description.

All rights reserved, including those to reproduce this manual or parts thereof, in any form without the express written permission of ATI Technologies Inc.

Trademarks, registered or otherwise, used in this manual are: ATI, 8514-ULTRA, Mach 8, CRYSTAL Fonts, CRYSTAL Tune, VGAWONDER - ATI Technologies Inc.; Soft Engine/386 is a trademark of Vibrant Graphics, Ltd.; Postscript - Adobe; IBM, PC, PC/XT, PC/AT, PS/2, VGA, 8514/A, Courier, Micro Channel, XGA - International Business Machines; Windows, OS/2, Presentation Manager, Microsoft - Microsoft Corp.; MultiSync - NEC Home Electronics Inc.; Dutch, Swiss - Software Arts; VESA - Video Electronics Standards Association; AutoCAD, AutoSHADE, 3D Studio - Autodesk Inc.; Facelift - Bitstream; LHARC - H. Yoshizaki.

FCC Compliance Statement

Warning

Changes or modifications to this unit not expressly approved by the party responsible for compliance could void the user's authority to operate this equipment.

Note

This device complies with Part 15 of FCC Rules. Operation is subject to the following two conditions:

- (1) this device may not cause harmful interference, and
 - (2) this device must accept any interference received, including interference that may cause undesired operation.
-

This equipment has been tested and found to comply with the limits for a Class B digital device, pursuant to Part 15 of the FCC Rules. These limits are designed to provide reasonable protection against harmful interference in a residential installation. This equipment generates, uses and can radiate radio frequency energy and, if not installed and used in accordance with manufacturer's instructions, may cause harmful interference to radio communications.

However, there is no guarantee that interference will not occur in a particular installation. If this equipment does cause harmful interference to radio or television reception, which can be determined by turning the equipment off and on, the user is encouraged to try to correct the interference by one or more of the following measures:

- Re-orient or relocate the receiving antenna.
 - Increase the separation between the equipment and receiver.
 - Connect the equipment into an outlet on a circuit different from that to which the receiver is connected.
 - Consult the dealer or an experienced radio/TV technician for help.
-

Warning

The use of shielded cables for connection of the monitor to the card is required to assure compliance with FCC regulations.

DOC Compliance Statement

This digital apparatus does not exceed the class B limits for radio noise emissions from digital apparatus set out in the Radio Interference Regulations of the Canadian Department of Communications.

MDC Avis De Conformation

Le présent appareil numérique n'émet pas de bruits radioélectriques dépassant les limites applicables aux appareils numériques de Classe B prescrites dans le Règlement sur le brouillage radioélectriques édicté par le ministère des Communications du Canada.

Table Of Contents

	Page
FCC and DOC Compliance Statement	
1. 8514-ULTRA	1
Introduction	1
Features.....	1
How to Use this Guide	3
2. Contents of the Package	5
8514-ULTRA Block Diagram	6
Jumper Information	7
3. The Mach 8 Video Controller	8
4. Monitor Selection	9
Automatic Monitor Detection	9
Setting Refresh Rates to Reduce Flicker.....	10
5. Installing on ISA/EISA Computers	11
6. Installing on Micro Channel Computers	15
7. Configuring the 8514-ULTRA	20
Getting Started	20
Configuring the 8514-ULTRA	21
Configuration Options	23
Storing the Configuration	24
Uninstall Graphics Adapter	25
8. Software Utilities	26
Procedure	26
9. CRYSTAL Fonts	27
Installation Procedure	29
10. ATI Device Drivers	30
Main Procedure	30
AutoCAD Procedure	31
Installing the AutoCAD (Real Mode) Driver	31
Using the Display List	33
Presentation Manager for OS/2 Procedure	35
Windows 3.x Procedure	36

11. The ATI Turbo Adapter Interface	39
Installing HDILOAD.EXE for DOS	40
How to Load and Unload ATI Turbo AI	40
Installing the ATI Turbo AI for OS/2	41
12. Soft Engine/386 for AutoCAD 386	42
Introduction	42
System Requirements	43
Before Installing Soft Engine/386	43
Installation	44
Configuration for AutoCAD	45
Usage with AutoCAD	49
Suggested Button Configurations	56
International Usage	57
Appendix A	58
Troubleshooting and Diagnostics	58
INSTALL - Test Graphics Adapter	60
Troubleshooting	61
Using CRYSTAL Fonts with Specific Applications	64
Customer Support Form	64
Appendix B	67
Memory Upgrades	67
Procedure	67
Appendix C	68
Custom Monitor Configuration	68
Determining Resolution and Refresh Rates	68
Adjusting Screen Size	69
Specifications	71
Hardware Warranty	73
Warranty Card	
CRYSTAL Font Converter Coupon	

8514-ULTRA



Introduction

Congratulations on your purchase of the award-winning **8514-ULTRA**. You are in possession of one of the most advanced and most versatile graphics controllers available for personal computers today.

The **8514-ULTRA** will transform your PC into a powerful graphics workstation. Its high performance graphics coprocessor and 16-bit design will accelerate your graphics applications such as CAD, DTP, Windows and Presentation Manager.

With your **8514-ULTRA**, you will be working in a totally new graphical environment: screen resolutions up to 1280x1024 (1.0MB version only); flicker-free refresh rates up to 76Hz at 1024x768; realistically shaped and positioned fonts where characters as small as 6 point can be read effortlessly on a 14" display; and unparalleled graphics speed that prompted PC Magazine to call the **8514-ULTRA** "the card to beat"¹.

Features

High Performance Graphics Coprocessor

- A highly optimized graphics coprocessor provides workstation graphics performance on IBM AT/386/486 compatible and Micro Channel computers.
- Accelerated modes in 640x480, 800x600, 1024x768 in 16 or 256 colors, and 1280x1024 in 16 colors using appropriate drivers (8514/A, 8514-AI, and ATI Windows, AutoCAD, and Presentation Manager drivers).

1024x768 and 1280x1024 Graphics Modes

- Displays interlaced or non-interlaced 1024x768 graphics on suitable monitors in 16 or 256 colors, and interlaced 1280x1024 (1.0MB version only) in 16 colors.

- Provides superior flicker-free graphics. With its 60, 70, 72 and 76Hz ergonomic vertical refresh rates, screen flicker is virtually eliminated, reducing eyestrain and increasing productivity.

100% Register Level Compatibility with IBM 8514/A Standard

- The **8514-ULTRA** supports any application written to the 8514/A standard - whether programmed directly to the registers or through the software Adapter Interface (AI).

ATI CRYSTAL Fonts

- Uses proprietary anti-aliasing font technology to displays screen fonts with laser printer quality. Provides scalable, true WYSIWYG screen fonts, accurate in size, shape and position.
- Provides laser quality 300dpi screen fonts on conventional 1024x768 (96dpi) monitors. CRYSTAL Fonts is an unparalleled screen technology that creates the truest font shapes and positioning ever, giving you the most accurate screen representation of how your printed document will look. Your **8514-ULTRA** includes CRYSTAL Fonts drivers for 1024x768 and 1280x1024 screen resolutions.
- Scales to any size, offering you the advantages of:
 - Convenience:** no need to generate fonts for each individual size;
 - Disk Space:** uses 85% less disk space than a set of bit-mapped fonts;
 - Speed:** uses the ATI Mach 8 coprocessor to generate fonts in real time: no more waiting for screen fonts to be pre-generated; display as many different fonts as you wish!
- Includes 13 CRYSTAL Fonts for Windows in PostScript styles (Swiss, Dutch, Courier and Symbol in different weights), and CRYSTAL Tune, a utility that allows you to customize your CRYSTAL Fonts display.

Advanced Software Drivers

- Includes specialized drivers for AutoCAD, Windows and Presentation Manager that have enhanced support for the coprocessor's additional performance and features.
- High Speed Turbo AI (Adapter Interface) for DOS and OS/2 provides software support for applications which use the 8514-AI.

Dual Bus Architecture

- Supports both Micro Channel and Industry Standard Architecture (ISA) or AT bus on a single card. Toolkit included.

VGA Pass-Through Connector

- Supports VGA pass-through (VESA² specification) for single monitor operation. Cable included.

Advanced VLSI Gate Array Technology

- Built around the exclusive ATI Mach 8 graphics coprocessor, the **8514-ULTRA** features low power consumption, high speed performance, and complete reliability, all at an incredibly affordable price.

Available in 512K or 1.0MB Versions

- The **8514-ULTRA** comes with either 512K or 1.0MB of coprocessor memory. 512K versions can be expanded to 1.0MB (see Appendix B) to support more colors and 1280x1024 modes.

Warranty

- All ATI products come with a five (5) year limited warranty.

How To Use This Guide

1. Refer to the README file on disk #1 for the latest information.
2. To install graphics card in an AT (ISA) bus computer, refer to Chapter 5. To install in an MCA bus computer, refer to Chapter 6.
3. To install the utilities and software drivers, refer to Chapters 7 through 12 to ensure correct configuration and optimum performance.

Command Syntax

When prompted to use the utilities in this guide, the following conventions are used:

Example:	C:\COMMAND [option] [keyword]
C:\	Refers to the DOS command prompt.
COMMAND	Is an executable file (i.e. INSTALL).
[keyword]	Denotes and optional keyword.
[option]	Denotes an optional argument or condition.
<enter>	Press the key inside the bracket.

README Files

On Disk #1 is a README file containing notes on the latest revisions. In addition, there is a README.XXX file in each driver subdirectory containing specific instructions for each driver.

To examine the README[.XXX] files, at the DOS prompt type:
A:\TYPE [README.XXX] <enter>
or use a word processor to print this file.

Contents of the Package

2

Your **8514•ULTRA** package includes the following:

- **8514•ULTRA** Adapter.
- User's Guide.
- ISA-style retaining bracket assembly.
- Micro Channel retaining bracket and card-guide extension.
- Four (4) Utility disks (2 high density 5.25" and 2 high density 3.5" format).
- VGA Pass-through cable.
- VGA terminator plug.
- Toolkit.

Be sure to make working copies of the original disks to prevent loss of important files due to accidental erasure.

To make a backup copy of the disks, use the following procedure:

1. Obtain a blank formatted disk in the media type you intend to use.
2. Insert the disk in drive A.
3. Type the DOS command:
`DISKCOPY A: A: <enter>`
4. When prompted for your **SOURCE** disk, insert the first **8514•ULTRA** disk.
5. When prompted for your **TARGET** disk, insert the blank disk.
6. Repeat procedure for second **8514•ULTRA** Utilities disk.
7. Ensure that new disks are properly labelled.

Note

To validate your Warranty and have access to Customer Support Services, you must complete the Warranty Card at the back of this guide.

8514-ULTRA Block Diagram

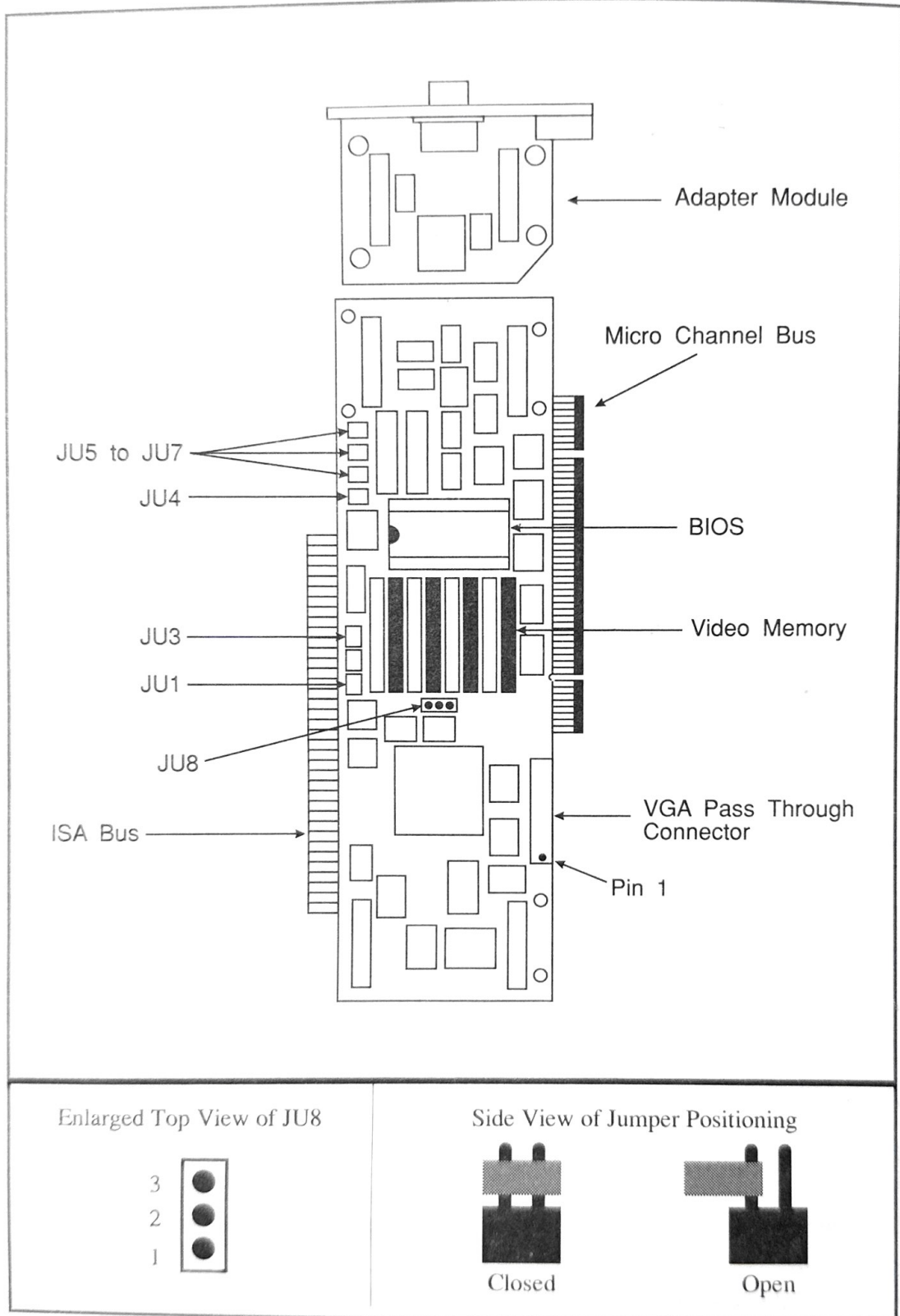

The following table describes the jumpers on the **8514-ULTRA**. Refer to Appendix A for further information. **DO NOT** change the jumper settings unless necessary.

Jumper Information

EEPROM	JU1
Disable	1, 2
Enable	2, 3*

Memory Size	JU3
512K	On
1.0MB	Off

I/O	JU4
8-bit	2, 3
16-bit	1, 2*

IRQ**	INSTALL
2	JU5
3	JU6
5	JU7

Pixel Clock	JU8
Clock	1, 2
Clock Bar	2, 3*

* Factory Default ** The IRQ (Interrupt Request) level on the **8514-ULTRA** is not used by any known software. These jumpers have been provided for possible future considerations. The factory default is set for all interrupts disabled.

The Mach 8 Video Controller

3

The **8514-ULTRA** uses the ATI Mach 8 Coprocessor Controller. The Mach 8 coprocessor controller accelerates graphics programs by transferring graphics computations from the system's CPU directly to the graphics card. This frees up the computer's processor to perform other functions and minimizes data movement across the system bus, a common bottleneck to overall performance.

The Mach 8 coprocessor controller is not activated until called upon by a graphics driver. Software drivers that directly address the Mach 8 coprocessor on the **8514-ULTRA** include:

- Standard 8514/A drivers available with most software packages.
- Mach 8 **8514-ULTRA** drivers written by ATI or other software vendors.
- Applications writing to the IBM 8514-AI (Software Adapter Interface).

The coprocessor memory can be either 512K or 1.0MB in size. The additional memory will support more colors and resolutions as shown below:

Resolution/Color Support in Coprocessor Mode

Resolution	Colors with 512K	Colors with 1.0MB
1280x1024	N/A	16
1024x768	16	256
800x600	16	256
640x480	16	256

The Mach 8 coprocessor controller will support all vertical refresh rates independent of memory size.

For the best performance, reconfigure your graphics programs to use the coprocessor controller by specifying either an 8514/A adapter or using the Mach 8 drivers provided with the **8514-ULTRA**.

Monitor Selection

4

Selecting the appropriate monitor will ensure the best combination of resolution and refresh rate support. This chapter describes the monitor types supported by the **8514-ULTRA**.

Automatic Monitor Detection

The **8514-ULTRA** uses automatic monitor detection to configure the card for the type of monitor being used. The monitor must be powered up before the computer system is turned on, or an incorrect monitor type may be detected. The **8514-ULTRA** comes preconfigured for the IBM 8514 monitor specification. If at the time the computer was turned on and no monitor was detected during initial installation (either not connected, not properly connected or not powered on), the **8514-ULTRA** will default to a monochrome VGA monitor setting.

Warning

Do not change monitors or connect a monitor (if one is not attached) when your computer is on. Serious damage can result to the monitor.

Use the **INSTALL** program (refer to Chapter 7) to permanently change the monitor selection, optimize the card to your monitor, and save the selection. The following section describes the monitors that can be used with the **8514-ULTRA** and what modes are supported on those monitors.

VGA/Analog Monitors (31.5kHz) or PS/2 Displays

VGA/Analog monitors will support the following modes:

- VGA, EGA, CGA, MDA, Hercules, 80 and 132 column text modes.
- 640x480 in 16 or 256 color modes.

IBM 8514/8515 (43.5 kHz) or Compatibles

The IBM 8514/8515 monitors are high resolution analog color monitors, and in addition to the modes listed above will support the following modes:

- 1024x768 in 16 or 256 colors interlaced.

MultiSync Or Multifrequency Monitors

MultiSync monitors will operate at a range of frequencies and will provide the widest graphics support. Multifrequency monitors operate at specific frequencies over a given bandwidth. Refer to the Operating Manual of your monitor to see which modes it will support, or call your dealer to obtain the necessary cables and adapters if required. Move the signal switch (if applicable) on your monitor to ANALOG.

Most MultiSync/Multifrequency monitors will support the modes listed above as well as the following:

- 800x600 in 16 or 256 colors.
- 1024x768 in 16 or 256 colors non-interlaced.
- 1280x1024 in 16 colors interlaced¹.

Your monitor must be able to support the appropriate horizontal and vertical frequencies to display these high resolution modes. Check the **8514•ULTRA** specifications section for signal compatibility with your monitor. See Chapter 7 for more details.

Setting Refresh Rates to Reduce Flicker

In addition to the high resolution modes supported, the **8514•ULTRA** supports different vertical refresh rates of up to 76Hz at resolutions from 640x480 to 1024x768. Choosing a 70, 72 or 76Hz refresh rate will update the visual information on your screen that many times per second. A higher refresh rate means less flicker and therefore reduced eyestrain. A non-interlaced 60Hz and 66Hz refresh is also supported.

The resolution of your software application program is independent of the refresh rate. The refresh rate depends on the monitor selected during the installation process in INSTALL (see Chapter 7), while the resolution depends on the software driver installed (see Chapter 10).

You can create a custom monitor configuration as outlined in Appendix C. If you notice a slight decrease in performance when using the higher refresh rates, set the card to 60Hz operation.

¹ Check bandwidth specifications of your monitor with the specifications at the back of this guide

Installing on ISA/EISA Computers

5

This section describes how to install the **8514-ULTRA** on machines with an ISA (Industry Standard Architecture) or EISA (Extended Industry Standard Architecture) bus. AT compatible computers have ISA bus slots. IBM PS/2 Computers except for the Model 30, have Micro Channel bus slots. If you are using a Micro Channel computer, refer to Chapter 6.

Warning

If you have previously installed the **8514-ULTRA**, you must use the UNINSTALL option in the INSTALL program before moving the card to a different system. This step is necessary to prevent conflicts between the **8514-ULTRA** boot ROM and other adapter ROM or RAM when installing into a new system. This step is particularly necessary when moving the **8514-ULTRA** between Micro Channel and ISA machines, or vice-versa.

The **8514-ULTRA** is designed for use in any 8- or 16-bit expansion slot in an IBM or compatible machine, or in the IBM Personal System/2 Model 25 and 30. You must use a VGA controller with the **8514-ULTRA** to boot the card.

Note

Static electricity can seriously damage the components in your computer. You must ensure that you have discharged any static electricity by grounding yourself to the chassis of the PC before you begin.

The **8514-ULTRA** comes factory installed for ISA computers. If you have removed the Adapter module, use the instructions in Step 1 for reassembly.

1. Mount the module assembly on the **8514-ULTRA** adapter as shown in the following diagram. Make sure that the module is

placed on the connector on the side of the AT bus with the notch facing away from the AT bus. The AT bus connector can be identified as the two gold fingers on the bottom of the card. The **8514-ULTRA** is shipped with the module installed for ISA bus computers. Fasten it with the four plastic screws.

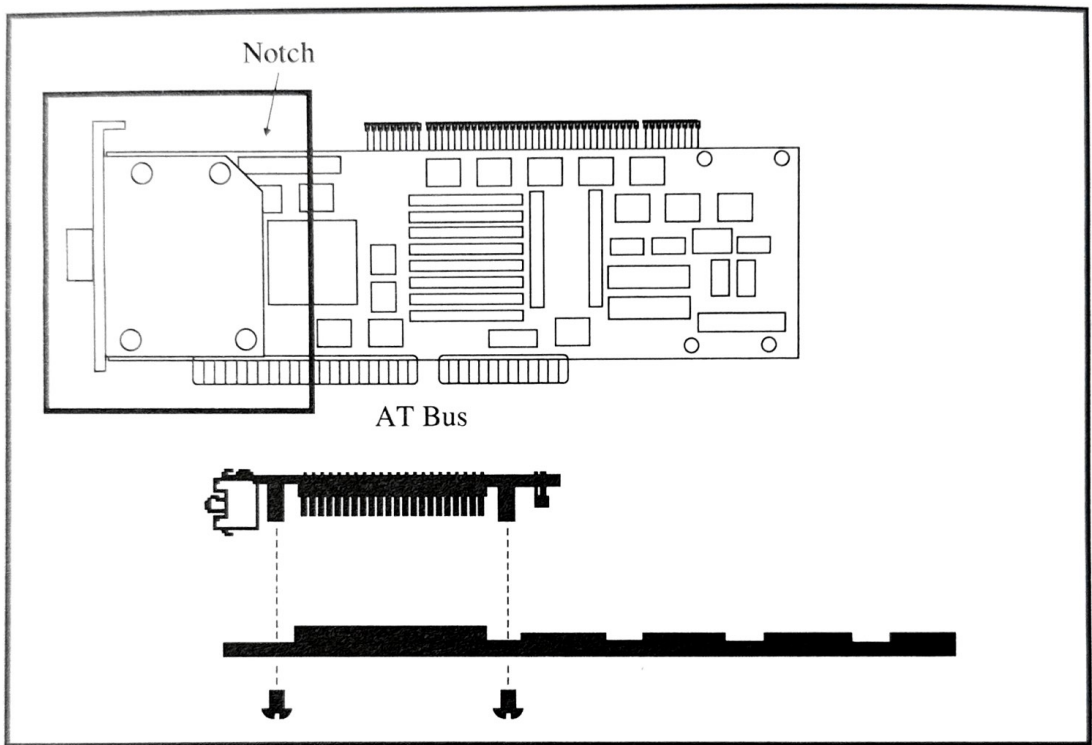

2. Ensure that the system is switched off and the power cord removed before proceeding. Damage to the **8514-ULTRA** and the system may result if the power is left on during installation.
3. Follow the manufacturer's instructions for the removal of the system unit cover from your computer.

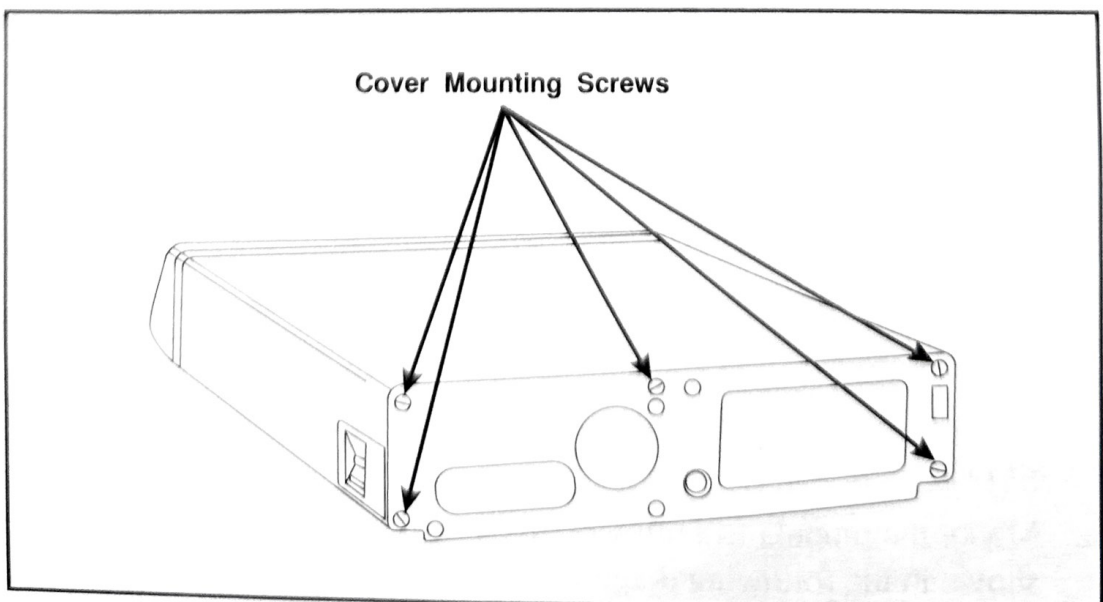

4. Select an empty slot adjacent to the computer's VGA card, if applicable. If you are using a single monitor, the **8514•ULTRA** must be installed in a slot either in front of, or immediately behind the VGA card. You may have to rearrange other cards in your system to free up a slot next to the VGA card.

If your system has VGA built into the motherboard, select the slot closest to the VGA Feature Connector on the mother board.

You may need to refer to your Computer System User's Manual to locate the motherboard VGA Feature Connector.

5. Remove the slot cover at the rear of the system. Grasping the card by the top left edge, firmly seat it into the expansion slot as shown in the diagram. Insert the screw from the expansion slot cover in the hole at the top of the **8514•ULTRA**'s retaining bracket and tighten it.

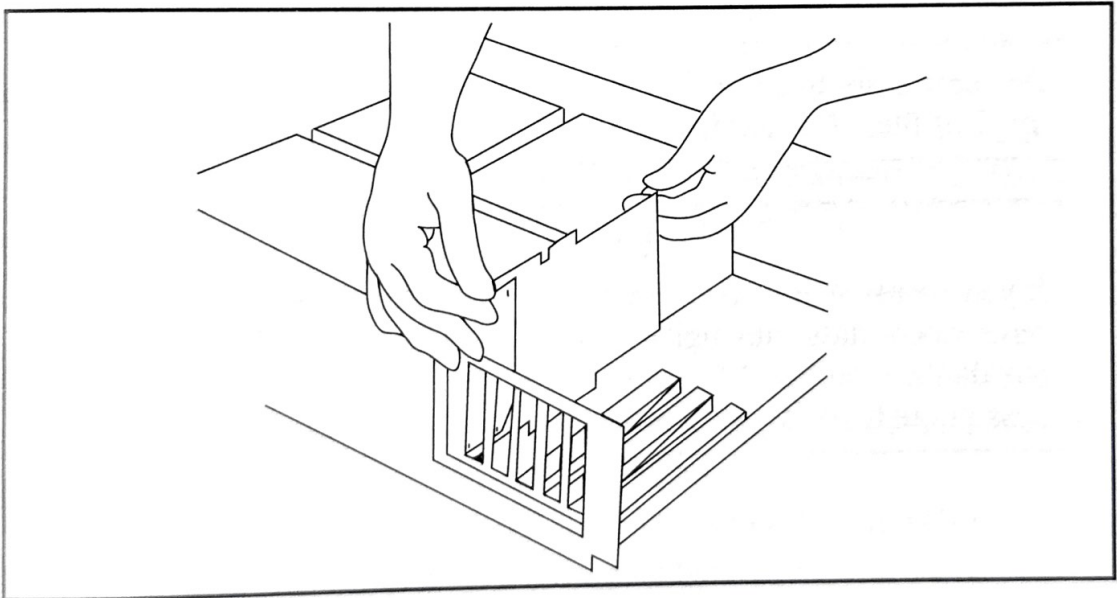

Note

For the best results, insert the **8514•ULTRA** into a 16-bit slot. A 16-bit slot will accommodate both of the gold connectors located on the bottom of the **8514•ULTRA**.

6. If you are running a single monitor, connect one end of the pass-through cable to the stake header connector on the **8514•ULTRA** and the other end to the gold-edged Feature Connector on the top of the VGA card,

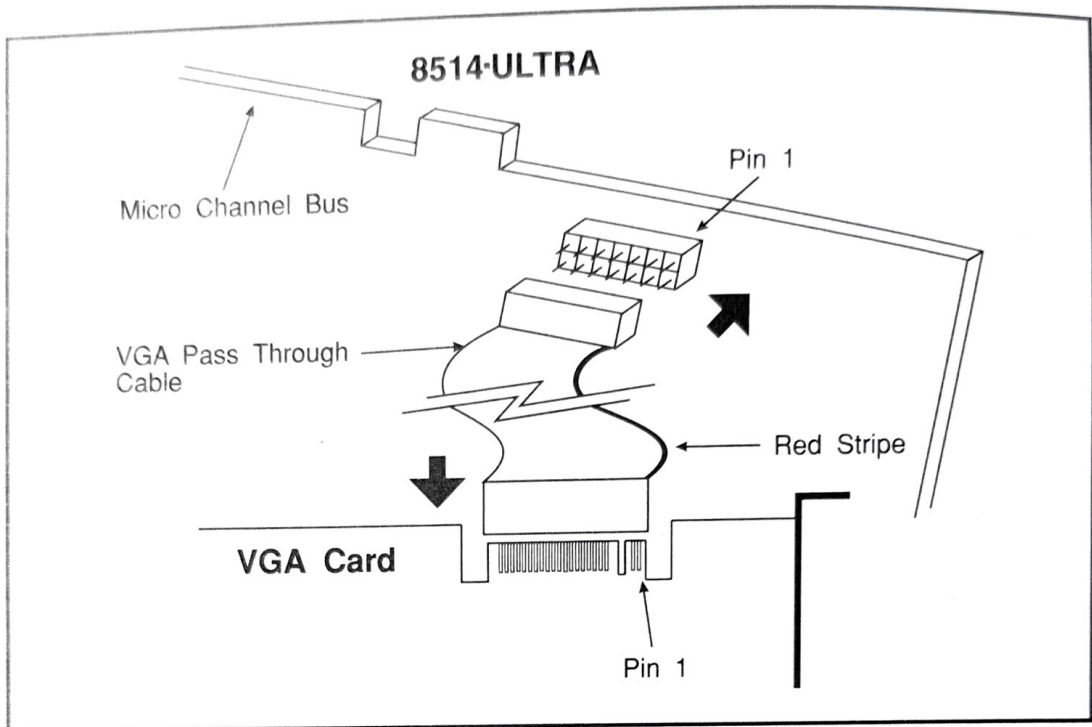

Note

Be careful not to twist the cable. The cable must be attached to pin 1 of the VGA card and the **8514-ULTRA** as shown above.

Warning

If you are using the VGA Pass-through with the VGAWONDER or other video cards with digital monitor support, **DO NOT** connect to any digital monitors (EGA, CGA, TTL Monochrome) if running in pass-through mode, as serious damage could result to the monitor.

If the Feature Connector on your VGA or motherboard is a stake header connector instead of a gold-edged connector, use the appropriate connector on the cable.

If you are using a single monitor, plug the monitor cable into the **8514-ULTRA**. Connect the VGA terminator plug into the DB-15 port on your VGA card. If you are using a dual monitor system, plug the VGA monitor cable into the VGA card. Plug the cable from the high-resolution monitor into the **8514-ULTRA**. Do not use the pass through cable.

7. Replace the system unit cover and tighten the screws.
8. Before using your **8514-ULTRA**, you must first configure the card. Refer to the INSTALL.EXE program supplied on the **8514-ULTRA** disk (see Chapter 7).

Installing on Micro Channel Computers



This section describes how to install the **8514-ULTRA** graphics card into computers with a Micro Channel bus. If you are using a computer with an AT (ISA) bus, refer to Chapter 5.

Note

You must alter the board in order to use it in a Micro Channel bus.

Note

Static electricity can seriously damage the components in your computer. You must ensure that you have discharged any static electricity by grounding yourself to the chassis of the PC before you begin.

1. Locate the following parts included with the **8514-ULTRA** for the installation into a Micro Channel computer:
 - Bracket
 - Plastic Clip
 - Bolt
 - MC Tool

Using the tools provided by ATI, remove the 4 screws on the back side of the Adapter Module (the white screws on the back of the board) and remove the nuts holding the existing bracket. Install the parts as shown in the diagram on the following page, fastening the plastic clip first. Slide the 3 prong end of the Micro Channel bracket into the plastic clip and then tighten the nuts.

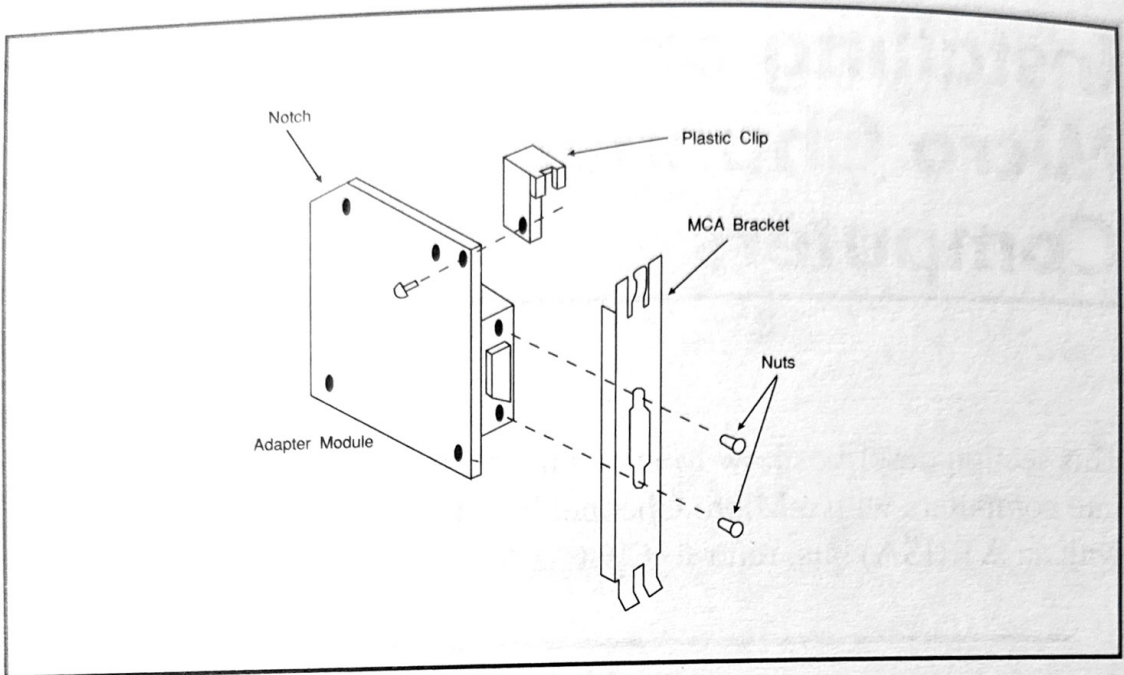

2. Mount the module with the Micro Channel retaining bracket on the **8514-ULTRA** as shown in the diagram below. Fasten the retaining bracket onto the **8514-ULTRA** using the four plastic screws. Make sure that the notch on the module is facing up (away from the MCA bus connector).

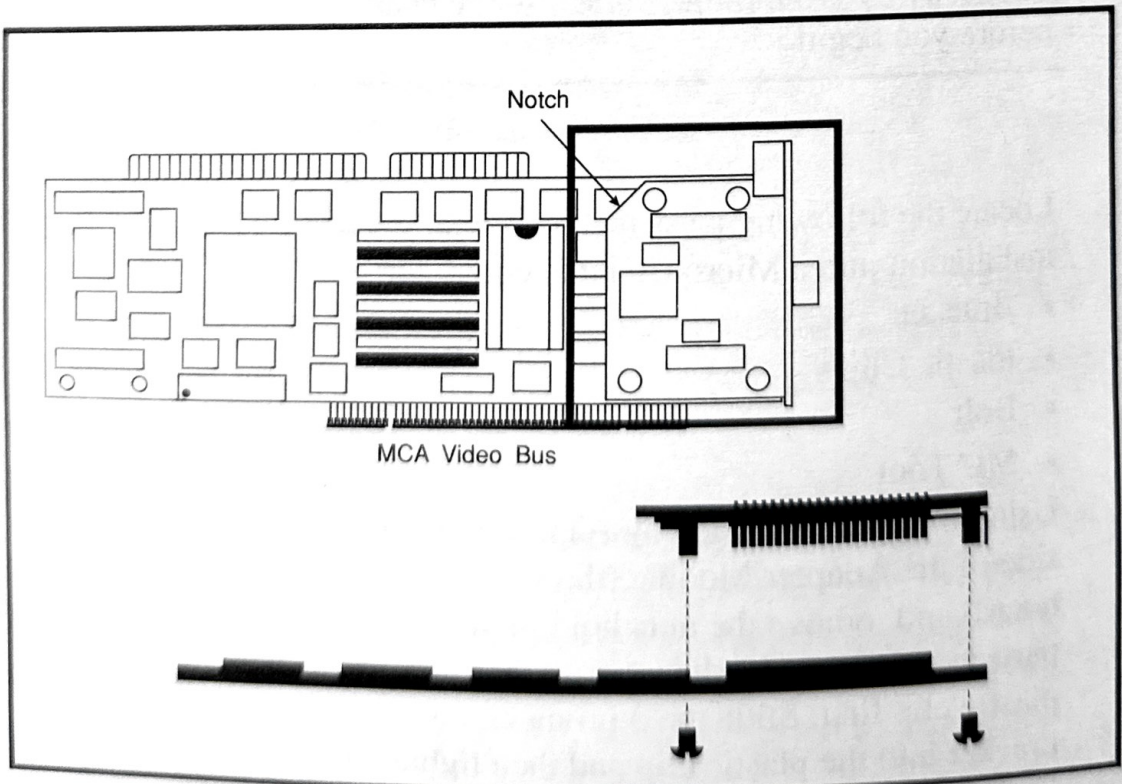

3. Ensure that the system is switched off and that the power cord is removed before proceeding. Damage to the **8514-ULTRA** and the computer system may result if the power is left on.

4. Follow the manufacturer's instructions for the removal of the system unit cover.
5. The **8514-ULTRA** must be installed in slot 1 of Micro Channel computers. This bus slot contains additional connectors for the Video Bus which is used by the **8514-ULTRA** to pass VGA signals to the monitor connected to the **8514-ULTRA**.

Slot 1 may be identified by the additional connectors for the video bus. If an adapter is already installed in slot 1, move that card to a different slot.

6. Remove the slot cover at the rear of the system by loosening the retaining screw, and pulling upward gently.

Install the **8514-ULTRA** into the empty expansion slot. Grasping the card by the top left edge, firmly seat it into the expansion slot as shown below.

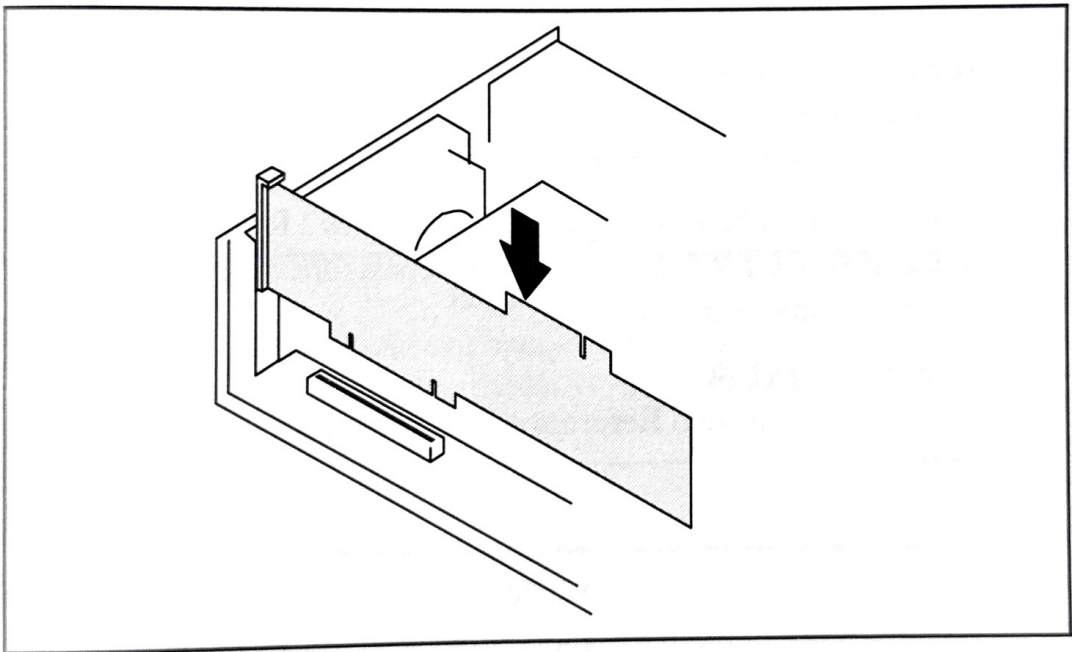

Gently retighten the retaining bracket screw at the bottom of the adapter cover opening.

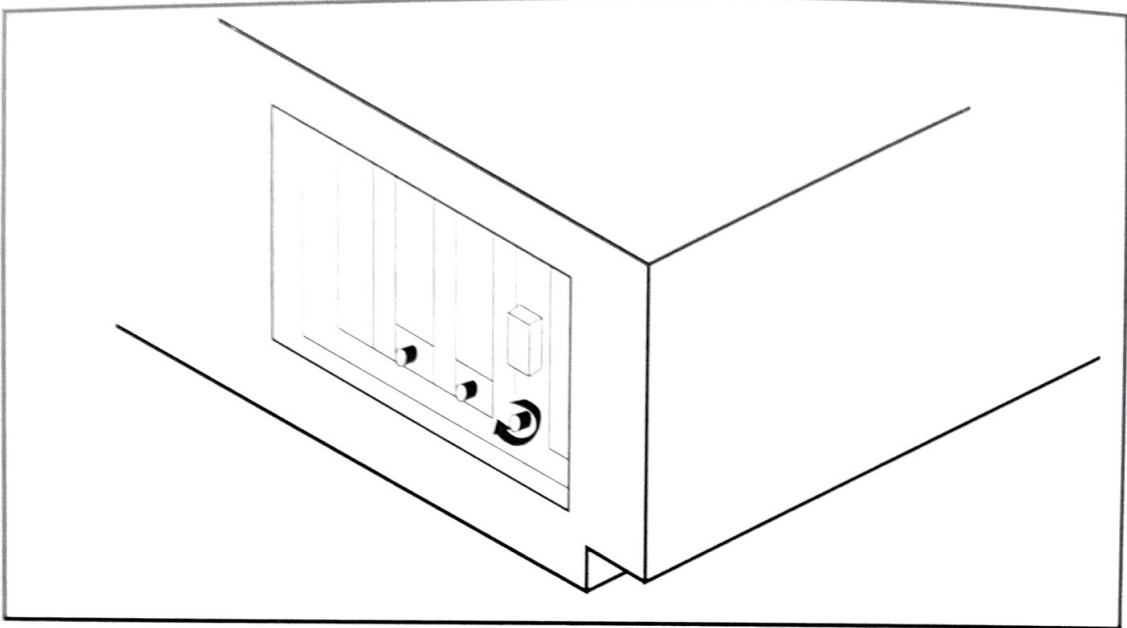

7. Replace the system unit cover, and fasten the screws.
8. If you are using a single monitor, plug the monitor cable into the **8514•ULTRA**. If you are using two monitors, plug the high resolution monitor into the **8514•ULTRA** and the other monitor cable into the lower video port on the PS/2 computer.
9. The system must be reconfigured using the PS/2 Reference Disk and the **8514•ULTRA** Utility Disk. To configure the system, refer to the following instructions:
 - a) **Reference Disk**
Insert your system **Reference Disk** into drive A and turn on the system.

Note

You must reconfigure the computer using the Reference Disk even if your system is configured for the IBM 8514/A card. Use the most recent backup copy of the Reference Disk to avoid unnecessary complications. Refer to your System Reference Manual for further information.

b) Error Messages

Your system will report error 165 and beep twice. Press <enter> after the IBM logo appears. Press <PgDn> until the following message appears on-screen:

"Automatically Configure System (Y/N)"

Select <N> for No and the next screen will appear.

c) Option Disk

Select the option:

"3. Copy an Option disk"

and insert your **8514•ULTRA** Utility Disk into drive A. If you have a single disk drive, you will need to swap the disk several times to copy it. When the duplication procedure is complete, leave the Reference Disk in drive A and press <enter>.

d) Configuration

Select the option:

"3. Set Configuration"

then select:

"5. Run Automatic Configuration"

and press <enter>.

When the configuration process is completed, press <esc> and then <enter> to restart the system. Remove the updated Reference Disk. Continue with the INSTALL process in Chapter 7.

Important

The **8514•ULTRA** will not operate correctly unless the adapter has been configured using the INSTALL procedure outlined in Chapter 7.

Configuring the 8514•ULTRA

7

The INSTALL.EXE program will perform various installation and testing functions. The first screen in the program is “Main Selection Menu”. It is the starting point for the following functions:

- Setting the graphics card to power up according to your system configuration (Chapter 7).
- Installing the **8514•ULTRA**’s software utilities (Chapter 8).
- Installing CRYSTAL Fonts (Chapter 9).
- Installing screen drivers for applications (Chapter 10 and 12).
- Installing the Turbo Adapter Interface (Chapter 11).
- Testing Mach 8 coprocessor video modes (Appendix A).

Getting Started

The keys listed below are used to move around in the menu system and edit parameters. At any time during the configuration procedure, the activated keys and their functions are listed at the bottom of your screen.

- | | |
|----------------|--|
| <F1> | - is the context sensitive HELP key. Press it anytime for information on the highlighted topic or menu item. All valid parameters for that item will be found in the HELP screen where applicable. |
| <up> <down> | - are movement keys. The highlight or cursor is moved by these keys in the indicated direction. |
| <left> <right> | - are movement keys. These keys move the highlight or cursor to the beginning or end of a menu or selected item. |
| | - deletes the character sitting on the cursor. |
| <backspace> | - deletes the character to the left of the cursor. |
| <shift> +<F7> | - writes factory default values to the 8514•ULTRA EEPROM. |
| <enter> | - depending upon your position in the menu, this key will: a) display a lower level menu; b) display a list of parameters to choose; c) accept the highlighted parameter. |

- <F10> - saves all current changes in the selected menu.
- <esc> - discards all changes made or moves one level back to the previous menu.

Configuring the **8514-ULTRA**

The **8514-ULTRA** must be programmed with appropriate settings before it will operate correctly. The factory defaults should get your card to power up without a problem. However, to get the best performance from the card, you must configure it with parameters that correctly describe your monitor and system.

Note

Before using your **8514-ULTRA**, it must be configured to your system.

Procedure

Configuring your **8514-ULTRA** is a straightforward process. The selection of parameters is based on multiple choices within a set of menus. Your parameter selections will be checked for system compatibility to ensure conflict-free operation. In the event that you select a parameter already in use by another device, the **INSTALL** program will report an error message. If this occurs, simply correct the situation by choosing a different parameter.

1. Power on your computer and monitor.

If there is an error, re-check your installation or turn to the “Troubleshooting” section in Appendix A.

2. If you are installing the **8514-ULTRA** for the first time, wait for the **C:** prompt to appear on your screen, then insert Disk #1 in the appropriate floppy drive and close the gate.
3. Change the directory from **C:** to the appropriate drive and directory. For example, if you have inserted the Utility Disk #1 in Drive **A:**, type:

```
A: <enter>
```

```
CD\ <enter>
```

If you have previously installed the **8514-ULTRA** Utilities, the installation program should be on your hard disk in the directory

Configuring the 8514-ULTRA

C:\8514UTIL (unless you decided to give the directory another name). Type:

```
C: <enter>
```

```
CD\8514UTIL <enter>
```

4. Type:

```
INSTALL <enter>
```

This will bring up the “Main Selection Menu”, the starting point for all installation and testing functions available to users. Each Main menu selection is dealt with in this guide in the chapters listed at the beginning of this chapter.

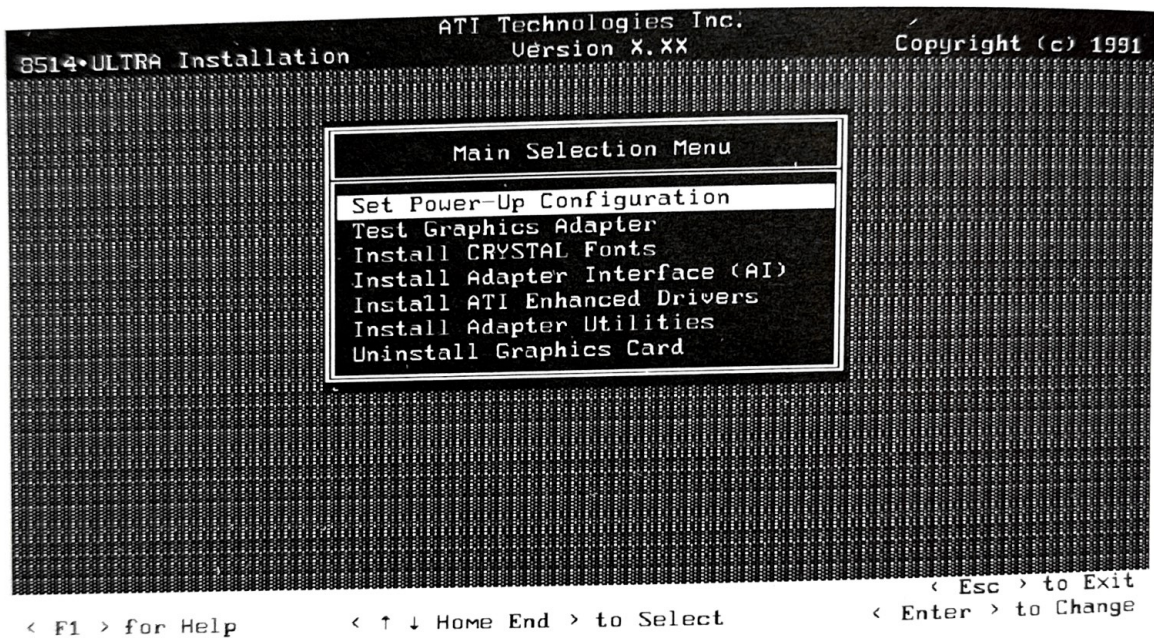

5. To select “Set Power-Up Configuration”, use the <up> or <down> key to highlight the item, then press <enter>. This will open a lower level menu.
6. Select power-up entries as listed in the menu one at a time, and choose the parameters that match your monitor and system. If you need help, press <F1> or refer to Configuration Options in this guide.

The entries in the Set Power-Up Configuration Menu that must be configured are:

- Monitor Type
- Coprocessor Bus I/O
- ROM Address Selection

Warning

Improper monitor type selection could damage your monitor.

7. Once you have chosen all the necessary parameters that match your system and preferences, save the configuration (program the EEPROM) by pressing <F10>. Press <esc> to exit or select another function from “Main Selection Menu”.

Note

You should reboot your system to reset the graphics controller and allow the new parameters to take effect.

Your **8514-ULTRA** should now be properly configured. If you receive any error messages, turn to the Troubleshooting section in Appendix A.

Configuration Options

Monitor Type

This setting determines which video modes will be supported on your monitor. A compatible monitor type must be recorded in the EEPROM in order for the **8514-ULTRA** to give you the best quality image your monitor can offer. Refer to Chapter 4 for information on which monitor to select. If your monitor is not among those listed, choose one that closely matches the resolution, frequency and refresh rate combination supported by your monitor, or choose one of the resolution/refresh rate combinations at the end of the list. If any of the previous parameters are not suitable, select the “Custom...” option and refer to Appendix C for detailed instructions.

If you have a dual monitor configuration, the Monitor Type you select should be the monitor connected to the **8514-ULTRA**.

Coprocessor Bus I/O (ISA systems only)

This option is designed to optimize the performance of the **8514-ULTRA** by selecting the Bus I/O mode most suited to your system.

Auto-Select

This automatic selection mode lets the **8514-ULTRA** check your CPU, setting 80286 systems to 8-bit mode and 80386/486 systems to 16-bit mode.

16-Bit

Configures Coprocessor Bus I/O to 16-bit. Some computer systems may lock up when accessing the coprocessor in this mode. If this is the case with your computer, run **INSTALL** and reconfigure the mode to 8-bit.

8-Bit

Configures Coprocessor Bus I/O mode to 8-bit.

ROM Address (ISA systems only)

Selection of the ROM address will allow the system to detect the **8514-ULTRA** after powering up and prevent conflicts with other cards.

Note

The **INSTALL** program may not correctly detect all devices using memory in ROM address space. Some network and SCSI adapters may not be detected properly by the **INSTALL** program. Consult your network administrator if uncertain.

Move the arrow keys to any location indicated by “.”.

Press <enter> to select the ROM Address location. Your selection will appear on the ROM Address line in the active window.

Note

Select C880 or D000 as a ROM Address. Try another location if these are not marked by “.”.

Storing the Configuration

Once you have finished choosing all the necessary parameters as outlined above, press the <F10> key to permanently store these settings in the **8514-ULTRA**. If you select the <esc> key instead, deciding not to save the current configuration, the card will revert back to the previous information stored in the EEPROM (either the factory defaults or your last stored setting).

Warning

Do not reset or reboot the computer without first configuring the **8514-ULTRA**. The **8514-ULTRA** may have to be removed and reconfigured using the procedure outlined in Appendix A.

Uninstall Graphics Adapter

Select this option if you are moving the **8514-ULTRA** to a different system. This option will erase the contents of the EEPROM, and reset the card to the factory setting.

Warning

The **8514-ULTRA** may not function correctly in another system unless it has been uninstalled before removing the card from the original system.

Software Utilities

8

The software utilities can run from a floppy disk, or if installed, a hard disk. It is recommended that you install the Utilities on your hard disk for quick and easy access.

Procedure

1. Type install or follow instructions in Chapter 7 to bring up the “Main Selection Menu”.
2. Select the “Install Video Adapter Utilities” menu (use the appropriate keys to highlight the item and press <enter>).
3. Accept the destination (drive and directory) as prompted, or type a different destination for the utilities. A new destination directory will be created for you if needed. Press <enter> to continue.
4. Accept the source (drive and directory) as prompted or type in the drive with the disk containing the utilities. Insert disk #1 and press <enter> to start copying.
5. After all utilities have been copied to the hard disk, the prompt will read:

```
Enter Boot Drive
```

Type in the boot drive letter, i.e.:

```
C:\ <enter>
```
6. Installation of utilities is complete. Exit or select another item from “Main Selection Menu”. If you did not select Yes (<Y>) at the prompt, the utilities will not be activated.
7. If you encounter errors or suspect the hard disk is full, refer to the Troubleshooting section in Appendix A.

CRYSTAL Fonts



The Mach 8 coprocessor in your **8514-ULTRA** features an integrated hardware font engine for generating CRYSTAL Fonts. These near-300dpi (dots per inch) fonts offer high resolution text on your screen, closer in clarity and positioning to actual laser printer output than any other screen technology.

Using a technique developed by the Massachusetts Institute of Technology called anti-aliasing, up to 16 shades of grey (or 16 colors) are used to create each font, increasing the perceived resolution and providing a more realistic character shape. Text as small as 6 points is clearly legible on conventional 14" 1024x768 monitors.

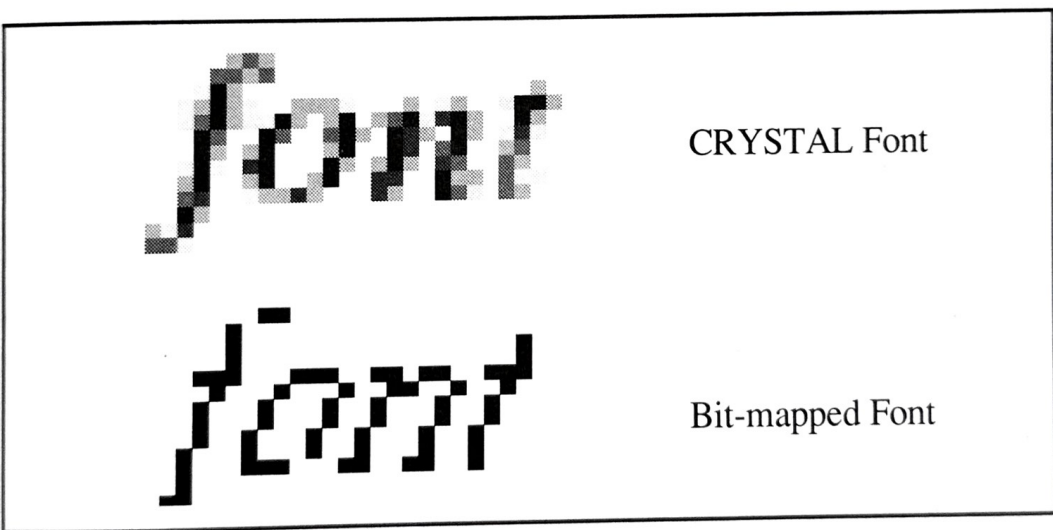

CRYSTAL Fonts work with Microsoft Windows and most software packages that are Windows compatible. CRYSTAL Fonts work in 1024x768 and 1280x1024 resolutions. Windows based programs that use their own proprietary font formats and do not support CRYSTAL Fonts will automatically use their own fonts. Consult your application program vendor to determine CRYSTAL Font compatibility.

The font engine on the **8514-ULTRA** generates 16 versions of each character and determines the best fit. This "automatic kerning" gives true character positioning to within a quarter-pixel accuracy. More than any other screen technology available today, CRYSTAL Fonts

gives you the most accurate picture of how your printed document will look.

The speed and power of the **8514-ULTRA** allows you to scale fonts on the fly. It also allows you to work with an unlimited number of fonts on your screen.

CRYSTAL Fonts will work with other font products that are displayed on your screen at the same time. If your program calls for a font style that you do not have in CRYSTAL Font format, the required font in a different format will be used. The order of preference for font usage by an application program using the ATI CRYSTAL Font driver is :

1. CRYSTAL Fonts.
2. Other scalable fonts (e.g. Adobe Type Manager or FaceLift).
3. Bit-mapped fonts.

When installed, CRYSTAL Fonts also includes CRYSTAL Tune, a utility program that is loaded automatically when you install CRYSTAL Fonts, and shows up as a separate group in Windows Program Manager. This utility will allow you do the following:

- a) Adjust the contrast used in the CRYSTAL Fonts anti-aliasing technique.
- b) Choose the optimal Logical Dots Per Inch (LDPI) for your particular needs (Normal 1024x768/Large Desktop 1280x1024; Desktop Publishing 1024x768; Large Desktop 1024x768; Normal 1280x1024).

The basic CRYSTAL Fonts set included with the **8514-ULTRA** has 13 fonts. The optional CRYSTAL Font Converter provides 22 fonts in Type 1 (Adobe, PostScript, Bitstream) and 8 fonts in Intellifont (HP Laserjet) styles, as well as a conversion utility to translate Adobe, Bitstream or AGFA Intellifont fonts into CRYSTAL Font format. The CRYSTAL Font Converter is available from ATI Customer Support.

Note

Use the coupon attached to the Warranty Card to receive a special discount on the CRYSTAL Font Converter.

Installation Procedure

1. Type:

INSTALL <enter>

or follow instructions in Chapter 7 to bring up the “Main Selection Menu”.

2. Select “Install CRYSTAL Fonts” (i.e. highlight the item and press <enter>).
3. Although the fonts can be copied to any directory, it is recommended you use the destination directory name, GSFONTS, as prompted. Press <enter> to continue.
4. Accept the source (drive and directory) as prompted or enter a different drive (containing the fonts). Insert the appropriate disk and press <enter> to start copying.
5. After all fonts have been copied, the program will offer to add the environmental variable GSFONTS to your AUTOEXEC.BAT file. Press Yes (<Y>) to modify the file.
6. CRYSTAL Font hard disk installation is now complete. To use CRYSTAL Fonts in Windows, you must install the Windows CRYSTAL Fonts driver. Refer to Chapter 10, “ATI Device Drivers”.
7. If you encounter errors or suspect the hard disk is full, refer to the Troubleshooting section in Appendix A.

Device drivers are used by applications to display at different resolutions and color depths. The **8514-ULTRA** will function with standard VGA drivers or 8514/A drivers that come with every major software package. However, to best take advantage of the speed, resolutions, colors and other features of the **8514-ULTRA**, it is highly recommended you install the appropriate drivers from the list below:

- AutoCAD and AutoCAD 386 Release 10 and 11
- OS/2 Presentation Manager
- Windows 3.x

Also included are drivers for:

- AutoShade
- 3D Studio
- MicroStation
- CADKey

Instructions for installing these last four drivers can be found in the README.XXX files in the appropriate subdirectories.

Main Procedure

The procedure to install drivers is composed of two parts: the main procedure that is common to all applications, and a second part which is specific to each application (under the respective heading in this Chapter). Device drivers are located in separate directories by application. Have your application disks and **8514-ULTRA** disks handy before you start.

1. Type:

INSTALL <enter>

or follow instructions in Chapter 7 to bring up the "Main Selection Menu".

2. Select "Install ATI Device Drivers" (i.e. use the appropriate keys to highlight the item and press <enter>).
3. Your screen now shows the "Install Device Drivers Menu". Highlight the application of your choice with the appropriate keys and

press <enter>. The menu will display the source of the appropriate utilities. Insert the proper disk (you will be prompted for the proper disk if the wrong one is inserted). Now turn to the installation procedure for the chosen application that follows in this chapter.

AutoCAD Procedure

ATI provides two (2) AutoCAD drivers: one for AutoCAD (Real Mode) and another for AutoCAD 386 (Protected Mode). This chapter tells you how to load the Real Mode driver. For instructions on loading Soft Engine/386 for ATI, the Protected Mode driver, see Chapter 12.

Installing the AutoCAD (Real Mode) Driver¹

To install the AutoCAD (for Release 10 and 11) Real Mode Drivers from the "INSTALL" menu, select the following options:

Menu 1 - "Install ATI Enhanced Drivers" <enter>

Menu 2 - "AutoCAD" <enter>

Menu 3 - "AutoCAD Release 10" <enter>

To configure the "Real Mode Driver", move the arrow keys to the option and press <enter>. Default settings are described below.

Display Mode

Select the desired resolution with 16 or 256 colors for **8514-ULTRA-1.0MB** or 16 colors for the **8514-ULTRA-512K**. Performance is not affected by the number of colors.

Interrupt Vector

Specifies the interrupt vector location for the **8514-ULTRA** (from 78 to 7F hexadecimal). The default should suffice for most systems. Change if display card error message appears when loading AutoCAD or if using on a Novell network.

Background Field

Specify your choice of either Black (default) or Gray background.

¹ To use the Display List, the driver requires a minimum of 16K of expanded memory. The driver uses 45K of conventional memory, in addition to the memory allocated to the Display List. This driver will also support AutoShade 1.0.

Screen Mode

Select Single Screen (default), Dual Screen (8514/VGA) or Dual Screen (8514/Mono) depending on the system configuration.

Graphic Display/Rendering Display

Used only for AutoShade (version 1.0). Select your choice for saving the file.

Drive to Hold Temporary Files

Specify Drive C or other virtual disk if available.

Display List Expanded Memory

Specify the size of the expanded memory desired. This will automatically be truncated to 16K increments.

Select <F10> to continue and specify the full path of your ACAD directory at the prompt. Press <enter> to complete the installation process.

To start the AutoCAD with the Display List Driver, change into the AutoCAD directory and type:

```
C:\ACAD>AACAD <enter>
```

You can also configure the AutoCAD driver manually with the following options:

```
usage:          ACAD8E10 [options]:
i   :   (gray background) (default: black background)
d   :   dual screen (use dc if) (default: single screen)
fn[path] : alternate font (default VGA ROM font)
n=1 :   12x29 (default path: c:\hpicdos\stan1220.fnt)
n=2 :   8x14 (default path: c:\hpicdos\stan0814.fnt)
l   :   16 colors (default: 256 colors)
v?? :   hexadecimal interrupt vector (default: vector 7Ah)
g   :   request to save graphics display (default: disabled)
r   :   request to save rendering display (default: disabled)
u   :   Unload ADI driver from memory. If the driver was installed
       :   with a different interrupt vector than 7Ah, precede the "u"
       :   option with the "v??" Interrupt Vector that was installed.
s?  :   select drive for temp file (default: drive c:\)
e?? :   decimal Expanded Memory Pages (default: 16 pages 256K)
h   :   this message
?   :   this message
```

Using the Display List

The 8514-ULTRA's Display List Driver adds two new functions to AutoCAD:

1. Bird's Eye View
2. Display List Meter

Bird's Eye View

To operate the Bird's Eye View, move the cursor into the Display List Meter selection on the bottom right hand corner of the screen. The menu will change to read "Birdseye"; Click on the left mouse button to select. Bird's Eye can also be activated by typing at the command line:

BEV <enter>

A zoom box or Bird's Eye box will appear on screen, as shown below:

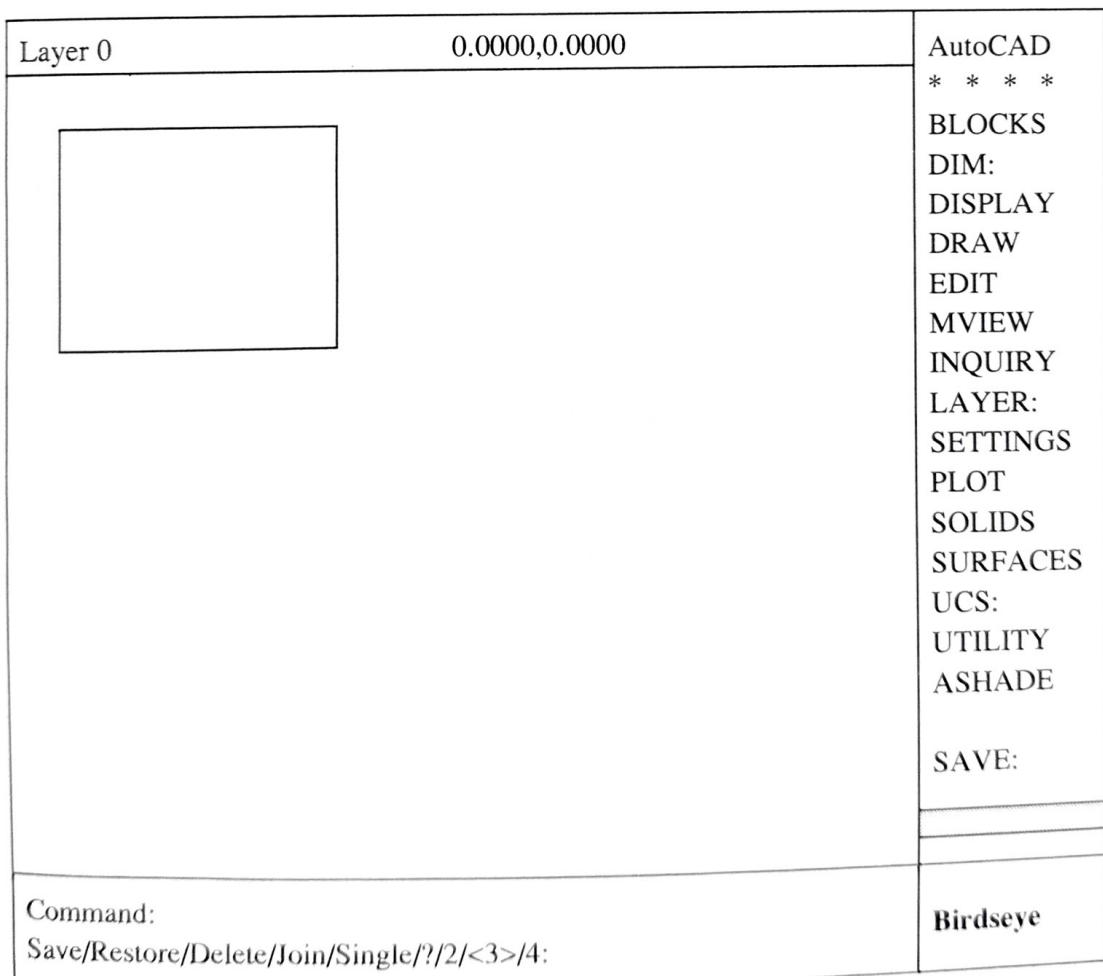

The left mouse button will allow you to dynamically adjust the size of the Bird's Eye. After selecting the Bird's Eye, click on the left button

to resize the box. Move the mouse until the box is the size required; click again on the left button to select that size.

Move the zoom box to the area of the drawing you wish to view in more detail. Press the right mouse button to zoom in on the view. The view will be magnified and the Bird's Eye box will disappear.

To exit the Bird's Eye without zooming in on an area, move the cursor to the AutoCAD icon in the upper right at the screen and click the left button.

The outer boundaries of the active view contained in the Display List will be surrounded in a flashing white box. If you elect to zoom in on an area outside the Display List, or attempt to zoom in for too much detail, a REGEN warning will appear on the top of the AutoCAD menu bar.

Note

Bird's Eye View will not operate on a Viewport that is displaying a "Perspective" view. This is an AutoCAD restriction.

Display List Meter

When adding lines and solids, zooming, panning or changing the active view, you will notice that the numbers on the Display List Meter at the bottom right corner of the screen will change with each operation. With each operation, the contents of the Display List are updated to include the new vector information.

Layer 0	0.0000,0.0000	AutoCAD * * * *
		BLOCKS DIM: DISPLAY DRAW EDIT MVIEW INQUIRY LAYER: SETTINGS PLOT SOLIDS SURFACES UCS: UTILITY ASHADE SAVE:
Command: Save/Restore/Delete/Join/Single/?/2/<3>/4: Command:		X of XXXX K

Because you set the capacity of the Display List, it is useful to monitor its contents with the Meter. When you exceed capacity of the available Display List, AutoCAD will redraw at its normal speed with the Display List function. This will be displayed as X+1 of XK. AutoCAD will now act as if the Display List is disabled and will regen at the next redraw, emptying and enabling the Display List once again.

Note

If you are consistently filling the Display List, increase the size of the Display List memory.

Presentation Manager for OS/2 Procedure

To install this driver, you must have OS/2 version 1.2 or 1.3 already installed with a DOS box having at least 512K of memory available. When OS/2 is first installed, choose the VGA driver. The **8514-ULTRA** hardware must be set up before installing this driver. Run the **8514-ULTRA** INSTALL program (from disk #1) in the DOS

box, and follow the instructions for configuration in Chapter 7. The ATI Presentation Manager driver may now be installed. The INSTALL program must be run from the DOS box. Follow the instructions provided in the Main Procedure above.

1. Select the desired resolution: 640x480, 800x600 or 1024x768.

Note

If the resolution you have just chosen has not been installed on the **8514-ULTRA** using the “Set Power-Up Configuration”, the Presentation Manager driver will switch to whatever resolution has been set up, regardless of your choice in the Presentation Manager driver setup. If no resolution has been set up, the driver will default to 640x480.

2. Press <F10> to install driver. Then press <esc> to exit or select another function from the “Main Selection Menu”.
3. Reboot your system to activate the Presentation Manager driver.

Windows 3.x Procedure

The **8514-ULTRA** comes with seven (7) different Windows 3.x drivers. Each driver has its own special characteristics. Once installed, you can change drivers by simply going into the Windows Setup program during a Windows session, highlight and enter the driver you want, and restart Windows.

If you want to use CRYSTAL Fonts in Windows, you must install CRYSTAL Fonts before choosing the appropriate CRYSTAL Fonts driver. If you have not installed CRYSTAL Fonts, see Chapter 9, “Installing CRYSTAL Fonts” for further details.

The **8514-ULTRA** comes with the following Windows drivers:

Driver	Graphics Accelerator Coprocessor Memory	
	512K Installed	1.0MB Installed
ULTRA:640x480 (use with standard VGA monitors).	640x480/16 colors Normal character size	640x480/256 colors Normal character size
ULTRA:800x600 (use with SuperVGA monitors).	800x600/16 colors Normal character size	800x600/256 colors Normal character size
ULTRA:1024x768 (use with 1024 monitors).	1024x768/16 colors Normal character size	1024x768/256 colors Normal character size
ULTRA:1024x768 for Big Desktop/Small Fonts (use with large monitors)	1024x768/16 colors Small character size	1024x768/256 colors Small character size
ULTRA:1024x768 with CRYSTAL Fonts	1024x768 monochrome CRYSTAL Fonts characters	1024x768/20 colors CRYSTAL Fonts characters
ULTRA:1280x1024 (use with monitors capable of 1280 interlaced mode).	N/A	1280x1024/16 colors Normal character size
ULTRA:1280x1024 with CRYSTAL Fonts	N/A	1280x1024 monochrome CRYSTAL Fonts characters

Part I

This section provides the procedure for copying Windows drivers to your hard disk. You must then run the Windows setup program to update the Windows configuration files and use the new driver. You can do this by setting up drivers from the DOS command line or from within Windows (Part II).

1. Select a screen driver type. If you select the CRYSTAL Fonts driver, you must have at least 1.0MB of coprocessor memory if you want a color display at 1024x768 or a monochrome display at 1280x1024 (see chart on previous page).
2. Specify the directory where your Windows program is installed. When you press <enter>, the necessary files will be copied to that directory and Windows SETUP.INF will be modified.
3. When copying is completed, record the screen message about how to reconfigure Windows using Windows SETUP.EXE in order to use the driver you just copied.
4. Press <esc> to exit or select another function from the "Main Selection Menu".

You must now run **SETUP** for Windows. You can reconfigure Windows from the DOS command line (C:\) or from within Windows itself.

Part II

Screen Driver **SETUP** from **DOS**

1. Have your Windows disks ready.
2. Go to the Windows subdirectory by typing:
CD\
CD WINDOWS
3. To get into the Windows configuration program, type:
SETUP
4. Use your direction keys to highlight "Display" and press <enter> to display a list of the available drivers.
5. Use your direction keys to highlight the driver of your choice. The program will ask for certain disks to copy relevant files to the hard disk where applicable. **SETUP** will modify the configuration files and return to the DOS command line when completed.

Screen Driver **SETUP** within **Windows**

1. After you have successfully copied the screen driver to the Windows subdirectory (Windows 3.x Procedure, Part I), start Windows.
2. Select the Windows Setup Icon to start the **SETUP** program.
3. Select "Options", then "Change System Settings..." to display the settings menu.
4. Highlight "Display" and select the driver of your choice. The name of the driver should now be displayed in the **SETUP** screen. Press <enter> to continue.
5. Close the screen. Windows configuration files will be updated. You will be prompted to either "Restart Windows" or "Return to DOS".

The ATI Turbo Adapter Interface



There are two categories of software drivers which support the IBM 8514/A graphics adapter:

1. Direct-to-register: those which write directly to the 8514/A registers.
2. Adapter Interface: those which access the 8514/A through the Adapter Interface (AI).

Direct-to-register software writes directly to the registers of the 8514/A. Examples of such programs are: Microsoft Windows, OS/2 Presentation Manager, and the ATI AutoCAD Display List Driver. If you have followed the installation instructions in the preceding chapters, these programs will run right out of the package without any further preparation.

Many programs access the 8514/A using a software interface designed by IBM called the 8514-AI (Adapter Interface). Examples of programs that use this interface are: Lotus 1-2-3, WordPerfect, and Turbo-Pascal. Most DOS-based programs use the AI approach. Contact your application program vendor for information on AI support modes.

The ATI Turbo Adapter Interface (AI) is a programming interface written exclusively for the ATI **8514-ULTRA**. The AI provides access to the Mach 8 coprocessor by providing a "call interface" to programs performing display functions in the 8514/A compatible part of the **8514-ULTRA**. It is 100% compatible with AI programs written for the IBM 8514/A.

Any application that needs the Adapter Interface will ask for a TSR (Terminate-and-Stay-Resident) program called HDILOAD.EXE. The **8514-ULTRA** comes with two versions of the HDILOAD.EXE program: one for DOS and one for OS/2.

Installing HDILOAD.EXE for DOS

1. Type INSTALL or follow instructions in Chapter 7 to bring up the “Main Selection Menu”.
2. Select “Install Adapter Interface for DOS” (i.e. highlight the item and press <enter>).
3. Although you may copy AI files to any directory on your hard disk, certain applications require that the AI resides in a directory called \HDIPCDOS. Accept the destination as prompted on the screen. If the named directory does not exist on the destination drive, one will be created for you. Press <enter> to continue.
4. Accept the source (drive and directory) as prompted, or enter the path (drive and directory) which has the AI files. Insert the appropriate disk and press <enter> to start copying.
5. The program will attempt to add a path reference to the AI directory and modify your AUTOEXEC.BAT file to load the AI automatically on every power-up. If you wish this, press Yes (<Y>) when prompted.
6. AI installation is complete. Exit or select another function from the “Main Selection Menu”. If you encounter errors or suspect the hard disk is full, refer to the Troubleshooting section in Appendix A.

How to Load/Unload the ATI Turbo AI

Loading the AI

If you let the installation program modify your AUTOEXEC.BAT file, the ATI Turbo AI will be loaded automatically at every power-up. If you refused the installation program’s request to automatically load the AI, you must manually execute the AI immediately after reboot and before starting any programs requiring AI support. If your AUTOEXEC.BAT file does not contain a “load” line, you can load the AI yourself by typing:

```
C:\HDILOAD <enter>
```

Unloading the AI

The HDILOAD.EXE is a TSR which loads itself into memory and stays there until the computer is rebooted or powered-off. Although the HDILOAD.EXE program only needs 18K of memory, it may be unloaded from memory, allowing applications which do not require AI

support to use this additional memory. To remove the AI from memory, type:

```
C:\HDILOAD UNLOAD <enter>
```

Note

Programs that use the AI will display an error message if the AI is not present before starting the application.

Note

The order of removing TSR programs (if you have more than one) from DOS memory is important. Refer to your DOS manual for details. The Turbo AI should not conflict with other TSRs. If problems occur, remove all other TSRs.

Installing the ATI Turbo AI for OS/2

Refer to the HDIOS2 directory on the **8514-ULTRA** disks which include a README file with full instructions for installing the ATI Turbo AI for OS/2.

Soft Engine/386 for AutoCAD 386

12

Introduction

This special edition of Soft Engine/386, written for the ATI **8514-ULTRA**, is a display list software driver designed to improve the performance of AutoCAD 386 Release 10 and 11 by increasing the speed at which AutoCAD display commands are executed by as much as 1000%.

Soft Engine/386 is also designed to improve the user's satisfaction with AutoCAD by providing an enhanced user interface for controlling the display.

Soft Engine/386 is also a protected-mode ADI driver designed to improve the user interface of other Autodesk products by implementing the full resolution of your graphics board and monitor and by providing the means to customize many of the presentation parameters.

Soft Engine is for use with Autodesk protected-mode applications only, such as:

- AutoCAD 386 Releases 10 & 11
- AutoShade 2.0 386
- Autodesk RenderMan
- Autodesk 3D Studio 1.0

Key Features

The most important features include:

- Accelerated pan, zoom, and view commands.
- Bird's Eye Windowing for quickly moving across the drawing without zooming out.
- Auto GC Trigger that prevents display lists from growing inappropriately and causing excessive swapping.
- Fast Figure Drag for precise object placement during move and copy commands.
- Use of extended and expanded memory via AutoCAD's virtual memory manager, thereby avoiding memory space conflicts.
- Full 32-bit performance for all drawing operations.

- Protected-mode design allows it to become an integral part of the application and requires none of the 640K DOS RAM.
- Full color configuration, palette customization and font selection where appropriate.

System Requirements

To run Soft Engine/386 your computer system must be capable of running the intended Autodesk protected mode application and you must own an ATI **8514-ULTRA**.

When Soft Engine is being set up to run AutoCAD 386, we strongly recommend the use of additional memory. Autodesk recommends running AutoCAD 386 with at least 4.0MB of memory (though the program is able to crawl with only 2.0MB).

We strongly recommend more than 4.0MB of memory to run at optimal performance with drawings over 400K in AutoCAD.

Rule of Thumb

A good rule of thumb is to have as much additional memory for Soft Engine, over that in which AutoCAD 386 normally runs, by one third the size of your average drawing for each master view.

For example, if you work on 1.0MB drawings and AutoCAD runs satisfactorily on a 6.0MB system, you would need about 6.33MB of memory to comfortably run the system with one master view.

However, since extended memory does not generally come in fractional increments, in reality you would need a total of 8.0MB.

Before Installing Soft Engine/386

A Note to Experienced Users

Soft Engine is compatible with all of Autodesk's other protected-mode driver installation methods. Feel free to use another method if you prefer.

If you are running more than one copy of AutoCAD on a system or want to run Soft Engine from a network server, see the documentation on using the DSPADICFG Environment Variable in the README file contained on your program disk.

A Note to AutoShade & 3D Studio Users

For those of you wanting to run Soft Engine/386 with either AutoShade 2.0 or 3D Studio 1.0, follow the installation and configuration instructions contained in the README file on your installation disk.

Installation

Specific AutoCAD Installation

1. Place disk #2 in your floppy drive and log on to that drive.
2. At the DOS prompt, type INSTALL followed by the drive and directory containing AutoCAD; for example:

```
INSTALL C:\ACAD <enter>
```

and press <enter>.
3. Read the screen, then press any key.
4. Soft Engine's install will copy the files into the AutoCAD directory and rename the Soft Engine program to ADIDISP.EXP so that AutoCAD will automatically find it.
5. Turn several pages to Configuration and Usage for AutoCAD to continue.

General AutoCAD, AutoShade and 3D Studio Installation

If you plan to use Soft Engine with AutoShade and/or Autodesk 3D Studio, it is very important that you follow these directions. Soft Engine must know which AutoCAD application it is supporting and the applications themselves are unable to communicate that. This means that installation is a little more challenging.

1. Make a directory for Soft Engine. For example:

```
MKDIR C:\SE <enter>
```
2. Copy all of the files from your Soft Engine/386 disk into it. For example, type:

```
COPY A:*. * C:\SE <enter>
```
3. Edit your AUTOEXEC.BAT file to contain the following parameters:

```
SET DSPADI=C:\SE\SOFTENGN.EXP  
SET RDPADI=C:\SE\SOFTENGN.EXP  
SET RCPADI=C:\SE\SOFTENGN.EXP  
SET DSPADICFG=C:\SE\SOFTENGN.CFG
```
4. Reboot so that the changes to the AUTOEXEC.BAT take effect.

5. Continue with the Configuration and Usage section for each of the applications in which you intend to use Soft Engine. Configuration and usage for AutoShade and 3D Studio are in the README file contained on your program disk.

Configuration for AutoCAD

Soft Engine replaces any other display drivers that you may have installed for use with AutoCAD. All of Soft Engine's features are customizable to meet your individual tastes.

Configuration

In order to have AutoCAD use Soft Engine as its display driver we'll have to go through several steps.

Selecting Soft Engine as Display

1. Enter AutoCAD as usual, either through a batch file, menu, or by typing ACAD at the DOS prompt.
2. If you've configured AutoCAD in the past, enter the Configure AutoCAD function and opt to change the video display configuration. If AutoCAD has not previously been configured, the system will automatically ask you to select your video driver. In either case, select 1. ADI P386 display.

Video Mode Selection

3. After selecting the ADI P386 display driver, the Soft Engine logo screen will automatically appear followed by a window showing your current video mode. The system asks:

Do you wish to change the video mode?

4. The Soft Engine default is the ATI 8514 1280x1024, 16 color mode. To leave the software set for that mode, select No by typing <N> or pressing <enter>. Then continue with Accepting/Modifying Soft Engine Defaults further on in this section.

To change the video mode select Yes by typing <Y>.

5. If you chose to change the mode, a list of possible selections appears.
6. Highlight the appropriate mode using the arrow keys, then press <enter>.

Testing the Video Mode Selection

1. Next, Soft Engine will display the name of the selected mode and ask:

Do you wish to test the video mode?

2. If you answer <N> for No, the system proceeds with the next phase, Accepting/Modifying Soft Engine Defaults, outlined in the next section.

If you answer Yes (<Y>), and the video mode is correct, a test screen should appear.

If your screen is blank or garbled characters appear, there is a problem with the video card or your monitor doesn't support the particular resolution selected.

3. After about 10 seconds the following message appears:

Did the Graphics Test Screen appear correct?

4. If everything is correct, answer Yes (<Y>), and continue with the next section, Accepting/Modifying Soft Engine/386 Defaults.

If the screen was not satisfactory, answer No (<N>), and you will be returned to the video mode selection screen. Follow the same instructions starting with step 7 under Video Mode Selection.

If none of the selections you want to use work, call us at (416) 756-0711 so we can help you fix the problem.

Accepting/Modifying Soft Engine/386 Defaults

1. Next, a screen appears showing the default settings for the following:

- Single or Dual Screens
- Number of Command Lines
- Zoom Button Number
- Overall View Button Number

The screen asks:

Do you wish to change any of the above settings?

2. Answer No (<N>), if the parameters are appropriate and proceed with Exiting Configuration/AutoCAD Defaults.

Answer Yes (<Y>), if you wish to change anything. Then continue below.

Single or Dual Monitors

Dual screens let you use one display for graphics while using another display for AutoCAD's command prompts. The default is single monitor.

3. Type S or D as appropriate.

If you select dual monitors, be aware that we have several dual screen operating modes available. The default mode of FAST operation is appropriate 95% of the time. See the Custom Configuration section located in the README file on your program disk for details and instructions.

Number of Command Lines

Select from 0 to 25 lines to appear at the bottom of the graphics screen. The fewer the lines the faster the scroll rate. Using 0 is only appropriate with dual monitors.

4. Type the number and press <enter>.

Zoom Button Number

Zoom Window and Preview Zoom are preset for the second button plus the Shift button on your pointing device. Soft Engine numbers the buttons from left to right beginning with 1.

Since most users prefer to keep the AutoCAD commands already programmed for the buttons on their input device, the default configuration is set so that the pointing device buttons require you to use <shift>, <ctrl> or <alt> on the keyboard for Soft Engine commands. This is indicated by adding 100 to the desired button number, i.e. 102 for the second button. Entering a number above 100 will allow you to use any of the three toggle keys to get the alternative Soft Engine functions.

Entering <0> disables the feature.

Please refer to the section on Suggested Button Configuration on the following pages for ideas on how to set up your digitizer, mouse or stylus.

5. Type the new number and press <enter>.

Overall View Button Number

This button is for the two overall view functions of Zoom All and Bird's Eye. These functions are preset for the <shift>, <ctrl> or <alt> keys in conjunction with the third button on your pointing device.

Just as with the Zoom button, you add 100 to the desired button number to use the button with the <shift>, <ctrl> or <alt> keys.

Entering <0>, disables the feature.

Please refer to the section on Suggested Button Configuration on the following pages, for ideas on how to set up your digitizer, mouse or stylus.

6. Type the new number and press <enter>.

7. The screen will again ask:

Do you wish to change any of the above settings?

Answer No (<N>), to continue. Answer Yes (<Y>), to make further changes.

Entering Custom Configuration

1. After dealing with the defaults, Soft Engine will ask:

Do you wish to enter Custom Configuration?

2. You may type <Y> for Yes and enter Custom Configuration. If you type <N>, you may enter Custom Configuration, described in detail in the README file located on your program disk, at anytime from the AutoCAD command line by typing SECONFIG.

Please see the section on Custom Configuration for complete instructions on customizing the following parameters for use with AutoCAD:

- Auto GC Trigger Value
- Bird's Eye Save to Default
- Button Timing
- Menu Color Scheme
- Font Selection
- Number of Status Lines
- Palette Selection
- Operational Parameters

Exiting Configuration/AutoCAD Defaults

1. After responding to the screen options on the previous pages, Soft Engine will take you back to AutoCAD Configuration. AutoCAD will ask you about the following:

- Aspect Ratio
- Status Line
- Command Prompt
- Screen Menu Area

Aspect Ratio

2. Press <enter> or change as appropriate.

In general, it is better to adjust the monitor than to try changing this.

Status Line

3. Press <enter> or change as appropriate.

Command Prompt

By answering <N>, No, to this prompt, it will override the number of command lines set previously in Soft Engine Defaults.

4. Press <enter> or <Y> to answer Yes to this prompt.

Screen Menu Area

5. Press <enter> or change as appropriate.
6. Exit the Configure AutoCAD function. Be sure to answer <Y>, Yes, to save your changes.
7. Your basic configuration is now complete. Enter the drawing editor.

Usage with AutoCAD

By using Soft Engine/386 you can access all of the regular AutoCAD commands for zooming and panning (as explained in the AutoCAD manual). But Soft Engine also provides faster, easier methods to perform these functions using the buttons on your input device or our keyboard commands. Soft Engine's direct interface can be used in the middle of any drawing command without disrupting the work in progress.

Button Defaults

The default button selections for the direct interface are set up for a standard three button mouse as follows:

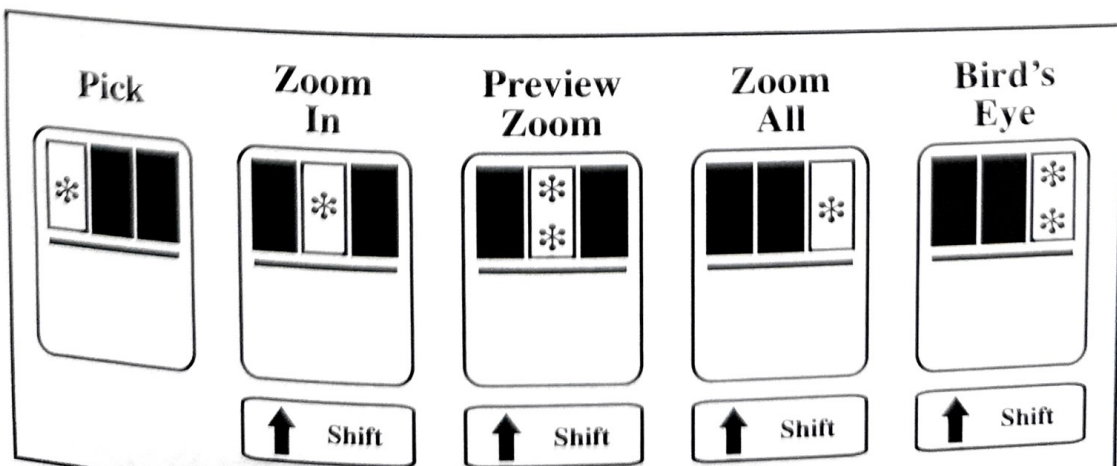

A single or double click is required as indicated by the asterisks as well as holding down either the <shift>, <ctrl> or <alt> keys, except for the pick button.

If you need to set up the buttons in a different way, refer to the Basic Configuration section of this manual.

Keyboard Commands

All Soft Engine's functions can be accessed by typing one or more keyboard commands. These commands can also be entered at almost any AutoCAD command prompt by prefixing them with an apostrophe, such as 'ZW.

Direct Interface

Zoom Functions

Four types of zooms are available in Soft Engine: Zoom Window, Preview Zoom, Zoom All and Zoom Previous.

The first three have been assigned to default buttons on your input device. To change the defaults, refer to the Basic Configuration section.

The functions of each zoom type are described below.

Zoom Window

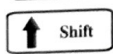

The Zoom Window function allows you to select a portion of the drawing to immediately magnify to fill the entire screen. It will not allow you to preview the aspect ratio of the viewport and reposition the window as Preview Zoom will.

To use Zoom Window on your drawing:

1. Press the Zoom button once. You may also type ZW or ZI. Don't forget to use the <shift>, <ctrl> or <alt> key.
2. If you're using the Zoom button, go to step 3. If you're using the keyboard commands, use the Pick button to select the starting position of the window.
3. Next, Pick the other corner of the window frame.
4. The area designated will fill the entire screen or viewport.

To cancel the zoom in the middle of the command, press any other button or key.

Preview Zoom



Preview Zoom is most applicable for use with multiple viewports. When you select an area to zoom, Preview Zoom immediately shapes the select box into the aspect ratio of your current viewport and allows you to frame your selection appropriately before it is drawn on the screen.

To Preview Zoom:

1. Double click the Zoom button or type PZ. Don't forget to use the <shift>, <ctrl> or <alt> key.
2. If you're using the Zoom button, go to step 3. If you're using the keyboard command, Pick the starting position of the zoom window.
3. Next, Pick the other corner of the window frame.
4. The window will immediately snap to the viewport's aspect ratio. Reposition the window, if necessary, by moving the input device.
5. When the window is in position, press Pick again.
6. The section you have chosen will fill the viewport.

To cancel the Preview Zoom in the middle of the command, press any other button or key.

Zoom All



Zoom All allows you to zoom out to view the entire drawing or full display list without AutoCAD automatically doing a regen. You can quickly use Zoom All in the middle of any command without interrupting your work.

To use Zoom All:

1. Press the Zoom All button once or type <ZA>. Don't forget to use the <shift>, <ctrl> or <alt> key.
2. Your drawing will show the entire view.

Zoom Previous

Selecting Zoom Previous returns you to the most recent zoom level. Using this function you can back up sequentially through eight (8) previous zoom levels.

To use Zoom Previous:

1. Type ZP or ZX.

2. Your drawing will show the previous view.
3. To select the next previous level, type the letters again.

Bird's Eye Functions

The Bird's Eye Window is a viewport containing the entire drawing or full display list. It shows the zoomed section in proportion to the larger picture. The Bird's Eye is a handy tool to keep you from getting lost in the proverbial forest while dealing with the trees.

The Bird's Eye can be used to quickly zoom in to another portion of the drawing, or to pan across at the current zoom level to another area.

Just like the Zoom function, the Bird's Eye has been assigned a default button. The Bird's Eye default is a double click on the third button along with the <shift>, <ctrl> or <alt> key. To change that default, see the Basic Configuration section of this manual.

The size and position of the Bird's Eye Window has also been assigned defaults which can be easily changed. You can also designate the Bird's Eye to be on at all times or to display on demand.

Specific Bird's Eye functions are described in more detail on the following pages.

Bird's Eye Configuration

Although the Bird's Eye has been configured, you may want to change the settings. To set the parameters:

1. If you're using multiple viewports, pick the one to attach the Bird's Eye.
2. Type:
BIRDSEYE <enter>
3. The following message appears in the AutoCAD command prompt area:

Leave Bird's Eye View On Always? (Yes/No/Off)

Select (<Y>) for the Bird's Eye to always appear when you are drawing or editing in AutoCAD. This is Permanent Mode.

Select (<N>) to have it appear on demand at it's designated size and position. This is Temporary Mode.

Select (<O>) and changes to the drawing will not be reflected in the Bird's Eye, so the entire system runs faster.

4. Next, a movable black and white rectangle appears on the screen. This is the Bird's Eye.
5. To enlarge the Bird's Eye, press the Second button on your input device or the Plus (<+>) key.
6. To reduce the Bird's Eye, press the Third button or Minus (<->).
7. Next, position the Bird's Eye on the screen and press the Pick button.

The new configuration parameters are now saved as the default.

Entering & Exiting the Bird's Eye



To enter the Bird's Eye:

1. Double click the Bird's Eye button or type BE. Don't forget to use the <shift>, <ctrl> or <alt> key.

You may then perform zoom and pan operations relative to the Bird's Eye as described on the following pages.

To exit the Bird's Eye:

1. Single click the Bird's Eye button from within the Bird's Eye Window, press <esc>, or press any two of the following keys: <shift>, <ctrl> or <alt>.

(Remember, a single click of the Bird's Eye button in the main viewport will perform a Zoom All.)

Zooming within the Bird's Eye

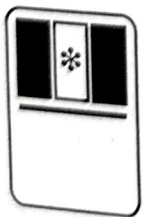

The advantage of using the Bird's Eye function for zooming is that it prevents you from having to zoom completely out and then back in again.

To Zoom using the Bird's Eye:

1. Enter the Bird's Eye.

2. Move the arrow to the lower left corner of what will become the Zoom Window.
3. If you're using a mouse or digitizer, single click the Zoom button. If you're using a stylus, double click the Pick button.
4. Now move the arrow to select the upper right corner of the Zoom Window and press the same button again.
5. The newly selected area will immediately appear in the appropriate viewport.
6. Repeat a zoom, do a pan or exit the Bird's Eye.

Panning within the Bird's Eye



The Pan function works within the Bird's Eye to move the Zoom Window to another area within the Bird's Eye. The zoom level remains the same.

To use the pan capabilities within the Bird's Eye:

1. Zoom to the desired level on a portion of your drawing.
2. Enter the Bird's Eye.
3. Move the arrow into the highlighted zoom box in the Bird's Eye.
4. Press the Pick button. The current zoom box will move as you move your input device.
5. Move the box across the Bird's Eye to the desired location.
6. Pick again and the new area will appear in the appropriate viewport.
7. Exit the Bird's Eye.

Redraw

You can initiate AutoCAD redraws in an active viewport using this familiar shorthand.

To quickly start a Redraw:

1. Type:

RD <enter>

Redraw All

An extension to the Redraw command is Redraw All which initiates a Redraw in every viewport.

To Redraw All:

1. Type: `RDALL <enter>`

Garbage Collection

Sometimes while performing a zoom, recently erased objects will flash on the screen. Another problem occurs when a solid object is placed over a part of the drawing, then erased: when you perform a zoom, that part of the drawing will appear to be missing. Use the Garbage Collection command to solve both of these problems.

The Garbage Collection command gets a new display list from AutoCAD that has been purged of erased objects. It is used when the AutoCAD REGEN command will take too long and the Auto GC Trigger Value has not been exceeded.

To initiate Garbage Collection:

1. Type: `GC <enter>`

This command will take a moment.

Garbage Collection All

This command requests a new display list for each viewport on the screen, not just the active one.

To initiate Garbage Collection All:

1. Type: `GCALL <enter>`

Note

Be sure to see the discussion of the Auto GC Trigger Value in the Custom Configuration section of this manual.

Help

Help screens are available for Soft Engine. To access these screens:

1. Type:
`SEHELP <enter>`
2. To exit the Help section, press <esc>.

Status

The Status function shows the amount of memory in use by the Soft Engine display list.

To access the Status function:

1. Type:
`SESTATUS <enter>`

Custom Configuration

Please see the section on Custom Configuration for complete instructions on customizing the following parameters for use with AutoCAD:

- Auto GC Trigger Value
- Bird's Eye Save to Default
- Button Timing
- Menu Color Scheme
- Font Selection
- Number of Status Lines
- Palette Selection
- Operational Parameters

To reach Custom Configuration from within AutoCAD:

1. Type:
`SECONFIG <enter>`

Suggested Button Configurations

The following are suggested configurations for some of the types of pointing devices available.

Sixteen Button Digitizer

Assign buttons 5 and 9, along with the <shift>, <ctrl> or <alt> key, as the Zoom and Overall View buttons. They're easy to get to because they're directly under the Pick button.

Four Button Digitizer

Assign the third and fourth buttons, along with the <shift>, <ctrl> or <alt> key, to be the Zoom and Overall View buttons, respectively.

Three Button Mouse

If you don't often use the AutoCAD commands already on those buttons, simply use our defaults. Remember, you will only get the Soft Engine commands if the crosshairs are on the screen. If the cursor is on one of the menus, you'll get the AutoCAD commands.

By using your buttons in conjunction with the <shift>, <ctrl> or <alt> keys, you will be able to use those AutoCAD commands already assigned to your mouse buttons

Two Button Mouse

The best bet is to program the Zoom button to be Shift + the Pick button and the Overall View button to be Shift + the second button. This allows Pick and Enter to be used as normal under the AutoCAD configuration without the Shift key.

Stylus or Other Single Button Device

Program the Overall View button as Shift + the Pick button. This way you can pick things on the screen, or use Shift + a single click for Zoom All and Shift + a double click for the Bird's Eye. Once you're inside the Bird's Eye you can continue as documented to pick inside the area for pan, pick outside the area for zoom or double click to zoom at any time.

International Usage

Non English Version of AutoCAD

Several of Soft Engine's commands work by sending AutoCAD the strings REDRAW or REDRAWALL.

If you are using a non-english version of AutoCAD, several of Soft Engine's commands will not work.

To solve this problem, you may define the REDRAW and REDRAWALL strings that are sent to AutoCAD by using the REDRAW and REDRAWALL environment variables.

For example, the French version of AutoCAD will require the following environment variables:

```
SET REDRAW=REDESS
```

```
SET REDRAWALL=REDESTOUT
```

Do not place any spaces after the definitions.

Appendix A

Troubleshooting and Diagnostics

The **8514-ULTRA** comes with two diagnostic programs: a self-test that is performed on power-up and one that can be performed by the user.

Automatic Power-Up Test

When the computer is first turned on, the **8514-ULTRA** initializes itself and then runs through a self-test procedure, checking each component of the adapter.

If an error is detected, a diagram of the board will appear on-screen.

The fault is indicated by a flashing component indicating an error code.

Error Messages

Errors are followed by a pictograph indicating the possible defective component.

Error messages are in the format:

```
142nn xxxx xxxx Error message
```

where 142 is the error code identifying the **8514-ULTRA**.

nn is the error number.

xxxx addition error information.

While attempts are made to be as accurate as possible, conflicts with other system components may result in error messages not related to the graphics adapter.

14201 Video Adapter Not Detected

Indicates that no **8514-ULTRA** is present in the system. If the card is actually present, this message would indicate a severe failure (i.e. I/O conflict with another board, bad bus timing, bad gate array, or a bad board).

14202 Pass Through Connector Configuration Error

Occurs when a VGA Card is attached to a digital monitor and the pass through cable connected. This is an invalid configuration and may

cause irreparable damage to the monitor connected to the card. Disconnect either the digital monitor or the pass through cable.

14203 Subsystem Failure

Indicates a severe failure.

14204 Graphics Subsystem Failure

Generic error which indicates an error with the coprocessor. Should be treated as a severe failure. Ensure that no device uses COMM port 4 (I/O port address 2E8).

14205 RAMDAC Failure

Indicates a failure in the RAMDAC test. Contact ATI's Customer Support.

14206 RAM Failure

Indicates a RAM data error. If 1, 2 or 3 RAM chips are flashing, then the RAM chips are suspect. If every second RAM chip is failing, check the JU3 (MEM_SIZE) jumper. Multiple RAM failures would suggest a board level fault.

14207 RAM Addressing Failure

Should be treated as a RAM data failure.

14208 POST ROM Checksum Failure

An error has occurred during the POST ROM self check. Check that the ROM address does not conflict with anything else. In Micro Channel systems, the ROM address is not configurable and must reside at C680.

14209 Configuration Failure

Indicates a bad EEPROM. Run the INSTALL utility again and re-boot. If the problem persists, it is a board failure.

14213 FIFO Overflow Failure.

Indicates a severe failure.

14214 Data Not Ready Failure.

Indicates a severe failure.

14215 ROM Paging Failure.

Occurs if ROM shadowing is enabled for the ROM or if there is an I/O conflict with register 46E8 of the VGA.

14216 Post RAM Examination Failure.

Occurs after the contents of screen memory have failed to compare against a known set of results following a test sequence.

INSTALL - Test Graphics Adapter

The INSTALL program has two options for testing the **8514•ULTRA**:

Diagnostic Test

The Diagnostic Utility contains detailed tests of the video display modes and the **8514•ULTRA**.

ROM Integrity Test

Performs a CRC checksum on the boot ROM. Fails if the ROM is bad or if there is a ROM address conflict. This test is skipped if the **8514•ULTRA** has not yet been installed.

Register Integrity Test

Performs writes and reads to some of the **8514•ULTRA** registers. An error with this test indicates a severe failure.

FIFO Integrity Test

Tests the FIFO. An error with this test indicates a severe failure.

RAMDAC Integrity Test

Tests the RAMDAC.

Video Memory Test

Tests the integrity of the video memory chips. If one, two or three RAM chips are flashing on the pictograph, then the RAM chips are suspect. If every second RAM chip is failing, check the JU3 (MEM_SIZE) jumper. If multiple RAM are failing, the board is suspect.

Test Sequences

There are five test sequences. Boards equipped with 1.0MB of memory will perform Test Sequences 1, 2 and 3. Minimum mode boards (512K) will perform Test Sequences 1M, 2M, and 3. These test all draw engine operations. Any error within any of these tests would indicate a failure of the Mach 8 coprocessor or a bus timing problem.

NOTE

As not all modes are functional on all monitors, only applicable tests will be indicated.

System Information

This option reports the configuration of the **8514-ULTRA** and the contents of the AUTOEXEC.BAT and CONFIG.SYS files.

Troubleshooting

Because the typical computer system consists of many different parts, difficulties may arise from a combination of items, from software or hardware installation to monitor compatibility.

In Case Of Severe Failure

From the INSTALL program, change “Coprocessor Bus I/O” to 8-bit and re-boot. Remove all unnecessary boards, disable shadow RAM, disable all high RAM, ensure that ROM is running, ensure that the card has been installed using the proper utilities, ensure that the board is seated correctly; put the **8514-ULTRA** in the slot closest to the VGA card; try both 16- and 8-bit slots; try 16-bit slot with the JU4 jumper set to 8-bit.

If The User Has Trouble Installing The ROM

Disable memory managers, disable shadow RAM, disable all high RAM, try various different addresses until INSTALL.EXE accepts the location. The boot ROM only requires 4K of address space.

If The System Won't Boot

Power down, set JU1 to disable EEPROM to a closed position, power up, run INSTALL.EXE; power down; set JU1 to enable EEPROM to an open position; power up; you should see the **8514-ULTRA**.

If The Test Patterns Are OK, But Applications Won't Sync

The wrong monitor type has been selected, change the settings in the INSTALL program.

If The Windows Driver Isn't Installing

The ULTRAGS.DRV driver requires at least 2.0MB of memory with HIMEM.SYS installed. The ULTRAGS driver also requires that the CRYSTAL Fonts have been previously installed and the GSFONTS environment variable be set. Windows will not run correctly in protected

mode if any EMM (Expanded Memory Manager) drivers, other than the Windows EMM Driver, are installed.

NOTE

OEMSETUP.INF is different depending on whether Windows was originally installed using 5¼" or 3½" diskettes. This affects the CRYSTAL Fonts driver installation procedure. The CRYSTAL Fonts driver should be installed using the same diskette type as Windows was originally installed.

If The AutoCAD Driver Isn't Installing

If using a 386, ensure that AutoCAD has been configured for the ADI driver. The protected mode driver requires extended memory.

If the user has a 286, the driver must be loaded as a TSR. The AutoCAD driver relies on the fonts supplied on the **8514-ULTRA** disks. If they are not available, it falls back to the VGA character set. If the VGA character set is not available, AutoCAD will display garbage instead of text.

VGA Text Not Well Defined Or Wrong Color

Change JU8 jumper from Clock Bar to Clock.

Troubleshooting CRYSTAL Fonts

If CRYSTAL Fonts are not appearing on your screen, check the following:

1. **Memory Available**

Make sure that the system has a minimum of 2.0MB of memory available (640K conventional memory and 1.0MB of extended memory). The system will run slowly unless sufficient memory is available.

2. **Software Drivers**

Check the SYSTEM.INI file in your Windows subdirectory that the line "DISPLAY.DRV=ULTRAGS.DRV" is present; the line "DEVICE=HIMEM.SYS" must be in the CONFIG.SYS file. If not, re-install Windows with the CRYSTAL Fonts drivers.

3. **Font Installation**

Check to see if the CRYSTAL Fonts are installed on your hard disk by locating the FONT00XX.GSF files. The environment variable, "SET GSFONTS=C:\GSFONTS" must be in the AUTOEXEC.BAT file. Run INSTALL again, if these are not present.

4. **Printer Driver**
Check the printer driver by selecting the Control Panel in Windows. The printer driver (e.g. PostScript, HP Laserjet III) must support outline fonts or in the case of bit-mapped printer fonts, (e.g. HP Laserjet II) the matching bit-maps must be available on your hard disk, accessible by the software application. Also, the corresponding screen font (that matches the printer font) must be installed, or Windows will default to a bit-map screen font.
5. **Irregular Colors**
Because the CRYSTAL Fonts driver reserves a certain number of colors for the anti-aliasing technique, "palette-aware" programs, such as PowerPoint and CorelDRAW, will use a dithering process to simulate additional colors. A combination of 20 pure colors are used by the driver to create dither patterns. If the dither patterns are not satisfactory, it is recommended that you switch to the ULTRA.DRV driver for full 256 color support.
6. **Incorrect Resolution**
CRYSTAL Fonts are only supported at 1024x768 and 1280x1024 (1.0MB version only) resolution.

Notes About . . .

286 Systems

Certain 286 chip sets may cause the ROM and/or diagnostics to report a severe failure. In this case, power down and set JU4 to 8-bit and try again.

8088 And 8086 Systems

Not supported.

Minimum Mode

The **8514-ULTRA** behaves very differently in the 512K configuration than it does in 1.0MB configuration. If an application uses direct register writes, ensure that it also supports min mode if using a 512K board.

Network Cards And XT Hard Disk Controllers

Many network cards have a default I/O port base address of 2E0. This conflicts with the **8514-ULTRA**. The network card must be reconfigured since the address of the **8514-ULTRA** is not configurable.

AT hard disk controllers have an adapter ROM at default address C800. If the adapter ROM is larger than 2K, it will conflict with the VESA recommended 8514/A address of C880.

VGA Cards

Some VGA cards do not support pass through mode and will conflict with any 8514/A graphics cards.

VGAs With Auto Monitor Detection

All VGAs which have this capability must use the VGA termination plug supplied with the **8514-ULTRA** package.

Windows 3.x

CRYSTAL Fonts will only work with fonts that are supported by your printer.

Using CRYSTAL Fonts with Specific Applications

Aldus PageMaker 3.01 & CRYSTAL Fonts

For the best results with Aldus PageMaker, in the PageMaker Preferences dialog box, set “Greek Test Below...” to 1, and set “Vector Text Above...” to 127. This will allow the CRYSTAL Driver to provide CRYSTAL Fonts for all screen fonts regardless of display size.

Windows & CRYSTAL Fonts

Because of the design of Windows, CRYSTAL Fonts will not scale below 4-point size if a bit-mapped font of the same style resides on your hard disk. Therefore, Times Roman, Helvetica, and Symbol fonts cannot be scaled to show sizes below 4-points as a physical display size on the computer screen.

Customer Support Form

Run the test utilities before calling the Customer Support Department at ATI Technologies Inc. Record the information on the following forms. Have it available when talking to one of our representatives. If you write, please complete both pages of this report and mail it to the address given on the back of this manual or fax it to (416) 756-0720.

Note

Run **INSTALL** and fill in the information from the Diagnostics and System Information program. ATI Technologies Inc. will be unable to process your call without this information.

Diagnostics Test

Circle the problem areas on the appropriate diagram.

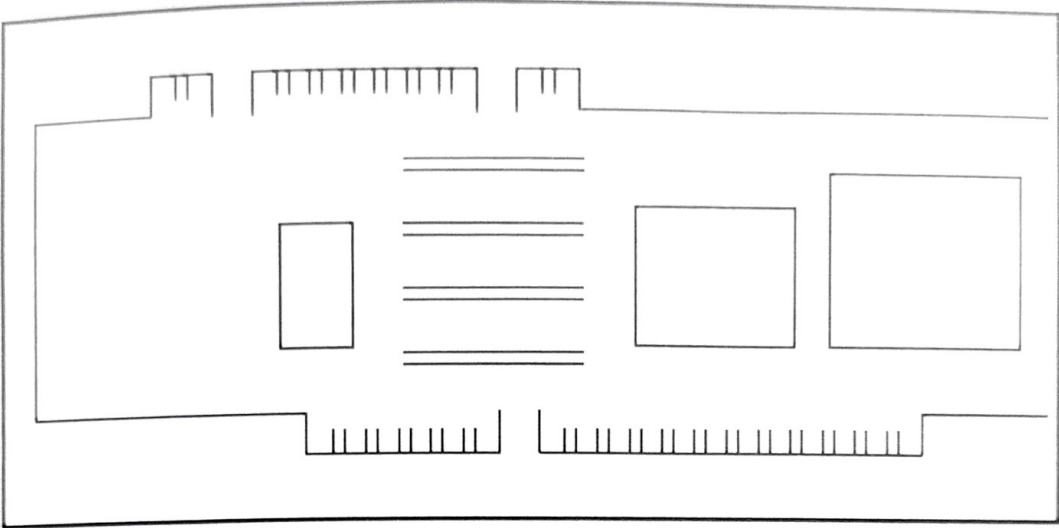

Name: _____

Address: _____

Phone No.: _____ Fax No.: _____

Serial No.: _____

BIOS Version¹: _____ Software Version²: _____

Type & Model of Computer: _____

Type & Model of Monitor: _____

Other Add-on Boards Installed & Versions: _____

Memory Board: _____ Driver Version: _____

Network Software and Version: _____

¹ BIOS Version Number can be displayed by typing: SINFO at the DOS prompt.

² Software Version Number can be found on the diskettes.

EEPROM: Enabled Disabled
Bus Operation: 16-Bit 8-Bit
Bus Type: ISA Micro Channel
VRAM Memory: 1.0MB 512K
ROM Location: _____ Version: _____

System Information

DOS Version: _____

System ROM Date: _____

Contents of AUTOEXEC.BAT: _____

Contents of CONFIG.SYS: _____

List the Necessary Steps to Recreate the Problem:

The ATI Customer Support Department hours:

Monday to Friday: 9:30 a.m. - 5:30 p.m. E.S.T.
Telephone: (416) 756-0711
Facsimile: (416) 756-0720
Bulletin Board Service: (416) 756-4591

Appendix B

Memory Upgrades

To upgrade the memory to 1.0MB, it is required that you use one of the following VRAM chip types; part number: Texas Instruments TMS 44C251-8 or NEC D42274V-8 (256x4 VRAM ZIP Packaging).

Warning

ZIP packaged components are difficult to install. Use extreme care when installing the memory.

Warning

VRAM chips are static sensitive devices. Discharge any static electricity by grounding yourself to the chassis of the PC before handling the chips.

Procedure

Install the RAM chips in the empty sockets on the top of the **8514•ULTRA** board. Ensure that the orientation of the chip, as indicated by a notch at one end, is installed in the same direction as the other RAMs on the card. Inspect each chip carefully for bent pins or reverse insertion.

Appendix C

Custom Monitor Configuration

The INSTALL program has the facility for you to create custom monitor parameters with different resolution/refresh combinations.

Before proceeding further, you should consult your monitor manual to determine what refresh rates and resolution combinations are supported.

Warning

Using the wrong refresh rate (too high a frequency) will damage your monitor. ATI Technologies will not be liable for any damage caused by incorrect settings.

Determining Resolution and Refresh Rates

To create a custom monitor configuration, start the INSTALL program by selecting:

1. "Set Power-up Configuration" <enter>
2. "Monitor Type" <enter>
3. "Custom . . ." <enter>

Select the resolutions supported by your monitor on the following menu.

Select Applicable Resolution and/or Mode
640x480...
800x600...
1024x768...
1280x1024...

Each resolution will be presented with a list of refresh rates, followed by an adjustment screen. Move the highlight bar into the refresh rate of your choice and press <enter> for the adjustment screen.

Adjust 640x480 Mode	Adjust 800x600 Mode
IBM Default 72Hz Non-interlaced	Not Supported 56Hz Non-interlaced 60Hz Non-interlaced 70Hz Non-interlaced 72Hz Non-interlaced 89Hz Interlaced 95Hz Interlaced
Adjust 1024x768 Mode	Adjust 1280x1024 Mode
Not Supported 60Hz Non-interlaced 70Hz Non-interlaced 72Hz Non-interlaced 76Hz Non-interlaced 87Hz Interlaced	Not Supported 87Hz Interlaced

Adjusting Screen Size

After selecting the refresh rate, the following screen will appear:

```

640x480 Screen Adjustment

-- Screen centering operations --
press ← to move screen left
press → to move screen right
press ↑ to move screen up
press ↓ to move screen down

-- Screen sizing operations --
press < to reduce horizontal display
press > to increase horizontal display
press [ to reduce vertical display
press ] to increase vertical display

-- Polarity adjustment operations --
press h to toggle the horizontal sync polarity (+)
press v to toggle the vertical sync polarity (+)
press c to toggle the composite sync

press ESC to return without changes
press RET to accept current screen position

```

Use the following steps to adjust the screen size and position:

1. If the screen is scrambled, select a different refresh rate; the one you have selected is not supported. Press <esc> to return to the “Adjust Mode” menu.

Warning

Do not leave your monitor in this state for extended lengths of time.

2. Press the <h> and/or the <v> key until the box on screen is the optimal size. On full range Multisync type monitors, this option will have no effect.
3. Use the <up>, <down>, <left> and <right> arrow keys to center the screen.
4. If the size of the box requires further adjustments, use the <<> and <>> keys to change the horizontal size and the <[> and <]> keys to change the vertical size. Repeat step 3 to center the box if necessary.
5. Press <enter> to accept the current screen setting or <esc> to return to the “Adjust Mode” menu.
6. You will have to repeat steps 1 through 5 for each resolution. Each resolution/mode can be configured separately, and 800x600, 1024x768 and 1280x1024 resolutions can be disabled if an acceptable refresh rate cannot be obtained.
7. Having adjusted for relevant resolutions/mode, press <Esc> to bring up the prompt “Is your Custom... (Y/N)?”. Press <Y> to accept your new custom configuration. Pressing <N> will allow you to continue making adjustments to the custom monitor configuration.

Newly selected custom configurations can be discarded by pressing <esc> at the “Set Power-Up Configuration” menu and entering <Y> when prompted by “Discard Selected Power-Up...(Y/N)?”.

The information in the EEPROM can be changed or set to factory default through the INSTALL program.

Specifications

System Requirements: IBM AT/386/486, PS/2 or compatible systems.

Bus: ISA 8- or 16-bit, or Micro Channel with video bus.

Video Display Buffer: 512K video memory, upgradeable to 1.0MB.

Sync Signals

Horizontal	Vertical	Resolution
61.0kHz	76Hz	1024x768
58.5 kHz	72Hz	1024x768
56.0 kHz	70Hz	1024x768
54.0 kHz	66Hz	1024x768
50.0 kHz	87Hz	1280x1024 (I)
48.0 kHz	60Hz	1024x768
48.0 kHz	72Hz	800x600
44.2 kHz	70Hz	800x600
37.9 kHz	60Hz	800x600
37.7 kHz	72Hz	640x480
35.5 kHz	87Hz	1024x768 (I)
35.5 kHz	56Hz	800x600
33.8 kHz	95Hz	800x600 (I)
31.5 kHz	89Hz	800x600 (I)
31.5 kHz	60Hz	640x480

(I) - Interlaced

Video Memory Address: A0000 - BFFFF

Video BIOS Address: C0000 - C7FFF

Video Port Address: 2E0 - 2E8

Connectors: Analog Video Connector: 15 pin D shell (Female) IBM standard. VGA Pass Through. 26 pin stake header (cable included) and Micro Channel video bus.

Monitor Compatibility: IBM 8503, 8512, 8513, 8514, 8515 analog monitors, Multisync 2A, 3D, 4DS, 4FG, 5D and other monitors compatible with above standards.

Typefaces: 13 Typefaces (licensed from Bitstream): Courier*, Swiss*, Dutch* (in normal, italic, bold and bold italic weights) and Symbol* styles. CRYSTAL Font Converter available through ATI Customer Support.

Font Generator: Creates anti-aliased fonts using super-sampling technique with 16 colors or shades. Generates 16 versions of each character and dynamically determines best fit. 1024x768 and 1280x1024 support only. Fonts are positionable to 400dpi accuracy.

Drivers Included: Coprocessor Turbo AI (Enhanced 8514/A Adapter Interface), AutoCAD Release 10/11 (Real and Protected mode with Display List Driver), Windows 3.x (1280x1024, 1024x768, 800x600, 640x480), Presentation Manager (1024x768, 800x600, 640x480).

Size: 3.5"(W) x 9.0"(D).

Power: +5V +/-5%, @ 1.3 AMP typical.

Environment: *Ambient Temperature:*
50° to 122° F (10° to 50° C) operation.
32° to 162° F (0° to 70° C) storage.
Relative Humidity:
5% to 90% non-condensing operation.
0% to 95% storage.

Bus Loading: No more than 2 LS TTL load.

MTBF: 120,000 hrs.

Warranty: Five (5) year limited warranty.

Hardware Warranty

ATI Technologies Inc. warrants that the hardware product is in good working condition, according to its specifications at the time of shipment, for a period of five (5) years from the date of purchase to the original purchaser. Should the product, in ATI Technologies Inc.'s opinion, malfunction within the warranty period, ATI Technologies Inc. will repair or replace the product with an equivalent, without charge. Any replaced parts become the property of ATI Technologies Inc. This warranty does not apply to the software component of a product or a product which has been damaged due to accident, misuse, abuse, improper installation, usage not in accordance with product specifications and instructions, natural or personal disaster, or unauthorized alterations, repairs or modifications.

Limitations

This Warranty is valid only if a completed Warranty Card is received within 30 days of purchase of said product.

All warranties for this product, expressed or implied, are limited to five (5) years from the date of purchase and no warranties, expressed or implied, will apply after that period.

No warranties for this product, expressed or implied, shall extend to any person who purchases the product in a used condition.

The liability of ATI Technologies Inc. in respect of any defective product will be limited to the repair or replacement of such product. ATI Technologies Inc. may use new or equivalent to new replacement parts.

ATI Technologies Inc. makes no other representations or warranties as to fitness for purpose, merchantability or otherwise in respect of the product. No other representations, warranties or conditions, shall be implied by statute or otherwise.

In no event shall ATI Technologies Inc. be responsible or liable for any damages arising:

- (a) from the use of the product;
- (b) from the loss of use, revenue or profit of the product; or

- (c) as a result of any event, circumstance, action or abuse beyond the control of ATI Technologies Inc.; whether such damages be direct, indirect, consequential, special or otherwise and whether such damages are incurred by the person to whom this warranty extends or a third party.

Warranty Service

Units requiring repair under warranty require an RMA number. To obtain service under this warranty, first contact:

ATI Technologies Inc.
Customer Support
Telephone: (416) 756-0711
Facsimile: (416) 756-0720

or by writing:

ATI Technologies Inc.
Customer Support
3761 Victoria Park Avenue,
Scarborough, Ontario,
Canada M1W 3S2

and request a Return Material Authorization Number (RMA). This number must be clearly displayed on the unit's external packaging. Units shipped without an RMA number will not be accepted. Include with the unit, proof of purchase (including date of purchase), a note outlining the problem, and the RMA number.

Product should be sent to:

ATI Technologies Inc.
Service Centre
60 Valleybrook Drive
Don Mills, Ontario
Canada M3B 2S9

Important

When shipping your unit, pack securely and ship prepaid and insured. ATI Technologies Inc. will not be held liable for damage or loss to the product in shipment.

Index

- 8514-ULTRA, 1
 - Introduction, 1
 - Features, 1
 - How to Use this Guide, 4

A

- Appendix A, 58
 - Troubleshooting and Diagnostics, 58
 - INSTALL - Test Graphics Adapter, 59
 - Troubleshooting, 61
 - Using CRYSTAL Fonts with Specific Applications, 63
 - Customer Support Form, 64
- Appendix B, 67
 - Memory Upgrades, 67
 - Procedure, 67
- Appendix C, 68
 - Custom Monitor Configuration, 68
 - Determining Resolution and Refresh Rates, 68
 - Adjusting Screen Size, 69
- ATI Device Drivers, 30
 - Main Procedure, 30
 - AutoCAD Procedure, 31
 - Installing the AutoCAD (Real Mode) Driver, 31
 - Using the Display List, 33
 - Presentation Manager for OS/2 Procedure, 35
 - Windows 3.x Procedure, 36
- ATI Turbo Adapter Interface, 39
 - Installing HDILOAD.EXE for DOS, 39
 - How to Load and Unload ATI Turbo AI, 40
 - Installing the ATI Turbo AI for OS/2, 41

C

- Configuring the 8514-ULTRA, 20
 - Getting Started, 20
 - Configuring the 8514-ULTRA, 21
 - Configuration Options, 23
 - Storing the Configuration, 24
 - Uninstall Graphics Adapter, 25
- Contents of the Package, 5
 - 8514-ULTRA Block Diagram, 6
 - Jumper Information, 7
- CRYSTAL Fonts, 27
 - Installation Procedure, 29

H

- Hardware Warranty, 73

M

- Mach 8 Video Controller, 8
- Monitor Selection, 9
 - Automatic Monitor Detection, 9
 - Setting Refresh Rates to Reduce Flicker, 10

I

- Installing on ISA/EISA Computers, 11
- Installing on Micro Channel Computers, 15

S

- Soft Engine/386 for AutoCAD 386, 42
 - Introduction, 42
 - System Requirements, 43
 - Before Installing Soft Engine/386, 43
 - Installation, 44
 - Configuration for AutoCAD, 45
 - Usage with AutoCAD, 49
 - Suggested Button Configurations, 56
 - International Usage, 57
- Software Utilities, 26
 - Procedure, 26
- Specifications, 71

Warranty Registration Card

Customer Support is only available to registered users. Please complete the Warranty Card and return within 30 days of purchase. Proof of purchase including date and place of purchase must accompany product returned for service. A five year limited warranty is provided by ATI Technologies Inc.

CRYSTAL Font Converter

YES!

Please send me the ATI CRYSTAL Font Converter with 22 pre-CRYSTALized Type 1 fonts (for PostScript printers) for \$19.95* (Price without coupon is \$39.95).

To Order

International and U.S. residents please remit in U.S. dollars. Canadian residents please remit in CDN dollars plus 7% GST. Ontario residents please add 8% PST. Outside U.S. and Canada please remit payment by credit card in U.S. funds.

Method of Payment

Check/ VISA Master Card Amex Order

Card Number: _____
 Card Expiration Date: _____
 Name on Card: _____
 Cardholder Signature: _____

* Prices include shipping and handling.

8514-ULTRA Warranty Registration Card

Installed in: ISA/EISA PS/2 512K 1.0MB

Name: _____ Serial No. (see back of the card): _____
 Title: _____ Purchase Date: ____/____/____ Price: _____
 Company: _____ Purchased From: _____
 Address: _____

City _____ State/Province _____ Telephone _____
 Zip/Postal Code _____

City _____ State/Province _____ Telephone _____
 Zip/Postal Code _____

1. I've decided to buy because of:
 Price Driver Support
 High Res. Analog/Digital Monitors
 Quality Dealer Recommendation
 Compatibility Availability
 Brand Name Other: (specify) _____

2. VGA card used: _____

3. Monitor used:
 Brand: _____
 Model: _____
 Mono Color
 VGA Analog
 8514
 Multisync

4. I read:
 PC Magazine
 PC World
 PC Week
 InfoWorld
 Other: (specify) _____

6. I heard about this product from:
 Dealer
 Referral
 Trade Show
 Ad in: (specify) _____

7. Do you use:
 Modem-Mdl.: _____
 Brand: _____
 Fax - Mdl.: _____
 Brand: _____
 Plan to Buy: _____
 Modem Fax



ATI Technologies Inc.
3761 Victoria Park Avenue,
Scarborough, Ontario
CANADA
M1W 3S2

Affix
Stamp
Here

Please fold along solid line

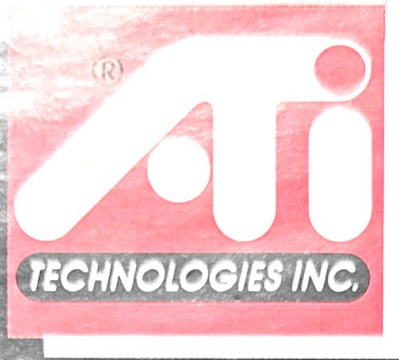

Made in Canada 90 09 01

ATI TECHNOLOGIES INC.
3761 Victoria Park Avenue
Scarborough, Ontario
Canada M1W 3S2
Tel: (416) 756-0718
Fax: (416) 756-0720